

ROBOTICS

Product manual

DressPack IRB 6650S



Trace back information:
Workspace 23D version a12
Checked in 2023-12-06
Skribenta version 5.5.019

Product manual
DressPack IRB 6650S

IRC5, OmniCore

Document ID: 3HAC055424-001

Revision: H

The information in this manual is subject to change without notice and should not be construed as a commitment by ABB. ABB assumes no responsibility for any errors that may appear in this manual.

Except as may be expressly stated anywhere in this manual, nothing herein shall be construed as any kind of guarantee or warranty by ABB for losses, damage to persons or property, fitness for a specific purpose or the like.

In no event shall ABB be liable for incidental or consequential damages arising from use of this manual and products described herein.

This manual and parts thereof must not be reproduced or copied without ABB's written permission.

Keep for future reference.

Additional copies of this manual may be obtained from ABB.

Original instructions.

© Copyright 2004-2023 ABB. All rights reserved.
Specifications subject to change without notice.

Table of contents

Overview of this manual	9
Product documentation	12
Product name principles	14
1 Safety	17
1.1 Safety information	17
1.1.1 Limitation of liability	17
1.1.2 Requirements on personnel	18
1.2 Safety signals and symbols	19
1.2.1 Safety signals in the manual	19
1.2.2 Safety symbols on manipulator labels	20
1.3 Robot stopping functions	26
1.4 Safety during installation and commissioning	27
1.5 Safety during operation	29
1.6 Safety during maintenance and repair	30
1.6.1 Safety during maintenance and repair	30
1.7 Safety during troubleshooting	33
1.8 Safety during decommissioning	34
2 Installation	35
2.1 Introduction	35
2.2 DressPack cable package	36
2.2.1 Overview	36
2.2.2 Fitting the process turning disc	37
2.2.3 Identifying the cable package	40
2.2.4 Installation of IRBDP MH1 LI and IRBDP MH2 LI	42
2.2.4.1 Fitting the attachments of the IRBDP MH1 LI	42
2.2.4.2 Fitting the attachments of IRBDP MH2 LI	45
2.2.4.3 Fitting the cable packages IRBDP MH1 LI and MH2 LI	49
2.2.5 Installation of IRBDP MH3 UE	60
2.2.5.1 Fitting the attachments of the IRBDP MH3 UE	60
2.2.5.2 Fitting the cable package IRBDP MH3 UE	64
2.2.6 Installation of IRBDP MH2 LE and IRBDP SW2 LE	69
2.2.6.1 Fitting the attachments of IRBDP MH2 LE and IRBDP SW2 LE	69
2.2.6.2 Fitting the cable packages IRBDP MH2 LE and IRBDP SW2 LE	74
2.2.7 Installation of IRBDP MH2 UE and IRBDP SW2 UE	83
2.2.7.1 Fitting the attachments of IRBDP MH2 UE and IRBDP SW2 UE	83
2.2.7.2 Fitting the cable packages IRBDP MH2 UE and IRBDP SW2 UE	88
2.2.7.3 Fitting the cable package IRBDP SW2 CE	92
2.2.8 Installation of IRBDP SW5 CE, DressPack basic	101
2.2.8.1 Fitting the attachments of IRBDP SW5 CE (DressPack Basic)	101
2.2.8.2 Fitting the cable package IRBDP SW5 CE (DressPack Basic)	109
2.2.9 Installation of IRBDP SW6 UI, IRBDP MH6 UI and IRBDP SW6 LE, LeanID	115
2.2.9.1 Fitting the attachments of IRBDP SW6 UI and IRBDP MH6 UI, LeanID	115
2.2.9.2 Fitting the attachments of IRBDP SW6 LE, LeanID	121
2.2.9.3 Fitting the cable package IRBDP SW6 LE and IRBDP MH6 UI and SW6 UI, LeanID	127
2.2.10 Installation of IRBDP MH LI	142
2.2.10.1 Fitting the attachments of IRBDP MH LI	142
2.2.10.2 Fitting the cable package IRBDP MH LI	145
2.2.11 Installation of IRBDP MH3 UI	152
2.2.11.1 Fitting the attachments of IRBDP MH3 UI	152
2.2.11.2 Fitting the cable package IRBDP MH3 UI	159
2.2.12 Inspection, DressPack lower arm	165
2.2.13 Inspection, DressPack upper arm	166
2.2.14 Expected lifetime of the integrated DressPack cable package	170

Table of contents

2.3	DressPack adjustments	171
2.3.1	Adjustments of - IRBDP MH2 UE and IRBDP SW2 UE	171
2.3.2	Adjustments of the cable package - IRBDP MH3 UE	175
2.3.3	Adjustment of the cable package - IRBDP SW5 CE (DressPack Basic)	176
2.3.4	Inspection during programming and test-running	178
2.4	DressPack armload parameters	182
2.4.1	DressPack - arm load parameters and LoadId	182
2.5	DressPack floor	188
2.5.1	Installation of DressPack floor	188
2.5.2	Inspection, DressPack floor	191
2.6	Water and air unit	192
2.6.1	Installation of Water and air unit	192
2.6.2	Return water flow control	199
2.6.3	Return water flow switch setting	200
2.6.4	Setting of air pressure switch (only applicable to type S)	202
2.6.5	Setting of electrical proportional valve (option)	204
2.7	Test run after installation, maintenance, or repair	206
3	Maintenance	207
3.1	Introduction	207
3.2	Maintenance schedule and component life	208
3.2.1	Maintenance schedule	208
3.3	Inspection activities	210
3.3.1	Preventive inspection of all cables, DressPack	210
3.3.2	Preventive inspection, DressPack upper arm	212
3.3.3	Preventive inspection of Water and air unit	219
3.4	Cleaning activities	222
3.4.1	Cleaning, DressPack upper arm	222
3.4.2	Cleaning, Water and air unit	225
4	Repair	227
4.1	Introduction	227
4.2	DressPack cable package	228
4.2.1	Repair activities	228
4.2.2	Addition of functional ground (Paramulti)	229
4.2.3	Replacing the cable packages - IRBDP MH1 LI and MH2 LI	230
4.2.4	Replacing the cable packages IRBDP MH2 LE and SW2 LE	238
4.2.5	Replacing the cable packages IRBDP MH2 UE and IRBDP SW2 UE	244
4.2.6	Replacement of cable package IRBDP SW2 CE	247
4.2.7	Replacing the cable package IRBDP MH3 UE	253
4.2.8	Replacing the cable package IRBDP SW5 CE (DressPack Basic)	257
4.2.9	Replacing the cable package IRBDP MH LI	262
4.2.10	Replacing the cable package IRBDP MH3 UI	271
4.2.11	Replacing the cable package IRBDP SW6 LE LeanID	278
4.2.12	Replacing the cable package IRBDP MH6 UI and IRBDP SW6 UI LeanID	288
4.2.13	Replacement of tension arm unit	299
4.2.14	Replacement of damper	302
4.2.15	Replacement of protective sleeves	304
4.2.16	Replacing the protection hose - IRBDP SW6 UI and MH6 UI	307
4.2.17	Repair of process cable package	316
4.2.18	Adjusting tension arm unit	322
4.3	DressPack cable package, general	327
4.3.1	Replacement of hose reinforcement	327
4.3.2	Replacement of slide sleeves	330
4.4	Water and air unit	335
4.4.1	Replacement of Air supply circuit	335
4.4.2	Replacement of Water-in circuit	340
4.4.3	Replacement of Water-return circuit	343
4.4.4	Replacement of Air filter element	346

5	Decommissioning	349
5.1	Environmental information	349
6	Reference information	351
6.1	Introduction	351
6.2	Unit conversion	352
6.3	Screw joints	353
6.4	Weight specifications	356
6.5	Toolkits, DressPack	357
6.6	Lifting accessories and lifting instructions	359
7	Spare parts	361
7.1	Introduction	361
7.2	DressPack cable packages	362
7.2.1	DressPack for lower arm SW - IRBDP SW2 LE	362
7.2.2	DressPack for lower arm MH - IRBDP MH1 LI	363
7.2.3	DressPack for upper arm SW - IRBDP SW2 UE	364
7.2.4	DressPack for Upper arm MH - IRBDP MH2 UE	367
7.2.5	DressPack upper arm MH - IRBDP MH3 UE	370
7.2.6	DressPack for - IRBDP MH2 CE and IRBDP SW2 CE	371
7.2.7	DressPack Basic cable package - IRBDP SW 5 CE	374
7.2.8	DressPack cable package IRBDP SW6 LE LeanID	375
7.2.9	DressPack cable package IRBDP MH3 LI	376
7.2.10	DressPack cable package IRBDP SW6 UI LeanID	377
7.2.11	DressPack cable package IRBDP MH6 UI LeanID	378
7.2.12	DressPack cable package IRBDP MH3 UI	379
7.2.13	Sub cables	380
7.2.14	Wear parts	381
7.2.15	Connection kits	383
7.2.16	7:th axis to base	384
7.2.17	Customer signal/power	385
7.3	DressPack - Water and air unit	386
7.3.1	DressPack - Water and air unit	386
7.4	Mechanical parts	387
8	Circuit diagram	389
8.1	Circuit diagrams	389
	Index	391

This page is intentionally left blank

Overview of this manual

About this manual

This manual contains instructions for:

- mechanical and electrical work for DressPack systems
- maintenance of the DressPack systems
- mechanical and electrical repair of the DressPack systems.

The manual also contains reference information for all procedures detailed in the manual.

Usage

This manual should be used during:

- installation of the DressPack system
- maintenance of the DressPack system
- repair work of the DressPack system.

Who should read this manual?

This manual is intended for:

- installation personnel
- maintenance personnel
- repair personnel.

Prerequisites

A maintenance/repair/installation craftsman working with an ABB Robot must:

- be trained by ABB and have the required knowledge of mechanical and electrical installation/repair/maintenance work.

Organization of chapters

The manual is organized in the following chapters:

Chapter	Contents
Safety	Safety information that must be read through before performing any installation or service work on the robot. Contains general safety aspects as well as more specific information on how to avoid personal injuries and damage to the product.
Installation	Descriptions of mechanical installation and electrical connections.
Maintenance	Descriptions of all required preventive maintenance procedures including intervals.
Repair	Descriptions of all recommended repair procedures.
Reference information	Useful information when performing installation, maintenance or repair work. Includes lists of necessary tools, additional documents, safety standards etc.
Spare parts	Complete spare part list and list of robot components, shown in exploded views.
Circuit diagram	References to the circuit diagrams.

Continues on next page

Overview of this manual

Continued

References

General

Document name	Document ID
<i>Product manual - IRB 6650S</i>	<i>3HAC020993-001</i>
<i>Product manual - IRB 7600</i>	<i>3HAC022033-001</i>
<i>Safety manual for robot - Manipulator and IRC5 or OmniCore controllerⁱ</i>	<i>3HAC031045-001</i>
<i>Circuit diagram - DressPack 6650S/7600</i>	<i>3HAC026208-001</i>
<i>Circuit diagram - DressPack 6650S/7600</i>	<i>3HAC026209-001</i>

ⁱ This manual contains all safety instructions from the product manuals for the manipulators and the controllers.

OmniCore robots

Document name	Document ID
<i>Product specification - IRB 6650S</i>	<i>3HAC081956-001</i>
<i>Product manual - OmniCore V250XT Type B</i>	<i>3HAC087112-001</i>
<i>Product manual - OmniCore V400XT</i>	<i>3HAC081697-001</i>
<i>Operating manual - OmniCore</i>	<i>3HAC065036-001</i>
<i>Technical reference manual - System parameters</i>	<i>3HAC065041-001</i>

IRC5 robots

Document name	Document ID
<i>Product specification - IRB 6650S</i>	<i>3HAC030822-001</i>
<i>Product specification - IRB 7600</i>	<i>Document.ID-1</i>
<i>Product manual - IRC5</i> IRC5 with main computer DSQC 639.	<i>3HAC021313-001</i>
<i>Product manual - IRC5</i> IRC5 with main computer DSQC1000.	<i>3HAC047136-001</i>
<i>Operating manual - IRC5 with FlexPendant</i>	<i>3HAC050941-001</i>
<i>Technical reference manual - System parameters</i>	<i>3HAC050948-001</i>

Revisions

Revision	Description
-	First edition.
A	Published in release R16.2. The following updates are done in this revision: <ul style="list-style-type: none">Information about Spot welding cabinet removed. <i>Product manual - Spot welding cabinet IRC5 (3HAC058524-001)</i> describes the Spot welding cabinet.
B	Published in release R17.2. The following updates are done in this revision: <ul style="list-style-type: none">Updated list of applicable standards.Installation of Water and air unit updated.

Continues on next page

Revision	Description
C	Published in release R18.1. The following updates are made in this revision: <ul style="list-style-type: none"> • Clarified procedure for tension adjustment, see Adjusting tension arm unit on page 322. • Safety section restructured.
D	Published in release R19C. The following updates are made in this revision: <ul style="list-style-type: none"> • Information about functional ground added throughout the manual. • Updated spare part numbers for Paramulti cable packages.
E	Published in release 21C. The following updates are made in this revision: <ul style="list-style-type: none"> • Caution regarding handling connectors with care included in Installation and Repair chapters.
F	Published in release 22C. The following updates are made in this revision: <ul style="list-style-type: none"> • Added information for the OmniCore robot controller. • Added more specific information about what torque tool to use for M12 Ethernet/PROFINET connectors throughout the manual.
G	Published in release 22D. The following updates are made in this revision: <ul style="list-style-type: none"> • Information about required space between Process cable support and calibration pin on axis 6 added.
H	Published in release 23D. The following updates are made in this revision: <ul style="list-style-type: none"> • Added more specific information about materials, tightening torque and lubrication for couplings.

Product documentation

Categories for user documentation from ABB Robotics

The user documentation from ABB Robotics is divided into a number of categories. This listing is based on the type of information in the documents, regardless of whether the products are standard or optional.



Tip

All documents can be found via myABB Business Portal, www.abb.com/myABB.

Product manuals

Manipulators, controllers, DressPack, and most other hardware is delivered with a **Product manual** that generally contains:

- Safety information.
- Installation and commissioning (descriptions of mechanical installation or electrical connections).
- Maintenance (descriptions of all required preventive maintenance procedures including intervals and expected life time of parts).
- Repair (descriptions of all recommended repair procedures including spare parts).
- Calibration.
- Troubleshooting.
- Decommissioning.
- Reference information (safety standards, unit conversions, screw joints, lists of tools).
- Spare parts list with corresponding figures (or references to separate spare parts lists).
- References to circuit diagrams.

Technical reference manuals

The technical reference manuals describe reference information for robotics products, for example lubrication, the RAPID language, and system parameters.

Application manuals

Specific applications (for example software or hardware options) are described in **Application manuals**. An application manual can describe one or several applications.

An application manual generally contains information about:

- The purpose of the application (what it does and when it is useful).
- What is included (for example cables, I/O boards, RAPID instructions, system parameters, software).
- How to install included or required hardware.
- How to use the application.

Continues on next page

- Examples of how to use the application.

Operating manuals

The operating manuals describe hands-on handling of the products. The manuals are aimed at those having first-hand operational contact with the product, that is production cell operators, programmers, and troubleshooters.

Product name principles

General

The different robots have a wide range of options. In many cases the option name gives a good explanation of its content. In some cases there is a need to add more information in the product name in order to clearly show a certain variant and to avoid misunderstandings. Hence a complementary naming standard is used.

The family name of the options is DressPack (that is customer cables and hoses from the controller to the robot's axis 6, divided in different sections).

DressPack parts

DressPack parts that are assembled on the robot are called:

- IRBDP (IRB DressPack)

Main application

The DressPack has been prepared for two main applications:

Product name	Application
MH	Material handling
SW	Spot welding

Generations

The different generations of a DressPack is indicated with a generation number. The number indicates the different design of each generation. (Some generations might not be available since it has been phased out).

- 1, 2, 3 etc

Sections

The DressPack on the robot is supplied in different sections:

Product name	Section
L	Lower DressPack section
U	Upper DressPack section
C	Continuous DressPack (DressPack without an intermediate connection point)

Routing

The DressPack can be routed in different ways:

Product name	Routing
I	Integrated DressPack The main parts are integrated within the robot structure.
E	External DressPack The main parts are routed outside, on the robot structure.

Continues on next page

Examples

- **IRBDP MH 3 UE** = IRB DressPack / Material handling application / Generation 3 / Upper arm DressPack section / External routing
- **IRBDP SW 4 UI** = IRB DressPack / Spot welding application / Generation 4 / Upper arm DressPack section / Internal routing
- **IRBDP SW 2 LE** = IRB DressPack / Spot welding application / Generation 2 / Lower arm DressPack section / External routing
- **IRBDP SW 2 CE** = IRB DressPack / Spot welding application / Generation 2 / Continuous DressPack section / External routing

This page is intentionally left blank

1 Safety

1.1 Safety information

1.1.1 Limitation of liability

Limitation of liability

Any information given in this manual regarding safety must not be construed as a warranty by ABB that the industrial robot will not cause injury or damage even if all safety instructions are complied with.

The information does not cover how to design, install and operate a robot system, nor does it cover all peripheral equipment that can influence the safety of the robot system.

In particular, liability cannot be accepted if injury or damage has been caused for any of the following reasons:

- Use of the robot in other ways than intended.
- Incorrect operation or maintenance.
- Operation of the robot when the safety devices are defective, not in their intended location or in any other way not working.
- When instructions for operation and maintenance are not followed as intended.
- Non-authorized design modifications of the robot.
- Repairs on the robot and its spare parts carried out by in-experienced or non-qualified personnel.
- Foreign objects.
- Force majeure.

Spare parts and equipment

ABB supplies original spare parts and equipment which have been tested and approved for their intended use. The installation and/or use of non-original spare parts and equipment can negatively affect the safety, function, performance, and structural properties of the robot. ABB is not liable for damages caused by the use of non-original spare parts and equipment.

1 Safety

1.1.2 Requirements on personnel

1.1.2 Requirements on personnel

General

Only personnel with appropriate training are allowed to install, maintain, service, repair, and use the robot. This includes electrical, mechanical, hydraulics, pneumatics, and other hazards identified in the risk assessment.

Persons who are under the influence of alcohol, drugs or any other intoxicating substances are not allowed to install, maintain, service, repair, or use the robot.

The plant liable must make sure that the personnel is trained on the robot, and on responding to emergency or abnormal situations.

Personal protective equipment

Use personal protective equipment, as stated in the instructions.

1.2 Safety signals and symbols

1.2.1 Safety signals in the manual







Introduction to safety signals

This section specifies all safety signals used in the user manuals. Each signal consists of:

- A caption specifying the hazard level (DANGER, WARNING, or CAUTION) and the type of hazard.
- Instruction about how to reduce the hazard to an acceptable level.
- A brief description of remaining hazards, if not adequately reduced.

Hazard levels

The table below defines the captions specifying the hazard levels used throughout this manual.

Symbol	Designation	Significance
	DANGER	Signal word used to indicate an imminently hazardous situation which, if not avoided, will result in serious injury.
	WARNING	Signal word used to indicate a potentially hazardous situation which, if not avoided, could result in serious injury.
	ELECTRICAL SHOCK	Signal word used to indicate a potentially hazardous situation related to electrical hazards which, if not avoided, could result in serious injury.
	CAUTION	Signal word used to indicate a potentially hazardous situation which, if not avoided, could result in slight injury.
	NOTE	Signal word used to indicate important facts and conditions.
	TIP	Signal word used to indicate where to find additional information or how to do an operation in an easier way.

1 Safety

1.2.2 Safety symbols on manipulator labels

1.2.2 Safety symbols on manipulator labels

Introduction to symbols

This section describes safety symbols used on labels (stickers) on the manipulator. Symbols are used in combinations on the labels, describing each specific warning. The descriptions in this section are generic, the labels can contain additional information such as values.



Note

The symbols on the labels on the product must be observed. Additional symbols added by the integrator must also be observed.



Types of symbols

Both the manipulator and the controller are marked with symbols, containing important information about the product. This is important for all personnel handling the robot, for example during installation, service, or operation.



The safety labels are language independent, they only use graphics. See [Symbols on safety labels on page 20](#).

The information labels can contain information in text.

Symbols on safety labels

Symbol	Description
 xx0900000812	Warning! Warns that an accident <i>may</i> occur if the instructions are not followed that can lead to serious injury, possibly fatal, and/or great damage to the product. It applies to warnings that apply to danger with, for example, contact with high voltage electrical units, explosion or fire risk, risk of poisonous gases, risk of crushing, impact, fall from height, etc.
 xx0900000811	Caution! Warns that an accident may occur if the instructions are not followed that can result in injury and/or damage to the product. It also applies to warnings of risks that include burns, eye injury, skin injury, hearing damage, crushing or slipping, tripping, impact, fall from height, etc. Furthermore, it applies to warnings that include function requirements when fitting and removing equipment where there is a risk of damaging the product or causing a breakdown.
 xx0900000839	Prohibition Used in combinations with other symbols.

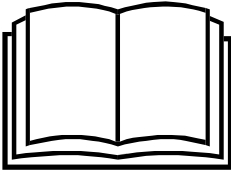
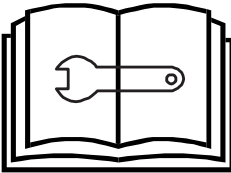
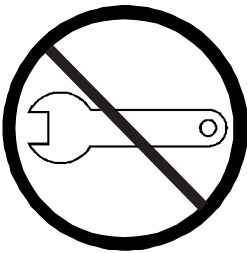
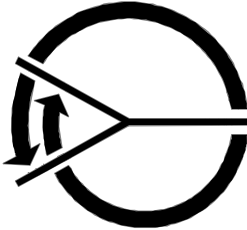

Continues on next page

Symbol	Description
 <p>xx0900000813</p>	<p>See user documentation Read user documentation for details. Which manual to read is defined by the symbol:</p> <ul style="list-style-type: none"> • No text: <i>Product manual</i>. • EPS: <i>Application manual - Electronic Position Switches</i>.
 <p>xx0900000816</p>	<p>Before disassembly, see product manual</p>
 <p>xx0900000815</p>	<p>Do not disassemble Disassembling this part can cause injury.</p>
 <p>xx0900000814</p>	<p>Extended rotation This axis has extended rotation (working area) compared to standard.</p>
 <p>xx0900000808</p>	<p>Brake release Pressing this button will release the brakes. This means that the robot arm can fall down.</p>

1 Safety

1.2.2 Safety symbols on manipulator labels

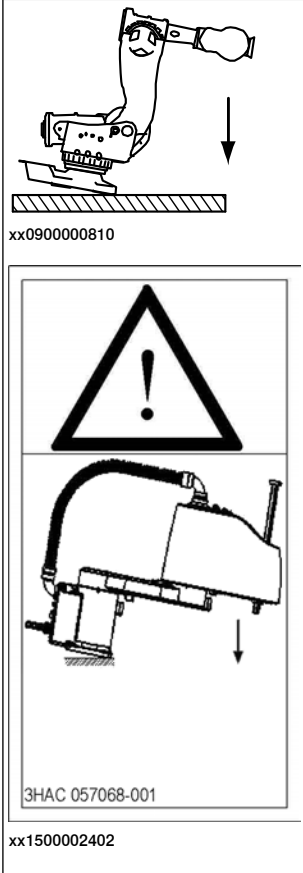
Continued

Symbol	Description
 <p>xx0900000810</p> <p>3HAC 057068-001</p> <p>xx1500002402</p>	<p>Tip risk when loosening bolts The robot can tip over if the bolts are not securely fastened.</p>
 <p>xx0900000817</p>	<p>Crush Risk of crush injuries.</p>



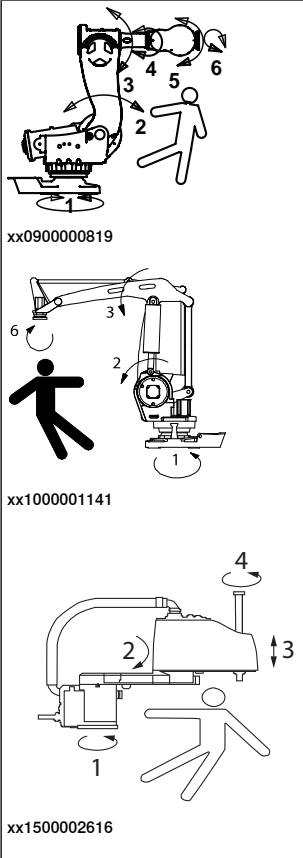



Continues on next page

Symbol	Description
 <p>xx0900000818</p> <p>xx1300001087</p>	<p>Heat Risk of heat that can cause burns. (Both signs are used)</p>
 <p>xx0900000819</p> <p>xx1000001141</p> <p>xx1500002616</p>	<p>Moving robot The robot can move unexpectedly.</p>

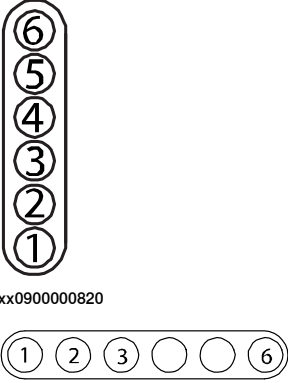

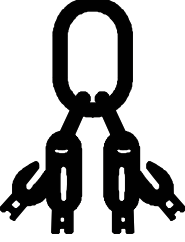

1 Safety

1.2.2 Safety symbols on manipulator labels

Continued

Symbol	Description
 <p>xx0900000820</p> <p>xx1000001140</p>	<p>Brake release buttons</p>
 <p>xx0900000821</p>	<p>Lifting bolt</p>
 <p>xx1000001242</p>	<p>Adjustable chain sling with shortener</p>
 <p>xx0900000822</p>	<p>Lifting of robot</p>
 <p>xx0900000823</p>	<p>Oil Can be used in combination with prohibition if oil is not allowed.</p>
 <p>xx0900000824</p>	<p>Mechanical stop</p>

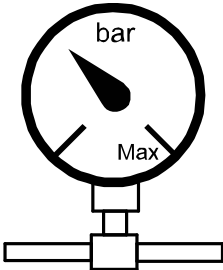
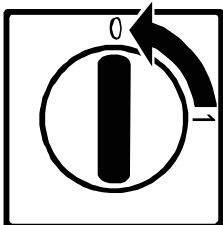
Continues on next page

Symbol	Description
 <p>xx1000001144</p>	<p>No mechanical stop</p>
 <p>xx0900000825</p>	<p>Stored energy Warns that this part contains stored energy. Used in combination with <i>Do not disassemble</i> symbol.</p>
 <p>xx0900000826</p>	<p>Pressure Warns that this part is pressurized. Usually contains additional text with the pressure level.</p>
 <p>xx0900000827</p>	<p>Shut off with handle Use the power switch on the controller.</p>
 <p>xx1400002648</p>	<p>Do not step Warns that stepping on these parts can cause damage to the parts.</p>

1 Safety

1.3 Robot stopping functions

1.3 Robot stopping functions

Protective stop and emergency stop

The protective stops and emergency stops are described in the product manual for the controller.

For more information see:

- *Product manual - OmniCore V250XT Type B*
- *Product manual - OmniCore V400XT*
- *Product manual - IRC5*

1.4 Safety during installation and commissioning

National or regional regulations

The integrator of the robot system is responsible for the safety of the robot system.

The integrator is responsible that the robot system is designed and installed in accordance with the safety requirements set forth in the applicable national and regional standards and regulations.

The integrator of the robot system is required to perform a risk assessment.

Layout

The robot integrated to a robot system shall be designed to allow safe access to all spaces during installation, operation, maintenance, and repair.

If robot movement can be initiated from an external control panel then an emergency stop must also be available.

Consider exposure to hazards, such as slipping, tripping, and falling.

Hazards due to the working position and posture for a person working with or near the robot shall be considered.

Hazards due to noise emission from the robot needs to be considered.

Consider hazards from other equipment in the robot system, for example, that guards remain active until identified hazards are reduced to an acceptable level.

Allergenic material

See [Environmental information on page 349](#) for specification of allergenic materials in the product, if any.

Securing the robot to the foundation

The robot must be properly fixed to its foundation/support, as described in the respective product manual.

When the robot is installed at a height, hanging, or other than mounted directly on the floor, there will be additional hazards.

Using lifting accessories and other external equipment

Ensure that all equipment used during installation, service and all handling of the robot are in correct condition for the intended use.

Electrical safety

Incoming mains must be installed to fulfill national regulations.

The power supply wiring to the robot must be sufficiently fused and if necessary, it must be possible to disconnect it manually from the mains power.

The power to the robot must be turned off with the main switch and the mains power disconnected when performing work inside the controller cabinet. Lock and tag shall be considered.

Harnesses between controller and manipulator shall be fixed and protected to avoid tripping and wear.

Continues on next page

1 Safety

1.4 Safety during installation and commissioning

Continued

Wherever possible, power on/off or rebooting the robot controller shall be performed with all persons outside the safeguarded space.



Note

Use a CARBON DIOXIDE (CO₂) extinguisher in the event of a fire in the robot.

Safety devices

The integrator is responsible for that the safety devices necessary to protect people working with the robot system are designed and installed correctly.

When integrating the robot with external devices to a robot system:

- The integrator of the robot system must ensure that emergency stop functions are interlocked in accordance with applicable standards.
- The integrator of the robot system must ensure that safety functions are interlocked in accordance with applicable standards.

Other hazards

The risk assessment should also consider other hazards arising from the application, such as, but not limited to:

- Water
- Compressed air
- Hydraulics

End-effector hazards require particular attention for applications which involve close human collaboration with the robot.

Pneumatic or hydraulic related hazards



Note

The pressure in the complete pneumatic or hydraulic systems must be released before service and maintenance.

All components in the robot system that remain pressurized after switching off the power to the robot must be marked with clearly visible drain facilities and a warning sign that indicates the hazard of stored energy.

Loss of pressure in the robot system may cause parts or objects to drop.

Dump valves should be used in case of emergency.

Shot bolts should be used to prevent tools, etc., from falling due to gravity.

All pipes, hoses, and connections have to be inspected regularly for leaks and damage. Damage must be repaired immediately.

Verify the safety functions

Before the robot system is put into operation, verify that the safety functions are working as intended and that any remaining hazards identified in the risk assessment are mitigated to an acceptable level.

1.5 Safety during operation

Automatic operation

Verify the application in the operating mode manual reduced speed, before changing mode to automatic and initiating automatic operation.

Unexpected movement of robot arm



WARNING

Hazards due to the use of brake release devices and/or gravity beneath the manipulator shall be considered.

1 Safety

1.6.1 Safety during maintenance and repair

1.6 Safety during maintenance and repair

1.6.1 Safety during maintenance and repair

General

Corrective maintenance must only be carried out by personnel trained on the robot. Maintenance or repair must be done with all electrical, pneumatic, and hydraulic power switched off, that is, no remaining hazards.

Hazards due to stored mechanical energy in the manipulator for the purpose of counterbalancing axes must be considered before maintenance or repair.

Never use the robot as a ladder, which means, do not climb on the controller, manipulator, including motors, or other parts. There are hazards of slipping and falling. The robot might be damaged.

Make sure that there are no tools, loose screws, turnings, or other unexpected parts remaining after maintenance or repair work.

When the work is completed, verify that the safety functions are working as intended.

Hot surfaces

Surfaces can be hot after running the robot, and touching these may result in burns. Allow the surfaces to cool down before maintenance or repair.

Allergic reaction

Warning	Description	Elimination/Action
 Allergic reaction	When working with lubricants there is a risk of an allergic reaction.	Make sure that protective gear like goggles and gloves are always worn.

Gearbox lubricants (oil or grease)

When handling oil, grease, or other chemical substances the safety information of the respective manufacturer must be observed.









Note

Take special care when handling hot lubricants.

Warning	Description	Elimination/Action
 Hot oil or grease	Changing and draining gearbox oil or grease may require handling hot lubricant heated up to 90 °C.	Make sure that protective gear like goggles and gloves are always worn during this activity.

Continues on next page

Warning	Description	Elimination/Action
 Allergic reaction	When working with lubricants there is a risk of an allergic reaction.	Make sure that protective gear like goggles and gloves are always worn.
 Possible pressure build-up in gearbox	When opening the oil or grease plug, there may be pressure present in the gearbox, causing lubricant to spray from the opening.	Open the plug carefully and keep away from the opening. Do not overfill the gearbox when filling.
 Do not overfill	Overfilling of gearbox lubricant can lead to internal over-pressure inside the gearbox which in turn may: <ul style="list-style-type: none"> • damage seals and gaskets • completely press out seals and gaskets • prevent the robot from moving freely. 	Make sure not to overfill the gearbox when filling it with oil or grease. After filling, verify that the level is correct.
 Do not mix types of oil	Mixing types of oil may cause severe damage to the gearbox.	When filling gearbox oil, do not mix different types of oil unless specified in the instructions. Always use the type of oil specified for the product.
 Oil residues	Oil residues might be present in a drained gearbox and spilled when separating a motor and gearbox during repair.	Make sure that protective gear like goggles/protective visor, gloves and arm protection are always worn during this activity. Put oil absorbent cloth or paper at appropriate locations to catch any oil residues.
 Heat up the oil	Warm oil drains quicker than cold oil.	Run the robot before changing the gearbox oil, if possible.
 Specified amount depends on drained volume	The specified amount of oil or grease is based on the total volume of the gearbox. When changing the lubricant, the amount refilled may differ from the specified amount, depending on how much has previously been drained from the gearbox.	After filling, verify that the level is correct.

Continues on next page

1 Safety

1.6.1 Safety during maintenance and repair

Continued

Warning	Description	Elimination/Action
 Contaminated oil in gearboxes	For lifetime reasons always drain as much oil as possible from the gearbox. The magnetic oil plugs will gather residual metal chips.	

Hazards related to batteries

Under rated conditions, the electrode materials and liquid electrolyte in the batteries are sealed and not exposed to the outside.

There is a hazard in case of abuse (mechanical, thermal, electrical) which leads to the activation of safety valves and/or the rupture of the battery container. As a result under certain circumstances, electrolyte leakage, electrode materials reaction with moisture/water or battery vent/explosion/fire may follow.

Do not short circuit, recharge, puncture, incinerate, crush, immerse, force discharge or expose to temperatures above the declared operating temperature range of the product. Risk of fire or explosion.

See safety instructions for the batteries in *Material/product safety data sheet - Battery pack (3HAC043118-001)*.

Related information

See also the safety information related to installation and operation.

1.7 Safety during troubleshooting

General

When troubleshooting requires work with power switched on, special considerations must be taken:

- Safety circuits might be muted or disconnected.
- Electrical parts must be considered as *live*.
- The manipulator can move unexpectedly at any time.



DANGER

Troubleshooting on the controller while powered on must be performed by personnel trained by ABB or by ABB field engineers.

A risk assessment must be done to address both robot and robot system specific hazards.

Related information

See also the safety information related to installation, operation, maintenance, and repair.

1 Safety

1.8 Safety during decommissioning

1.8 Safety during decommissioning

General

See section [Decommissioning on page 349](#).

If the robot is decommissioned for storage, take extra precaution to reset safety devices to delivery status.

2 Installation

2.1 Introduction

General

This chapter presents general information, complementing the more specific information in the following chapters.

Sections

The installation chapter is divided in the following sections:

- Fitting DressPack cable package attachments
- Fitting DressPack cable packages
- DressPack floor cable
- Water and air unit

2 Installation

2.2.1 Overview

2.2 DressPack cable package

2.2.1 Overview

General

Installing, programming and operating the ABB DressPack product program may be a complex task as each application instance is very specific. The product is designed to fit a wide variety of applications, and must be adapted to each in order to maximize life and function.

The generic installation procedure is described below.



CAUTION

The cabling is sensitive to mechanical damage. Handle it with care to avoid damage to the cabling or the connector, avoid any kind of tilt or skew.

Limitations of robot movements

When using DressPack options on the upper arm, the robot movements will be limited.

- In bending backwards positions there are limitations due to interference with the robot itself or with the Water and Air unit (if such is mounted).

Effects on armload and performance



Note

The extra weight of the DressPack products will affect the armload data and the performance of the robot. The effect differs depending on which type of DressPack product. See [DressPack - arm load parameters and LoadId](#).

2.2.2 Fitting the process turning disc

Location of the IRBDP SW6 process turning disc

The process turning disc is located in the front of the wrist housing as shown in the figure.

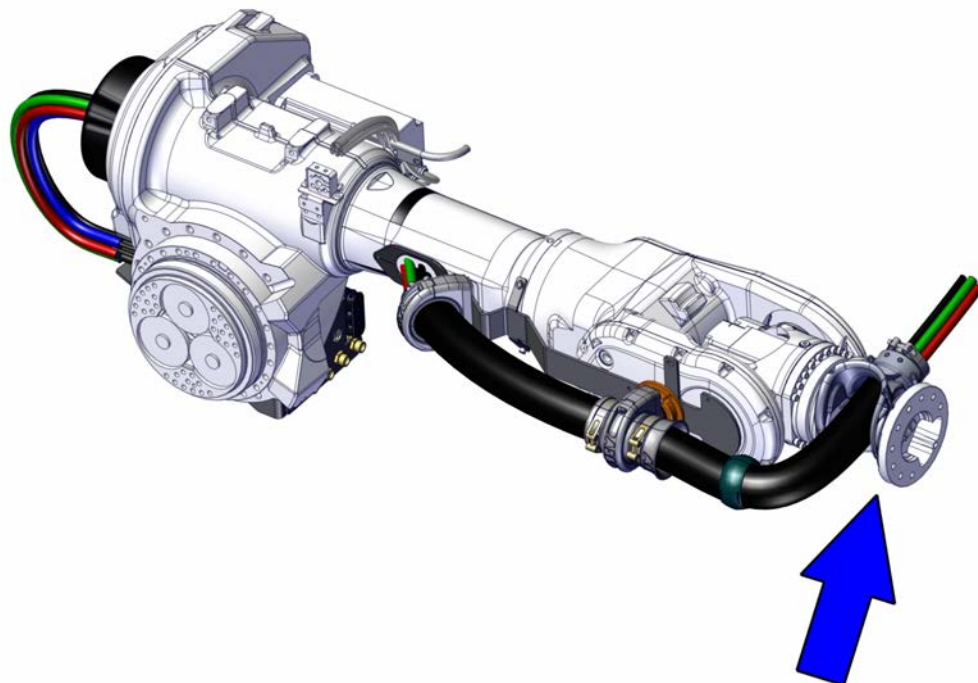

xx150000846

Required tools and equipment

Equipment, etc.	Article number	Note
Standard toolkit	-	Content is defined in section Standard toolkit on page 357 .

Fitting the IRBDP SW6 process turning disc

Use this procedure to fit the process turning disc.

Screw joint for refitting process turning disc

Variant	Screw dimension	Number of screws	Number of washers	Tightening torque
3HAB3409-66	M12x35	12 pcs	12 pcs	120 Nm

Fitting the IRBDP SW6 process turning disc

	Action	Note
1	Wipe clean the contacts surfaces.	

Continues on next page

2 Installation

2.2.2 Fitting the process turning disc

Continued

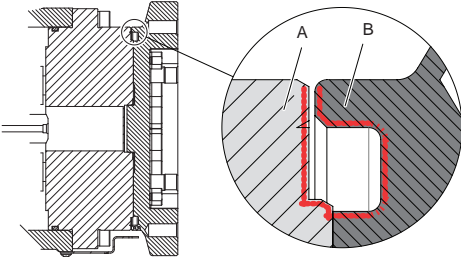
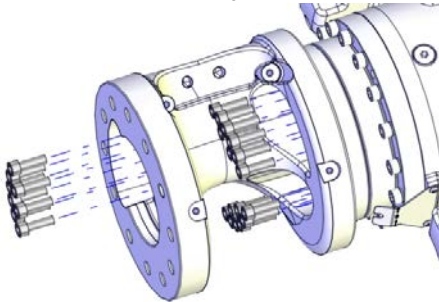
	Action	Note
2	<p>Foundry Plus: Apply Mercasol on the surfaces on the process turning disc and axis-6 gearbox as shown in the figure.</p>	 <p>xx140000385</p> <p>The figure show standard turning disc. Surfaces to apply Mercasol on are the same with process turning disc.</p>
3	<p>Secure the process turning disc with its attachment screws and washers.</p>	<p>Tightening torque: 120 Nm. Screw dimension: M12x35, Steel 12.9 Gleitmo 603 (12 pcs) Washers: 13x19x1 (12 pcs)</p>  <p>xx1400001392</p>

Removing the process turning disc

Use these procedures to remove the process turning disc.

Preparations before removing the process turning disc

	Action	Note
1	<p>Run the robot to the most comfortable position for the removal of the process turning disc.</p>	
2	<p> DANGER</p> <p>Turn off all:</p> <ul style="list-style-type: none"> • electric power supply • water pressure supply • air pressure supply <p>to the robot, before entering the robot working area.</p>	
3	<p>Remove any equipment fitted to the process turning disc.</p>	

Continues on next page

	Action	Note
4	<p>Allow time for cooling down oil in axis 6, if the robot has been in operation.</p> <p> WARNING</p> <p>The oil inside axis 6 wrist is hot if the robot has been in operation. It may reach a temperature of 90°C. Risk of burns, use protective gloves and goggles.</p>	

Removing the process turning disc

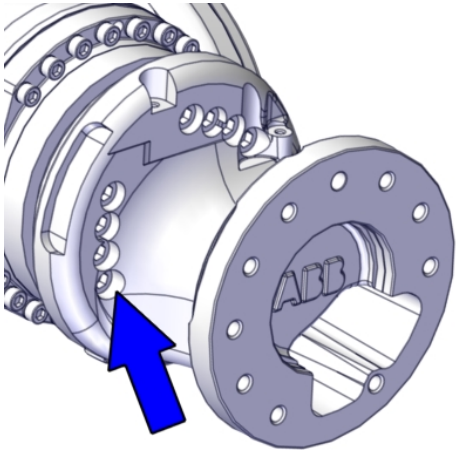
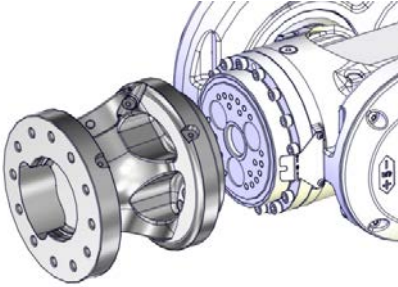
	Action	Note
1	<p>Remove the 12 screws and washers that secure the process turning disc.</p>	 <p>xx150000867</p>
2	<p>Remove the process turning disc.</p>	 <p>xx1400001393</p>

2 Installation

2.2.3 Identifying the cable package

2.2.3 Identifying the cable package

Identify the cabling

The installation procedures are splitted into two sections; one is fitting of the attachments and the other one is fitting of the cable package.

To be able to identify the attachments and the cable package, see the following table. The cable packages are marked with article number at delivery.

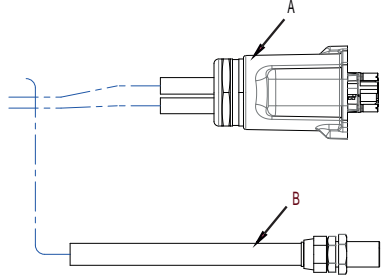
Description	Article number	Note				
IRBDP MH1 LI	<i>DressPack for lower arm MH - IRBDP MH1 LI on page 363</i>	<i>Fitting the attachments of the IRBDP MH1 LI on page 42</i>				
IRBDP MH2 LI		<i>Fitting the attachments of IRBDP MH2 LI on page 45</i>				
IRBDP MH2 LE		<i>Fitting the attachments of IRBDP MH2 LE and IRBDP SW2 LE on page 69</i>				
IRBDP MH2 CE	<i>DressPack for - IRBDP MH2 CE and IRBDP SW2 CE on page 371</i>	<i>Fitting the cable package IRBDP SW2 CE on page 92</i>				
IRBDP SW2 CE	<i>DressPack for - IRBDP MH2 CE and IRBDP SW2 CE on page 371</i>	<i>Fitting the cable package IRBDP SW2 CE on page 92</i>				
IRBDP SW2 LE	<i>DressPack for lower arm SW - IRBDP SW2 LE on page 362</i>	<i>Fitting the attachments of IRBDP MH2 LE and IRBDP SW2 LE on page 69</i>				
IRBDP MH2 UE	<i>DressPack for Upper arm MH - IRBDP MH2 UE on page 367</i>	<i>Fitting the attachments of IRBDP MH2 UE and IRBDP SW2 UE on page 83</i>				
IRBDP SW2 UE	<i>DressPack for upper arm SW - IRBDP SW2 UE on page 364</i>	<i>Fitting the attachments of IRBDP MH2 UE and IRBDP SW2 UE on page 83</i>				
IRBDP MH3 UE	<i>DressPack upper arm MH - IRBDP MH3 UE on page 370</i>	<p><i>Fitting the attachments of the IRBDP MH3 UE on page 60</i></p>  <p>xx1500001653</p> <table border="1"> <tbody> <tr> <td>A</td> <td>R2.CP/CS</td> </tr> <tr> <td>B</td> <td>R2.PROC1</td> </tr> </tbody> </table>	A	R2.CP/CS	B	R2.PROC1
A	R2.CP/CS					
B	R2.PROC1					

Continues on next page

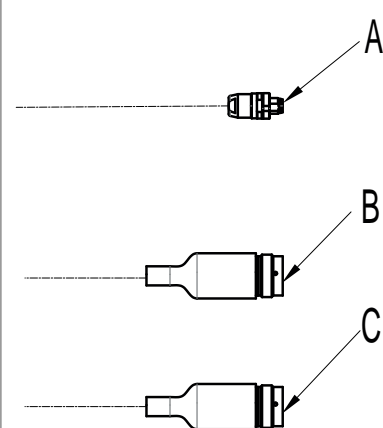
Description	Article number	Note						
IRBDP MH3 UI	<i>DressPack cable package IRBDP MH3 UI on page 379</i>	<p><i>Fitting the attachments of IRBDP MH3 UI on page 152</i></p>  <p>xx1500001652</p> <table border="1"> <tr> <td>A</td> <td>R3 Ethernet</td> </tr> <tr> <td>B</td> <td>R3.CBUS</td> </tr> <tr> <td>C</td> <td>R3.CPS</td> </tr> </table>	A	R3 Ethernet	B	R3.CBUS	C	R3.CPS
A	R3 Ethernet							
B	R3.CBUS							
C	R3.CPS							
IRBDP SW5 CE	<i>DressPack Basic cable package - IRBDP SW 5 CE on page 374</i>	<i>Fitting the attachments of IRBDP SW5 CE (DressPack Basic) on page 101</i>						
IRBDP MH LI	<i>DressPack cable package IRBDP MH3 LI on page 376</i>	<i>Fitting the attachments of IRBDP MH LI on page 142</i>						
IRBDP SW6 LE	<i>DressPack cable package IRBDP SW6 LE LeanID on page 375</i>	<i>Fitting the attachments of IRBDP SW6 LE, LeanID on page 121</i>						
IRBDP MH6 UI	<i>DressPack cable package IRBDP MH6 UI LeanID on page 378</i>	<i>Fitting the attachments of IRBDP SW6 UI and IRBDP MH6 UI, LeanID on page 115</i>						
IRBDP SW6 UI (LeanID)	<i>DressPack cable package IRBDP SW6 UI LeanID on page 377</i>	<i>Fitting the attachments of IRBDP SW6 UI and IRBDP MH6 UI, LeanID on page 115</i>						

2 Installation

2.2.4.1 Fitting the attachments of the IRBDP MH1 LI

2.2.4 Installation of IRBDP MH1 LI and IRBDP MH2 LI

2.2.4.1 Fitting the attachments of the IRBDP MH1 LI

Location

The location of the attachments of the cable packages IRBDP MH1 LI are shown in the figure.

The figure shows the internal IRBDP MH1 LI fitted on IRB 6600 but the principle assembly is the same on IRB 7600 and 6650S.

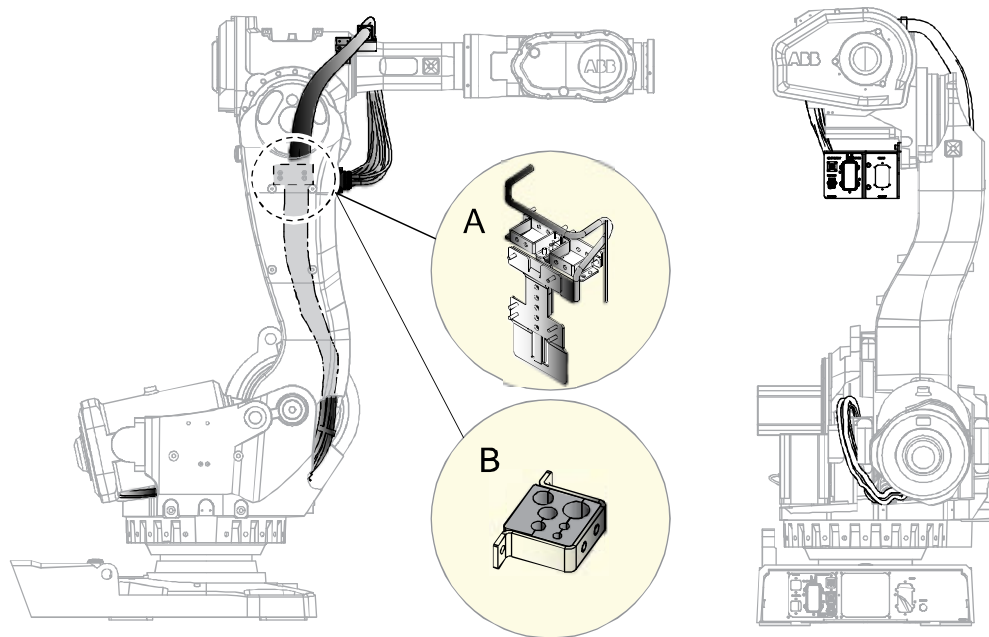

xx100000098

A	Cable bracket (IRB 6650S).
B	Cable bracket (IRB 7600). Already fitted on the cable package when delivered.

Required tools

Equipment	Article number	Note
Standard toolkit, DressPack	3HAC17290-7	The contents are defined in section Toolkits, DressPack on page 357 .

Required spare parts

Spare part	Article number	Note
Material set cable package IRBDP MH1 LI		See DressPack for lower arm MH - IRBDP MH1 LI on page 363

Continues on next page

Required consumables

Consumable	Article number	Note
Locking liquid	3HAB7116-1	Loctite 243. For locking screws securing brackets and connection plate.

Fitting the lower arm cable attachments, IRBDP MH1 LI

This procedure describes how to install the attachments for the cable package IRBDP MH1 LI. All screws are supplied with the kit.

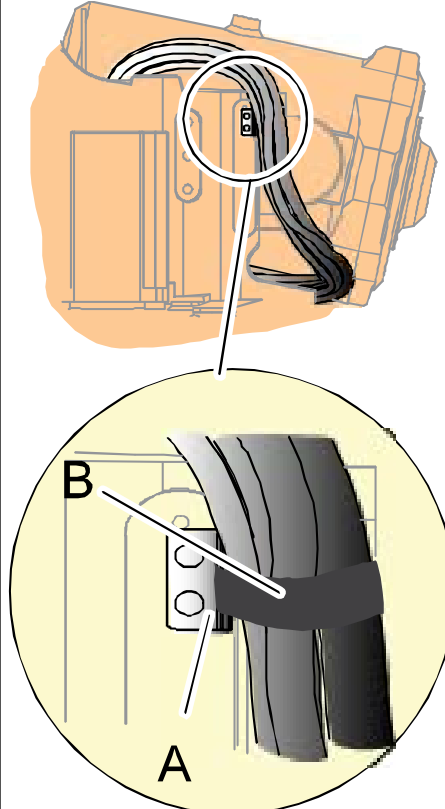
	Action	Note		
1	 DANGER Turn off all: <ul style="list-style-type: none"> • electric power supply • hydraulic pressure supply • air pressure supply to the robot, before entering the robot working area.			
2	Fit the cable fixing bracket to the frame with its attachment screws.	 <p>xx1000000118</p> <table border="1"> <tr> <td>A</td> <td>Cable fixing bracket</td> </tr> </table>	A	Cable fixing bracket
A	Cable fixing bracket			

Continues on next page

2 Installation

2.2.4.1 Fitting the attachments of the IRBDP MH1 LI

Continued

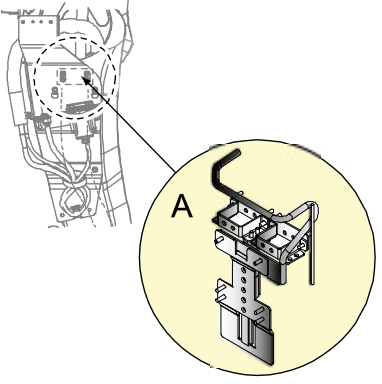
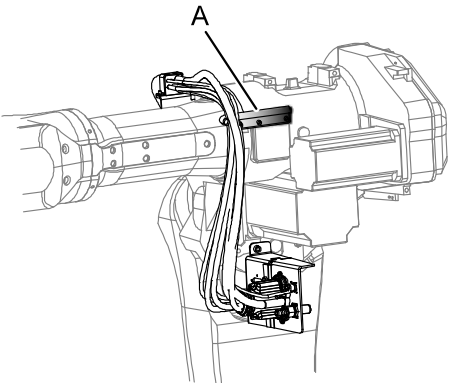
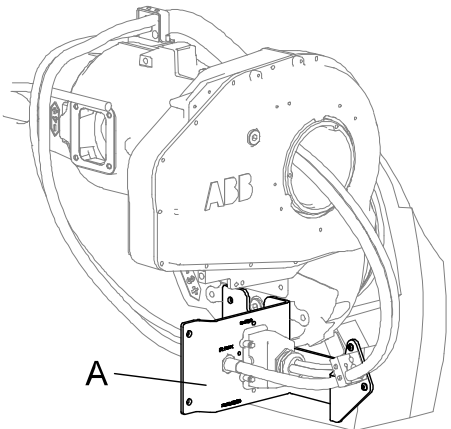
	Action	Note				
3	Fit the cable bracket inside the lower arm with its attachment screws. Lock screws with locking liquid.	 <p data-bbox="957 698 1061 716">xx100000104</p> <table border="1" data-bbox="957 734 1410 784"> <tr> <td data-bbox="957 734 1005 784">A</td> <td data-bbox="1005 734 1410 784">Cable bracket</td> </tr> </table>	A	Cable bracket		
A	Cable bracket					
4	Fit the cable guide on the upper arm.	 <p data-bbox="957 1198 1061 1216">xx100000119</p> <table border="1" data-bbox="957 1234 1410 1283"> <tr> <td data-bbox="957 1234 1005 1283">A</td> <td data-bbox="1005 1234 1410 1283">Cable guide</td> </tr> </table>	A	Cable guide		
A	Cable guide					
5	Fit the connection plate to axis 3 with its attachment screws. Lock screws with locking liquid.	 <p data-bbox="957 1747 1061 1765">xx070000365</p> <table border="1" data-bbox="957 1783 1410 1904"> <tr> <td data-bbox="957 1783 1005 1904">A</td> <td data-bbox="1005 1783 1410 1904">Connection plate</td> </tr> <tr> <td data-bbox="1005 1836 1410 1904"></td> <td data-bbox="1005 1836 1410 1904">Screw, M10x16, quality 8.8-A3F (2 pcs)</td> </tr> </table>	A	Connection plate		Screw, M10x16, quality 8.8-A3F (2 pcs)
A	Connection plate					
	Screw, M10x16, quality 8.8-A3F (2 pcs)					

2.2.4.2 Fitting the attachments of IRBDP MH2 LI

Location

The location of the attachments of the cable package IRBDP MH2 LI is shown in the figure.

The figure shows IRBDP MH2 LI fitted on IRB 6600 but the principle assembly is the same on IRB 7600 and 6650S.

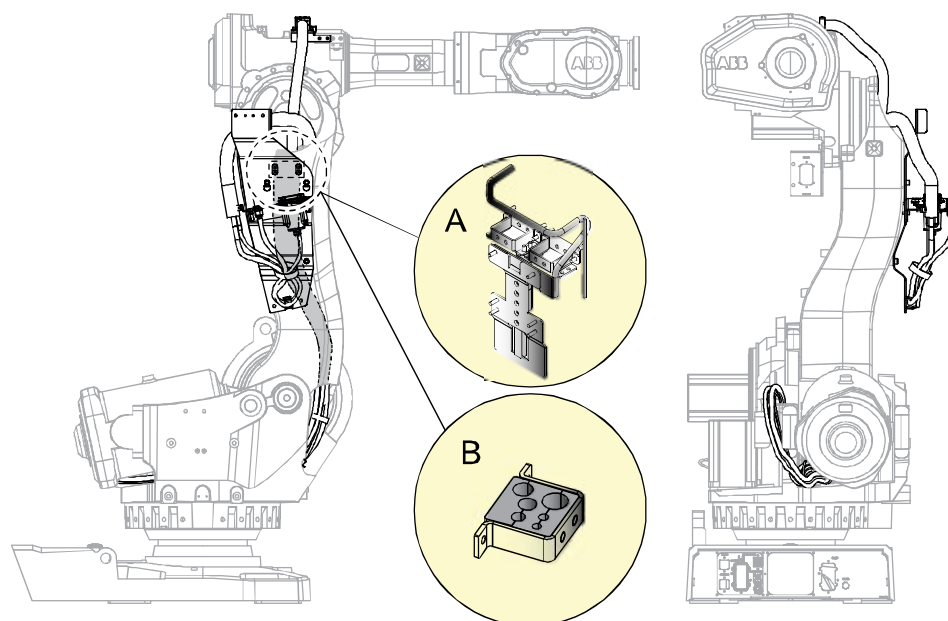

xx100000099

A	Cable bracket (IRB 6650S)
B	Cable bracket (IRB 7600). Already fitted on the cable package when delivered.

Required equipment

Equipment	Art. no.	Note
Locking liquid	3HAB7116-1	Loctite 243 For locking screws securing brackets and connection plate.
Standard toolkit, DressPack	3HAC17290-7	The contents are defined in section Toolkits, DressPack on page 357 .
Other tools and procedures may be required. See references to these procedures in the step-by-step instructions below.		These procedures include references to the tools required.

Continues on next page

2 Installation

2.2.4.2 Fitting the attachments of IRBDP MH2 LI

Continued

Fitting the lower arm cable attachments

Use this procedure to install the attachments for the cable package IRBDP MH2 LI.

	Action	Information
1	 DANGER Turn off all: <ul style="list-style-type: none">• electric power supply• hydraulic pressure supply• air pressure supply to the robot, before entering the robot working area.	

Continues on next page

	Action	Information
2	<p>Fit the <i>lower arm plate</i> to the lower arm with its attachments screws.</p> <p>Depending on the robot model, use washers <i>between</i> the lower arm plate and robot:</p> <ul style="list-style-type: none"> • IRB 7600: two washers • IRB 6650S: washers not needed. <p>Lock the screws with locking liquid (Loctite 243).</p> <p>The screws are supplied with the kit.</p>	<p>xx0500001419</p> <p>The figure shows IRB 7600.</p> <p>Parts:</p> <ul style="list-style-type: none"> • A: Lower arm plate • B: Attachment screws M12x35 8.8-A3F (2 pcs) • C: Attachment screws M12x25 8.8-A3F (2 pcs) • D: (Only used on IRB 7600) Washers (2 pcs) <p>xx0700000327</p> <p>The figure shows IRB 6650S.</p> <p>Parts:</p> <ul style="list-style-type: none"> • A: Lower arm plate • B: Attachment screws M12x25 8.8-A3F (4 pcs)

Continues on next page

2 Installation

2.2.4.2 Fitting the attachments of IRBDP MH2 LI

Continued

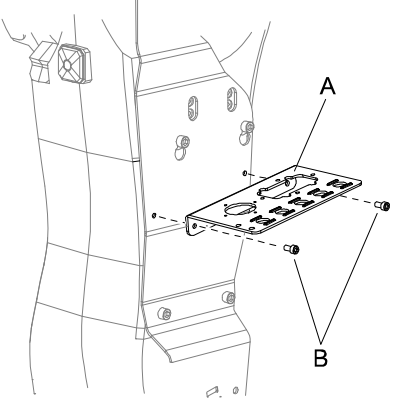
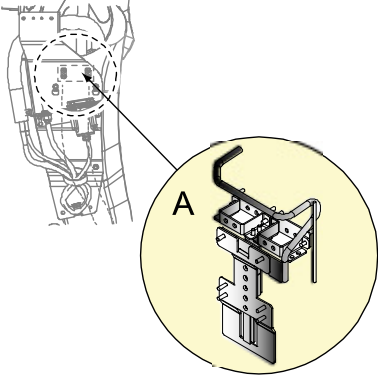
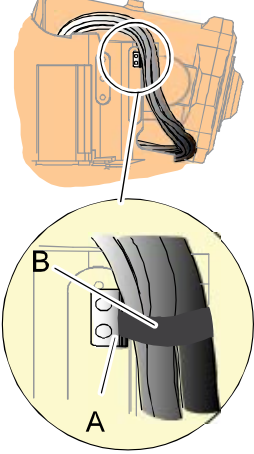
	Action	Information
3	Fit the <i>connection plate</i> on the lower arm plate.	 <p>xx0500001541</p> <p>Parts:</p> <ul style="list-style-type: none">• A: Connection plate• B: Attachment screws (2 pcs)
4	Only applicable to IRB 6650S. Fit the <i>cable bracket</i> inside the lower arm with its attachment screws. Lock the screws with locking liquid (Loctite 243).	 <p>xx1000000104</p> <p>Parts:</p> <ul style="list-style-type: none">• A: Cable bracket
5	Fit the cable fixing bracket to the frame with its attachment screws.	 <p>xx1000000118</p> <p>Parts:</p> <ul style="list-style-type: none">• A: Cable fixing bracket

2.2.4.3 Fitting the cable packages IRBDP MH1 LI and MH2 LI

Introduction

This procedure describes (in two steps) how to fit the lower arm internal process cable packages:

- IRBDP MH1 LI and
- IRBDP MH2 LI.

How to fit the attachments for the cable packages is described in *Fitting the attachments of IRBDP MH1 LI and IRBDP MH2 LI*.

Location of the cable package IRBDP MH1 LI

The lower arm internal process cable package IRBDP MH1 LI is located as shown in the illustration.

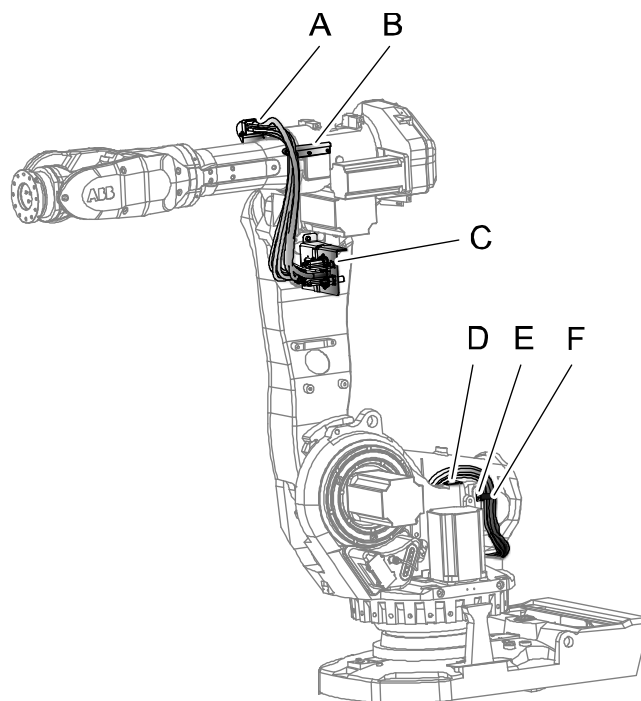

xx1000000123

A	Cable bracket
B	Cable guide and strap
C	Connection plate
D	Bracket
E	Cable fixing bracket
F	Strap

Continues on next page

2 Installation

2.2.4.3 Fitting the cable packages IRBDP MH1 LI and MH2 LI

Continued

Location of the cable package IRBDP MH2 LI

The lower arm internal process cable package IRBDP MH2 LI is located as shown in the illustration.

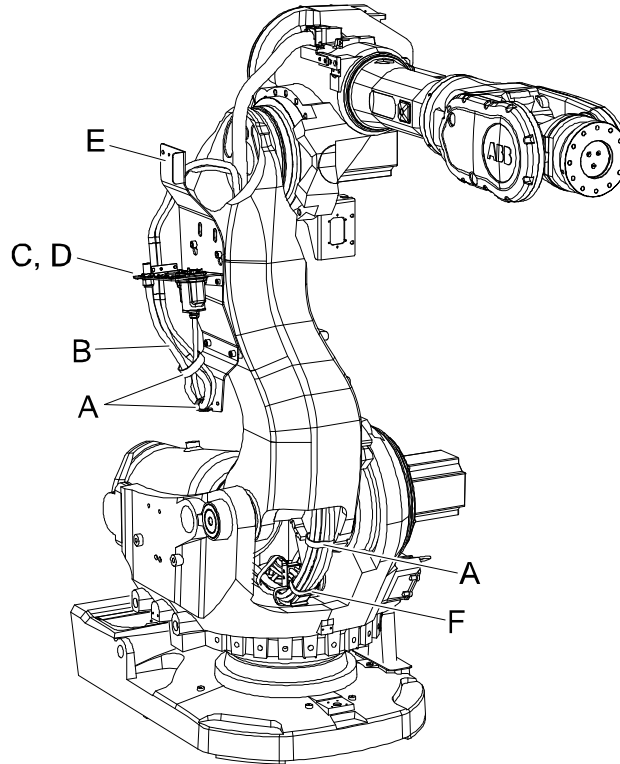

xx0500001534

A	Velcro straps
B	Lower arm internal cable package
C	Cable fixing bracket
D	Connection plate
E	Lower arm plate
F	Cable bracket, base frame

Required equipment

Equipment	Note
Lower arm internal process cable package	See Spare Parts. A number of variants are available.
Standard toolkit, DressPack	The content is described in section <i>Toolkit, DressPack</i> .
Other tools and procedures may be required. See references to these procedures in the step-by-step instructions below.	These procedures include references to the tools required.
Locking liquid (Loctite 243)	For locking attachment screws specified in the procedure.



Continues on next page

Equipment	Note
Circuit diagram	Art. no. 3HAC026209-001

Fitting the cable packages IRBDP MH1 LI and MH2 LI - the first part

Use these procedures to fit the first part of the lower arm internal process cable packages IRBDP MH1 LI and MH2 LI.

All screws are supplied in the kit.

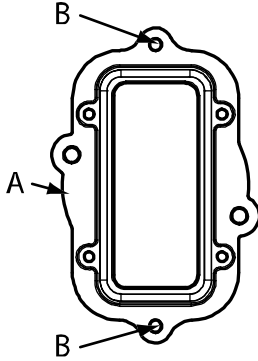

	Action	Note
1	 DANGER Turn off all: <ul style="list-style-type: none"> • electric power supply • hydraulic pressure supply • air pressure supply to the robot, before entering the robot working area.	
2	 CAUTION The cable package is sensitive to mechanical damage. They must be handled with care, especially the connectors, in order to avoid damaging them.	
3	Fit the adapter complete to the <i>customer plate</i> with two attachment screws.	 <p>xx0300000195</p> <p>Parts:</p> <ul style="list-style-type: none"> • A: Adapter complete • B: Attachment screws M6x16 (2 pcs)

Continues on next page

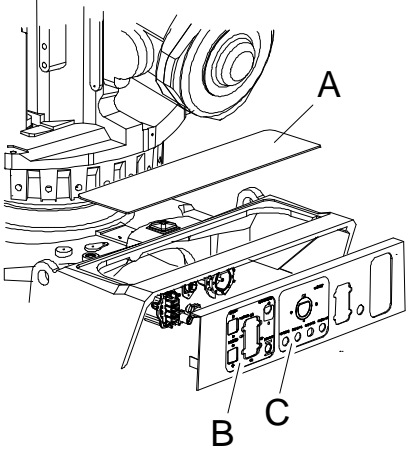

2 Installation

2.2.4.3 Fitting the cable packages IRBDP MH1 LI and MH2 LI

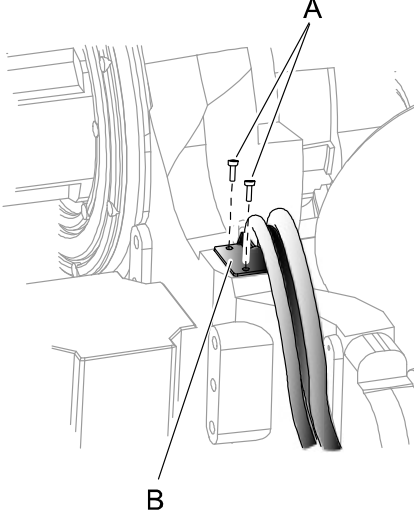
Continued

	Action	Note
4	Remove the <i>cover plate</i> in the back of the robot base.	 <p>xx0500001422</p> <p>Parts:</p> <ul style="list-style-type: none"> • A: Cover plate • B: Customer plate • C: Process plate (not included with MH)
5	Remove the blank <i>cover plate</i> and replace it with the <i>customer plate</i> . Use the existing screws.	
6	 Note Make sure that no cables and hoses are twisted.	
7	Fit the cables down through the centre hole of gearbox axis 1.	
8	Attach the <i>cable and hose clamp</i> with its <i>attachment screws</i> . Lock the screws with <i>locking liquid</i> .	 <p>xx0500001538</p> <p>Parts:</p> <ul style="list-style-type: none"> • A: Attachment screws (2 pcs) • B: Cable and hose clamp

Continues on next page

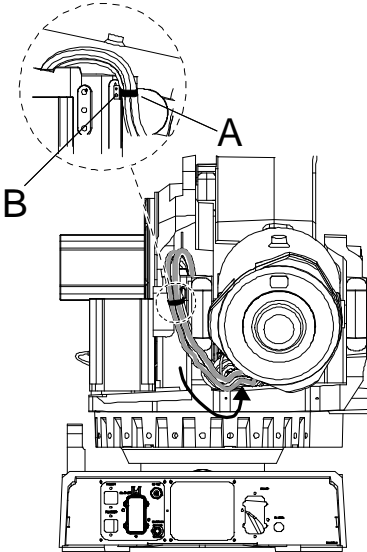

	Action	Note
9	<p>Fit the connectors to the <i>customer plate and process plate</i>, previously fitted to the <i>connection plate, base</i>.</p> <p> CAUTION</p> <p>Do not tighten the brass couplings for water and air with excessive force.</p> <p> CAUTION</p> <p>If the M12 Ethernet connector is not tightened correctly, there is a risk that the connector can loosen and the cable shield gets disconnected, which will require retightening with the correct torque tools.</p> <p>For secure connection, always tighten at the knurled screw with correct torque and by using proper torque tool, e.g. M12 dynamometric screwdriver SW15 (09 99 000 0646 (article number at Harting Technology Group)).</p>	<p>Tightening torque:</p> <ul style="list-style-type: none"> • Brass coupling 1/2": 31 Nm. • Stainless steel coupling 1/2": 49 Nm. • Brass coupling 3/8": 17 Nm. • Mixed metals: Use the lower tightening torque value of the two metals. <p>Always apply Molykote P1900 to stainless steel couplings and apply if needed for couplings of mixed metals or brass.</p> <p>Tightening torque, Ethernet M12: 0.6 Nm.</p> <p>Recheck all cables and hoses for straining or twisting. Reroute if required!</p> <p>Screw dimension: M6x20 (2 pcs)</p>
10	<p>Push in the upper end of the cable package between the balancing cylinder and the robots base frame.</p>	 <p>xx0500001540</p> <p>Parts:</p> <ul style="list-style-type: none"> • A: Cable fixing bracket with strap • B: Attachment screws (1 pcs)

Continues on next page

2 Installation

2.2.4.3 Fitting the cable packages IRBDP MH1 LI and MH2 LI

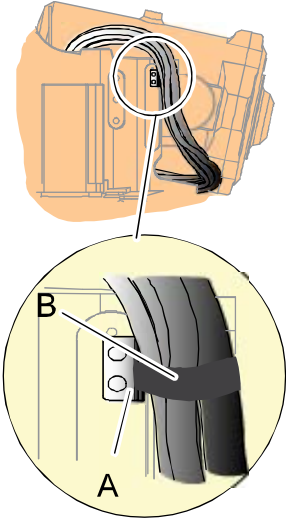
Continued

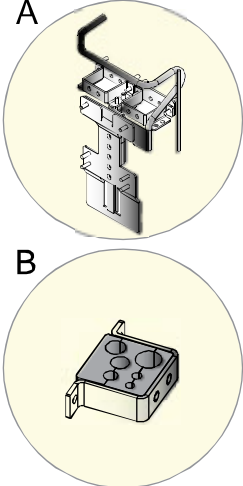
	Action	Note
11	Secure the cable package to the <i>cable fixing bracket</i> with a <i>strap</i> .	 <p data-bbox="981 835 1086 853">xx1000000118</p> <p data-bbox="981 875 1046 898">Parts:</p> <ul data-bbox="1013 902 1305 958" style="list-style-type: none"> • A: Cable fixing bracket • B: Strap
12	Strap the cabling with two velcro straps inside axis 1, to avoid cable chafing on the screw.	
13	Push the cable package with connectors up through the inside of the lower arm.	
14	 Note Make sure that no cables and hoses are twisted.	
15	Fit the cables in the existing <i>cable bracket</i> on the inside of the lower arm.	 <p data-bbox="981 1787 1086 1805">xx1000000120</p> <p data-bbox="981 1827 1046 1850">Parts:</p> <ul data-bbox="1013 1854 1369 1964" style="list-style-type: none"> • A: Cable bracket, IRB 6650S • B: Cable bracket, IRB 7600 (already fitted on the cable package when delivered)

Continues on next page

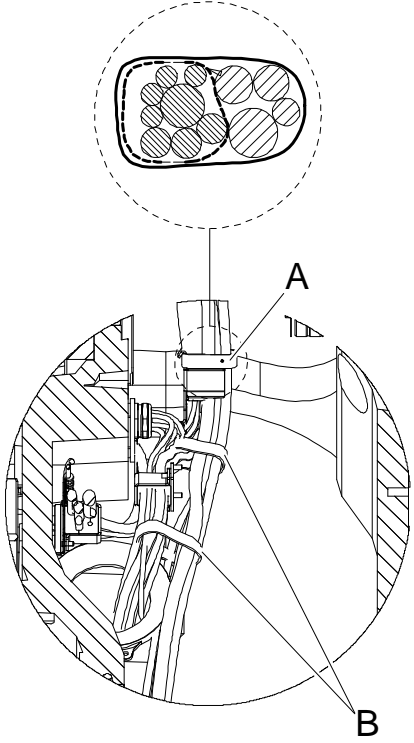
	Action	Note
16	<p>Route the cables and attach them in the lower existing bracket on the inside of the base frame with the velcro straps.</p> <p> Note</p> <p>Keep the existing strap!</p>	 <p>xx0500001546</p> <p>Parts:</p> <ul style="list-style-type: none"> • A: Existing + New velcro strap • B: Velcro straps

Continues on next page

2 Installation

2.2.4.3 Fitting the cable packages IRBDP MH1 LI and MH2 LI

Continued

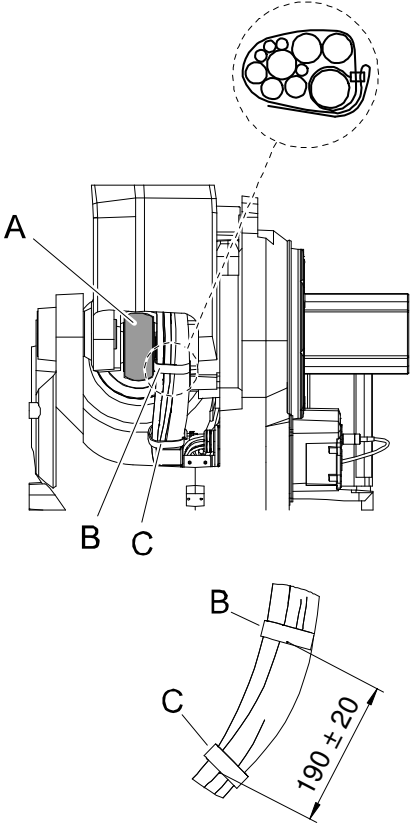

	Action	Note
17	<p>Fit the protection cover on the balancing cylinder ear.</p> <p> Note</p> <p>When fitting the cable package in, make sure to have one extra turn around air hose to fixate the upper velcro strap.</p> <p>The illustration also shows the measure between the upper and lower strap.</p>	 <p>xx0500001798</p> <p>Parts:</p> <ul style="list-style-type: none"> • A: Protection cover • B: Existing strap (upper) • C: Existing strap (lower)
18	<p>Continue with step two of fitting the process cable package, depending on variant.</p>	<p>Depending on which cable harness is used, continue with step two at:</p> <ul style="list-style-type: none"> • IRBDP MH1 LI: Fitting the cable package IRBDP MH1 LI - the second part on page 56 • IRBDP MH2 LI: Fitting the cable package IRBDP MH2 LI - the second part on page 58

Fitting the cable package IRBDP MH1 LI - the second part

Use this procedure to continue with the second part of fitting the lower arm internal process cable package IRBDP MH1 LI.

	Action	Note
1	<p>Secure the cable package to the upper arm with the <i>cable bracket</i>.</p>	<p>See the figure in:</p> <ul style="list-style-type: none"> • Location of the cable package IRBDP MH1 LI on page 49

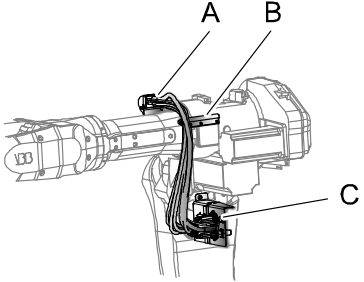
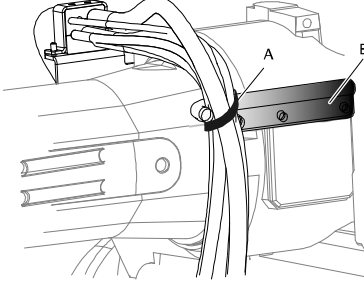
Continues on next page

	Action	Note
2	Arrange the cable package over the upper arm and put it in the cable guide.	 <p>xx1000000127</p> <p>Parts:</p> <ul style="list-style-type: none"> • A: Cable bracket • B: Cable guide • C: Connection plate
3	Secure the cable package to the cable guide with a strap.	 <p>xx1000000128</p> <p>Parts:</p> <ul style="list-style-type: none"> • A: Strap • B: Cable guide
4	<p>Fit the cable harness connectors to the connection plate.</p> <p> CAUTION</p> <p>Do not tighten the brass couplings for water and air with excessive force.</p> <p> CAUTION</p> <p>If the M12 Ethernet connector is not tightened correctly, there is a risk that the connector can loosen and the cable shield gets disconnected, which will require retightening with the correct torque tools.</p> <p>For secure connection, always tighten at the knurled screw with correct torque and by using proper torque tool, e.g. M12 dynamometric screwdriver SW15 (09 99 000 0646 (article number at Harting Technology Group)).</p>	<p>Tightening torque:</p> <ul style="list-style-type: none"> • Brass coupling 1/2": 31 Nm. • Stainless steel coupling 1/2": 49 Nm. • Brass coupling 3/8": 17 Nm. • Mixed metals: Use the lower tightening torque value of the two metals. <p>Always apply Molykote P1900 to stainless steel couplings and apply if needed for couplings of mixed metals or brass.</p> <p>Tightening torque, Ethernet M12: 0.6 Nm.</p> <p>See the figure in:</p> <ul style="list-style-type: none"> • Location of the cable package IRBDP MH1 LI on page 49

2 Installation



2.2.4.3 Fitting the cable packages IRBDP MH1 LI and MH2 LI

Continued

Fitting the cable package IRBDP MH2 LI - the second part

Use this procedure to continue with the second part of fitting the lower arm internal process cable package IRBDP MH2 LI.

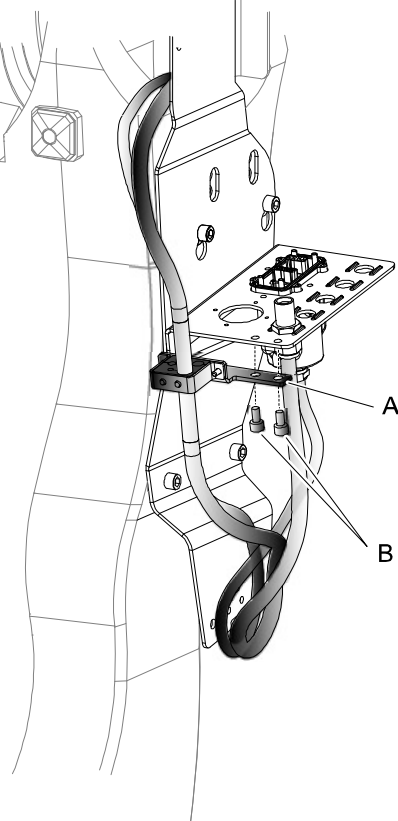
All screws are supplied with the kit.

	Action	Note
1	<p>Fit the <i>cable fixing bracket</i> on the connection plate with the two attachment screws.</p>	 <p>xx0500001544</p> <p>Parts:</p> <ul style="list-style-type: none"> • A: Cable fixing bracket • B: Attachment screws (2 pcs)
2	<p>Fit the hose and cable connectors to the connection plate.</p> <p> CAUTION</p> <p>Do not tighten the brass couplings for water and air with excessive force.</p> <p> CAUTION</p> <p>If the M12 Ethernet connector is not tightened correctly, there is a risk that the connector can loosen and the cable shield gets disconnected, which will require retightening with the correct torque tools.</p> <p>For secure connection, always tighten at the knurled screw with correct torque and by using proper torque tool, e.g. M12 dynamometric screwdriver SW15 (09 99 000 0646 (article number at Harting Technology Group)).</p>	<p>Tightening torque:</p> <ul style="list-style-type: none"> • Brass coupling 1/2": 31 Nm. • Stainless steel coupling 1/2": 49 Nm. • Brass coupling 3/8": 17 Nm. • Mixed metals: Use the lower tightening torque value of the two metals. <p>Always apply Molykote P1900 to stainless steel couplings and apply if needed for couplings of mixed metals or brass.</p> <p>Tightening torque, Ethernet M12: 0.6 Nm.</p>

Continues on next page

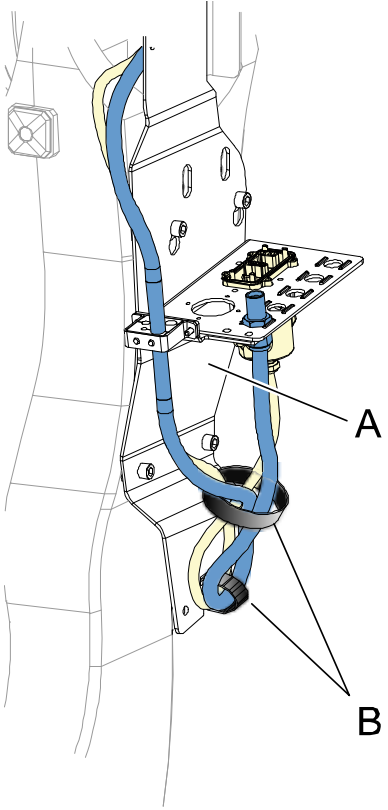
	Action	Note
3	Route the cables as shown in the illustration.	 <p data-bbox="1023 1122 1129 1144">xx0500001545</p> <p data-bbox="1023 1160 1090 1182">Parts:</p> <ul data-bbox="1054 1189 1305 1249" style="list-style-type: none"> • A: Lower arm plate • B: Velcro straps
4	Strap the cables to the lower arm plate with the two <i>velcro straps</i> .	

2 Installation

2.2.5.1 Fitting the attachments of the IRBDP MH3 UE

2.2.5 Installation of IRBDP MH3 UE

2.2.5.1 Fitting the attachments of the IRBDP MH3 UE

Location

The location of the attachments of the cable package IRBDP MH3 UE is shown in the figure.

The figure shows the MH3 dressing cable package fitted on IRB 7600.

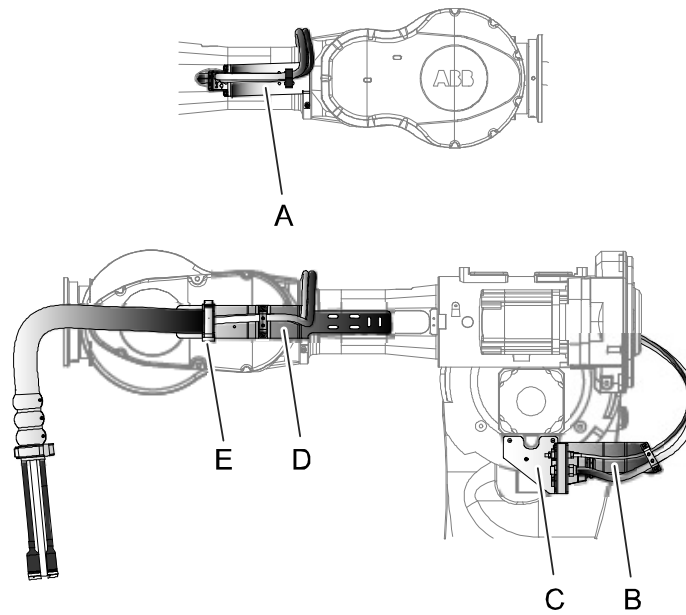

xx100000105

A	Bracket right
B	Bracket for metal clamp
C	Connection plate, axis 3
D	Bracket left
E	Gripping clamp

Continues on next page

On versions IRB6650S-125/3.5, IRB6650S-100/3.5 LID and IRB 7600-150/3.5 an extra bracket is needed.

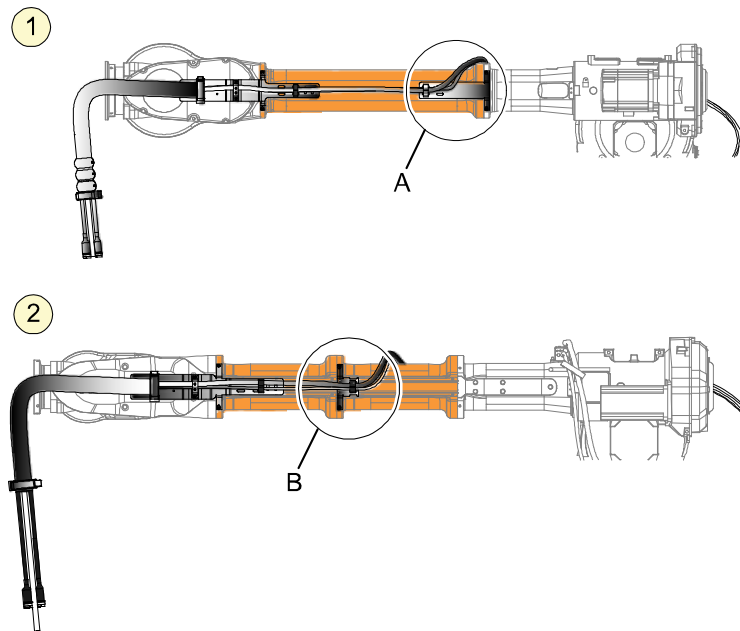

xx1000000107

1	IRB 7600-150/3.5
A	Bracket
2	IRB 6650S-125/3.5, IRB6650S-100/3.5 LID
B	Bracket

Required tools

Equipment	Article number	Note
Standard toolkit, DressPack	3HAC17290-7	The contents are defined in section Toolkits, DressPack on page 357 .

Required spare parts

Spare part	Article number	Note
Material set cable package IRBDP MH3 UE		See DressPack upper arm MH - IRBDP MH3 UE on page 370

Required consumables

Consumable	Article number	Note
Locking liquid	3HAB7116-1	Loctite 243. For locking screws securing brackets and connection plate.

Continues on next page

2 Installation

2.2.5.1 Fitting the attachments of the IRBDP MH3 UE

Continued

Fitting the upper arm cable attachments, IRBDP MH3 UE

This procedure describes how to install the attachments of the cable package IRBDP MH3 UE. Screws are supplied with the kit.

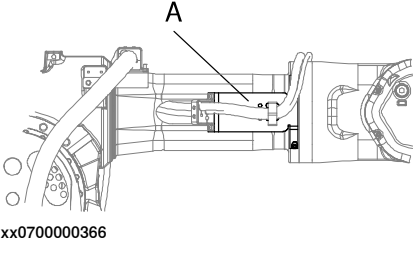
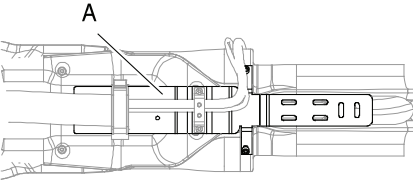
	Action	Note				
1	 DANGER Turn off all: <ul style="list-style-type: none"> • electric power supply • hydraulic pressure supply • air pressure supply to the robot, before entering the robot working area.					
2	Fit bracket right with its attachment screws. Lock screws with locking liquid.	 <p>xx0700000366</p> <table border="1" data-bbox="991 1010 1406 1128"> <tr> <td data-bbox="991 1010 1034 1055">A</td> <td data-bbox="1034 1010 1406 1055">Bracket, right</td> </tr> <tr> <td data-bbox="991 1055 1034 1128"></td> <td data-bbox="1034 1055 1406 1128">Screw, M8x16, quality 8.8-A2F (2 pcs)</td> </tr> </table>	A	Bracket, right		Screw, M8x16, quality 8.8-A2F (2 pcs)
A	Bracket, right					
	Screw, M8x16, quality 8.8-A2F (2 pcs)					
3	Fit bracket left with its attachment screws. Lock screws with locking liquid.	 <p>xx0700000367</p> <table border="1" data-bbox="991 1375 1406 1494"> <tr> <td data-bbox="991 1375 1034 1420">A</td> <td data-bbox="1034 1375 1406 1420">Bracket, left</td> </tr> <tr> <td data-bbox="991 1420 1034 1494"></td> <td data-bbox="1034 1420 1406 1494">Screw, M8x16, quality 8.8-A2F (2 pcs)</td> </tr> </table>	A	Bracket, left		Screw, M8x16, quality 8.8-A2F (2 pcs)
A	Bracket, left					
	Screw, M8x16, quality 8.8-A2F (2 pcs)					

Continues on next page

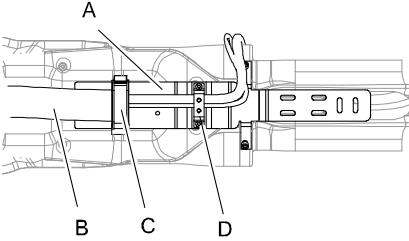
	Action	Note										
4	<p>Fit a gripping clamp on the bracket, left, with its attachment screws. Lock screw with locking liquid.</p>	 <p>xx0700000372</p> <table border="1" data-bbox="1023 595 1437 846"> <tr> <td>A</td> <td>Bracket, left</td> </tr> <tr> <td>B</td> <td>Protection hose</td> </tr> <tr> <td>C</td> <td>Gripping clamp</td> </tr> <tr> <td>D</td> <td>Rubber clamp with bracket</td> </tr> <tr> <td></td> <td>Screw, M8x16 quality 8.8-A2F (2 pcs)</td> </tr> </table>	A	Bracket, left	B	Protection hose	C	Gripping clamp	D	Rubber clamp with bracket		Screw, M8x16 quality 8.8-A2F (2 pcs)
A	Bracket, left											
B	Protection hose											
C	Gripping clamp											
D	Rubber clamp with bracket											
	Screw, M8x16 quality 8.8-A2F (2 pcs)											
5	<p>Only applicable to variants IRB 6650S-125/3.5, IRB6650S-100/3.5 LID and 7600-150/3.5. Fit the extra bracket on the upper arm.</p>											

2 Installation

2.2.5.2 Fitting the cable package IRBDP MH3 UE

2.2.5.2 Fitting the cable package IRBDP MH3 UE

Location

The location of the cable package IRBDP MH3 UE is shown in the figure below. How to fit the attachments for the cable package is described in *Fitting the attachments of IRBDP MH3 UE*.

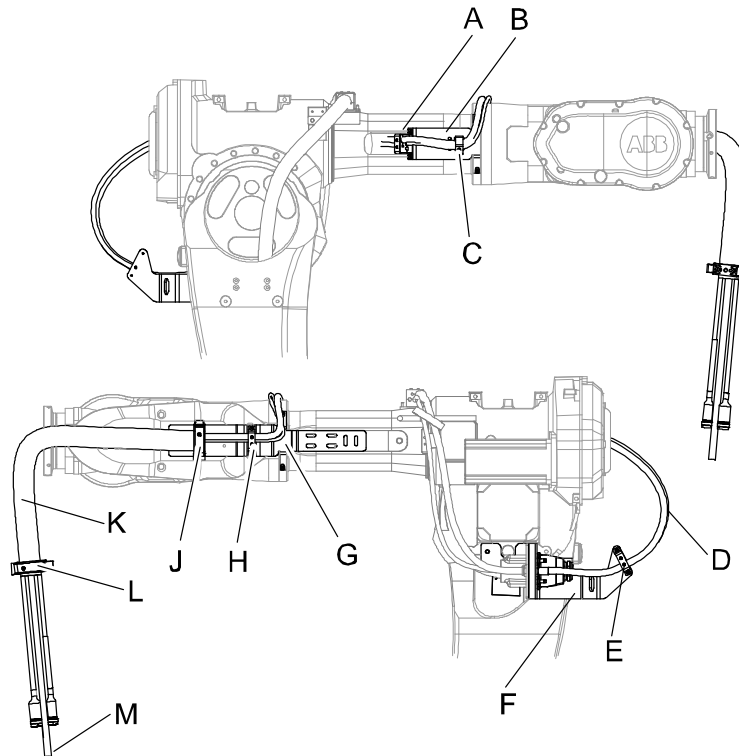

xx0700000379

A	Rubber clamp with bracket
B	Bracket, right
C	Velcro strap
D	Upper cable package
E	Rubber clamp with bracket
F	Connection plate
G	Bracket, left
H	Rubber clamp with bracket
J	Gripping clamp (bracket left)
K	Protection hose
L	Gripping clamp (protection hose)
M	Air hose

Continues on next page

Spare parts

Equipment, etc.	Art. no.	Note
Cable package IRBDP MH3 UE.	Spare part number is specified in: <ul style="list-style-type: none"> • Spare parts on page 361. 	

Required tools and equipment



Equipment, etc.	Art. no.	Note
Standard toolkit	-	Content is defined in section Standard toolkit on page 357.
Other tools and procedures may be required. See references to these procedures in the step-by-step instructions below.		These procedures include references to the tools required.

Consumables

Equipment, etc.	Art. no.	Note
Locking liquid	3HAB7116-1	Loctite 243 For locking attachment screws.

Fitting the cable package IRBDP MH3 UE

Use this procedure to fit the cable package IRBDP MH3 UE.





	Action	Note
1	 DANGER Turn off all: <ul style="list-style-type: none"> • electric power supply • hydraulic pressure supply • air pressure supply to the robot, before entering the robot working area.	
2	 CAUTION The cable package is sensitive to mechanical damage. They must be handled with care, especially the connectors, in order to avoid damaging them.	

Continues on next page

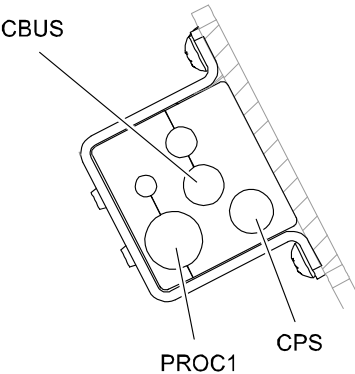

2 Installation

2.2.5.2 Fitting the cable package IRBDP MH3 UE

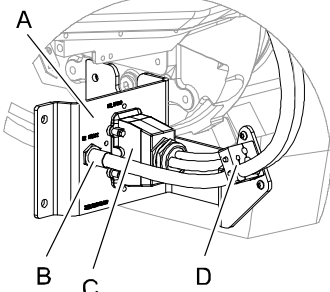
Continued

	Action	Note
3	<p>Push the customer signal and power cables as well as air hose into the upper arm tube from the rear, and out of the hole on the side where the <i>right bracket</i> is placed on the upper arm.</p> <p>Arrange the cables and hoses so no cables or hoses are twisted.</p> <p> Note</p> <p>Be careful not to damage the existing motor cables!</p>	<p>Shown in the figure Location on page 64.</p>
4	<p>Connect cables and hoses of the upper cable package, to the <i>connection plate</i>.</p> <p>Fit <i>rubber clamp with bracket</i> on the <i>connection plate</i> with its attachment screws.</p> <p>Lock screws with <i>locking liquid</i>.</p> <p> CAUTION</p> <p>Do not tighten the brass couplings for water and air with excessive force.</p> <p> Note</p> <p>Place cables and hose in the correct position! See figure!</p>  <p>xx0700000369</p> <p> CAUTION</p> <p>If the M12 Ethernet connector is not tightened correctly, there is a risk that the connector can loosen and the cable shield gets disconnected, which will require retightening with the correct torque tools.</p> <p>For secure connection, always tighten at the knurled screw with correct torque and by using proper torque tool, e.g. M12 dynamometric screwdriver SW15 (09 99 000 0646 (article number at Harting Technology Group)).</p>	<p>Tightening torque:</p> <ul style="list-style-type: none"> • Brass coupling 1/2": 31 Nm. • Stainless steel coupling 1/2": 49 Nm. • Brass coupling 3/8": 17 Nm. • Mixed metals: Use the lower tightening torque value of the two metals. <p>Always apply Molykote P1900 to stainless steel couplings and apply if needed for couplings of mixed metals or brass.</p> <p>Tightening torque, Ethernet M12: 0.6 Nm.</p>  <p>xx0700000368</p> <p>Parts:</p> <ul style="list-style-type: none"> • A: Connection plate • B: Hose • C: Signal and power cable • D: Rubber clamp with bracket <p>Screws M6x16 quality 8.8-A2F (2 pcs)</p>

Continues on next page

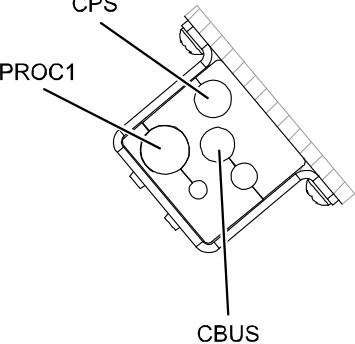
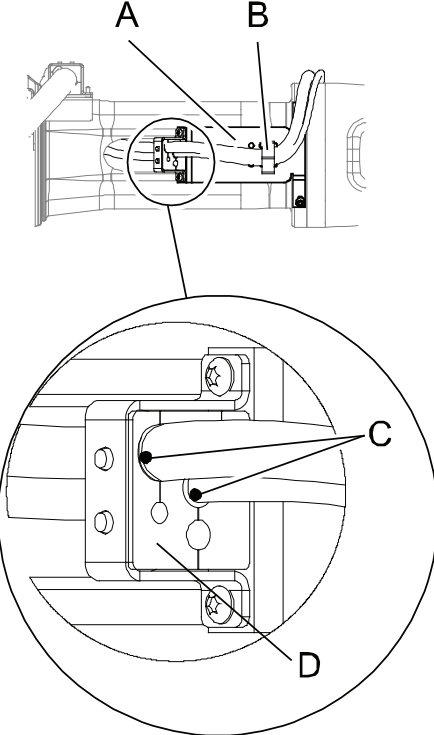
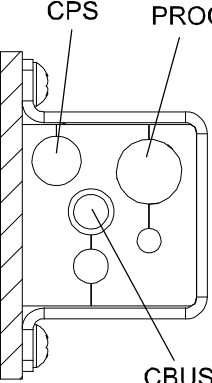
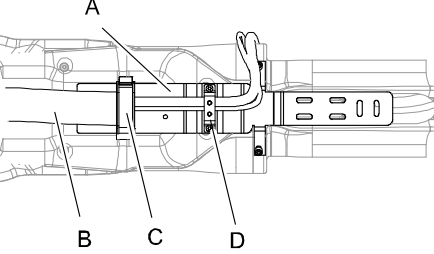
	Action	Note
5	<p>Fit the cables and hose to the <i>bracket right</i> with the <i>rubber clamp with bracket</i> with its attachment screws.</p> <p>Lock screw with <i>locking liquid</i>.</p> <p>Attach the cable package to the bracket with a <i>velcro strap</i>.</p> <p> Note</p> <p>Do not pull the hose when attaching the strap. It may cause restriction of air flow.</p> <p> Note</p> <p>The <i>white markings on cables</i> shall be visible just outside the <i>rubber clamp</i>.</p>  <p>xx0700000371</p>	 <p>xx0700000370</p> <p>Parts:</p> <ul style="list-style-type: none"> • A: Bracket, right • B: Velcro strap • C: White markings on cables • D: Rubber clamp with bracket <p>Screw M6x16 quality 8.8-A2F (2 pcs)</p>
6	<p>Fit the cables and hose to <i>bracket left</i> with the <i>rubber clamp with bracket</i> with its attachment screws.</p> <p>Lock screws with <i>locking liquid</i>.</p>  <p>xx0700000373</p>	 <p>xx0700000372</p> <p>Parts:</p> <ul style="list-style-type: none"> • A: Bracket, left • B: Protection hose • C: Gripping clamp • D: Rubber clamp with bracket <p>Screws M6x16 quality 8.8-A2F (2 pcs)</p>

Continues on next page

2 Installation

2.2.5.2 Fitting the cable package IRBDP MH3 UE

Continued

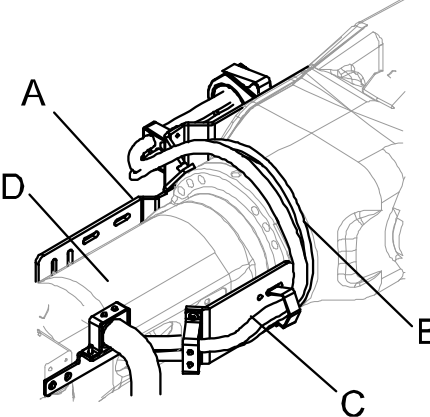
	Action	Note
7	<p>Arrange cable and hose in a way that they form a smooth bend over and close to the upper arm, between the brackets on either side.</p>	 <p>xx070000386</p> <p>Parts:</p> <ul style="list-style-type: none">• A: Bracket, left• B: Arranged cables and hose• C: Bracket, right• D: Upper arm
8	<p>Push the cables and hose through the protection hose and fit them in the gripping clamp on the bracket left.</p>	<p>Shown in the figure above!</p>
9	<p>Fit a gripping clamp at the other end of the protection hose.</p>	<p>Shown in the figure Location on page 64.</p>

2.2.6 Installation of IRBDP MH2 LE and IRBDP SW2 LE

2.2.6.1 Fitting the attachments of IRBDP MH2 LE and IRBDP SW2 LE

**Note**

This section is also valid for how to fit the attachments on the lower end of the cable package IRBDP SW2 CE. Only difference is that the connection plate between upper and lower cable package does not exist since the harness is continuous.

Location of the attachments of IRBDP MH2 LE and IRBDP SW2 LE

The location of the attachments of the cable packages IRBDP MH2 LE and SW2 LE are shown in the figure.

Figure shows IRB 7600.

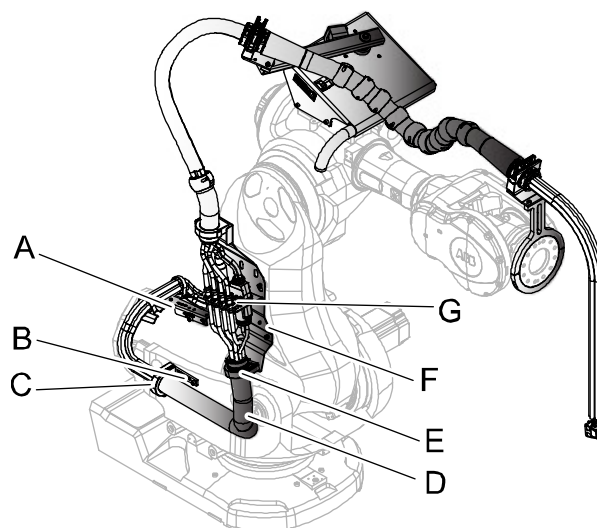
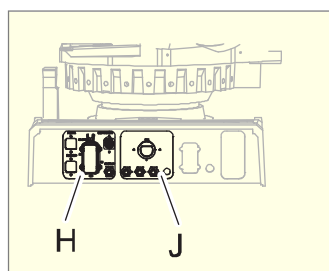
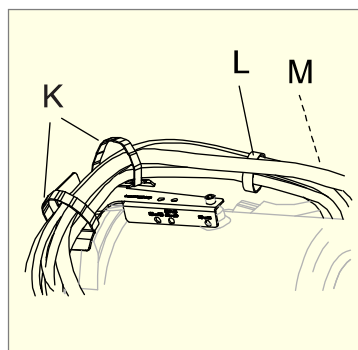

xx080000151

A	Attachment, balancing device
B	Turn plate
C	Gripping clamp
D	Process cable package, lower arm
E	Gripping clamp
F	Lower arm plate
G	Connection plate
H	Customer plate

Continues on next page

2 Installation

2.2.6.1 Fitting the attachments of IRBDP MH2 LE and IRBDP SW2 LE

Continued

J	Process plate
K	Velcro straps
L	Straps

Required spare parts

Spare part	Article number	Note
Material set cable package IRBDP MH2 LE/IRBDP SW2 LE		

Required tools

The following equipment is required for fitting the lower arm cable package attachments.

Equipment	Art. no.	Note
Standard toolkit, DressPack	3HAC17290-7	The contents are defined in section Toolkits, DressPack on page 357 .

Consumables

Consumable	Article number	Note
Locking liquid	3HAB7116-1	Loctite 243. For locking the screws.

Procedure

This procedure describes how to install the attachments for the cable packages IRBDP MH2 LE and SW2 LE. The screws are supplied with the kit.

	Action	Note
1	 DANGER Turn off all: <ul style="list-style-type: none">• electric power supply• hydraulic pressure supply• air pressure supply to the robot, before entering the robot working area.	

Continues on next page

2.2.6.1 Fitting the attachments of IRBDP MH2 LE and IRBDP SW2 LE

Continued

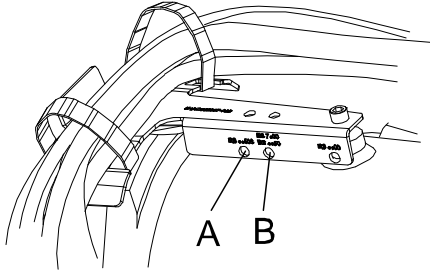
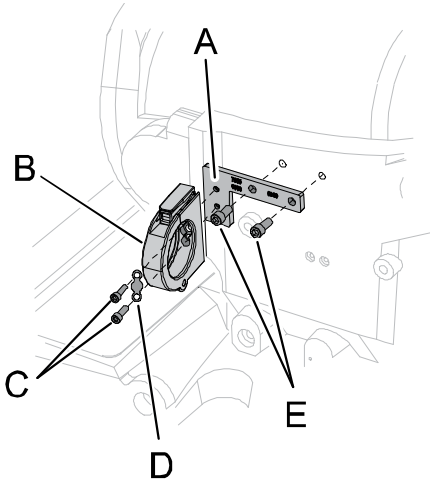
	Action	Note										
2	<p>Fit the cable package attachment on the balancing cylinder with the attachment screw. Lock the screws with locking liquid.</p>	<p>Shown in the figure in section Location of the attachments of IRBDP MH2 LE and IRBDP SW2 LE on page 69</p>  <p>xx080000153</p> <table border="1" data-bbox="1002 712 1436 806"> <tr> <td>A</td> <td>Attachment IRB 6650S</td> </tr> <tr> <td>B</td> <td>Attachment IRB 7600</td> </tr> </table>	A	Attachment IRB 6650S	B	Attachment IRB 7600						
A	Attachment IRB 6650S											
B	Attachment IRB 7600											
3	<p>Fit the gripping clamp to the turn plate and attach it to the frame of the robot. The mounting direction of the turn plate varies from robot to robot. The text on the turn plate should be turned correctly depending on robot model when mounted. Lock the screws with locking liquid.</p>	<p>Shown in the figure in section Location of the attachments of IRBDP MH2 LE and IRBDP SW2 LE on page 69</p>  <p>xx0500001416</p> <table border="1" data-bbox="1002 1451 1436 1675"> <tr> <td>A</td> <td>Turn plate</td> </tr> <tr> <td>B</td> <td>Gripping clamp</td> </tr> <tr> <td>C</td> <td>Gripping clamp Screw (2 pcs)</td> </tr> <tr> <td>D</td> <td>Washer 2 holes</td> </tr> <tr> <td>E</td> <td>Turn plate screw (2 pcs)</td> </tr> </table>	A	Turn plate	B	Gripping clamp	C	Gripping clamp Screw (2 pcs)	D	Washer 2 holes	E	Turn plate screw (2 pcs)
A	Turn plate											
B	Gripping clamp											
C	Gripping clamp Screw (2 pcs)											
D	Washer 2 holes											
E	Turn plate screw (2 pcs)											

Continues on next page

2 Installation

2.2.6.1 Fitting the attachments of IRBDP MH2 LE and IRBDP SW2 LE

Continued

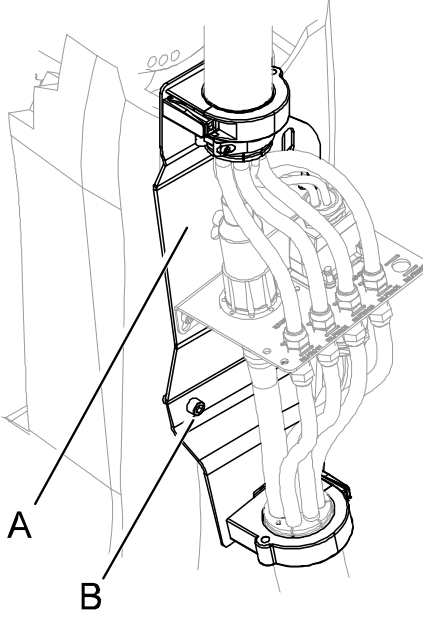
	Action	Note						
4	Fit the lower arm plate to the lower arm with its attachment screws. Lock the screws with locking liquid.	 <p data-bbox="976 936 1082 958">xx0700000327</p> <table border="1" data-bbox="976 974 1401 1189"><tbody><tr><td data-bbox="976 974 1023 1014">A</td><td data-bbox="1023 974 1401 1014">Lower arm plate</td></tr><tr><td data-bbox="976 1014 1023 1093">B</td><td data-bbox="1023 1014 1401 1093">Screw, M12x25, quality 8.8-A3F (4 pcs) (short upper arm)</td></tr><tr><td data-bbox="976 1093 1023 1189">C</td><td data-bbox="1023 1093 1401 1189">Screws, M12x25 (2 pcs) and M12x35 (2 pcs) with 2 washers, quality 8.8-A3F (long upper arm)</td></tr></tbody></table>	A	Lower arm plate	B	Screw, M12x25, quality 8.8-A3F (4 pcs) (short upper arm)	C	Screws, M12x25 (2 pcs) and M12x35 (2 pcs) with 2 washers, quality 8.8-A3F (long upper arm)
A	Lower arm plate							
B	Screw, M12x25, quality 8.8-A3F (4 pcs) (short upper arm)							
C	Screws, M12x25 (2 pcs) and M12x35 (2 pcs) with 2 washers, quality 8.8-A3F (long upper arm)							

Continues on next page

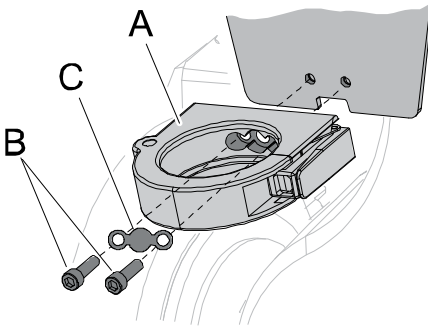
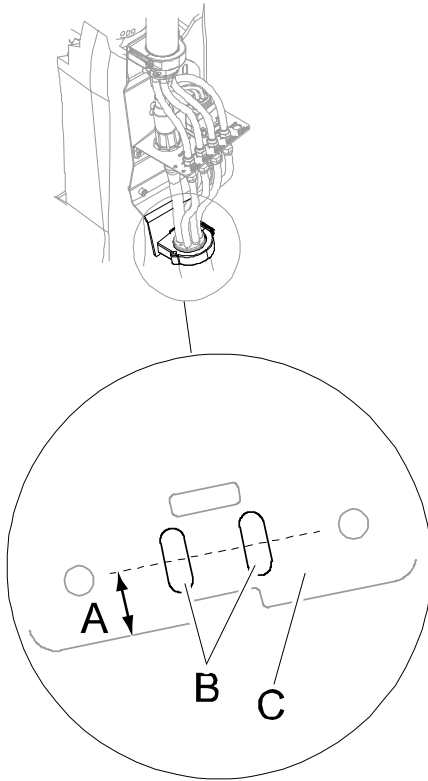
	Action	Note																
5	<p>Fit the gripping clamp to the lower arm plate.</p> <p> Note</p> <p>When fitting the gripping clamp, place the attachment screws in the middle of the oval holes, as shown in the figure to the right.</p>	 <p>xx0500001418</p> <table border="1" data-bbox="1002 683 1439 936"> <tr> <td>A</td> <td>Gripping clamp</td> </tr> <tr> <td>B</td> <td>Screw, M8x25, quality 8.8-A2F (2 pcs)</td> </tr> <tr> <td>C</td> <td>Washer, 2 holes</td> </tr> <tr> <td></td> <td>Washer, (2 pcs)</td> </tr> <tr> <td></td> <td>Locking nuts (2 pcs)</td> </tr> </table>  <p>xx0700000320</p> <table border="1" data-bbox="1002 1780 1439 1944"> <tr> <td>A</td> <td>Measurement 24 mm</td> </tr> <tr> <td>B</td> <td>Oval holes for attachment screws, gripping clamp</td> </tr> <tr> <td>C</td> <td>Lower arm plate</td> </tr> </table>	A	Gripping clamp	B	Screw, M8x25, quality 8.8-A2F (2 pcs)	C	Washer, 2 holes		Washer, (2 pcs)		Locking nuts (2 pcs)	A	Measurement 24 mm	B	Oval holes for attachment screws, gripping clamp	C	Lower arm plate
A	Gripping clamp																	
B	Screw, M8x25, quality 8.8-A2F (2 pcs)																	
C	Washer, 2 holes																	
	Washer, (2 pcs)																	
	Locking nuts (2 pcs)																	
A	Measurement 24 mm																	
B	Oval holes for attachment screws, gripping clamp																	
C	Lower arm plate																	

2 Installation

2.2.6.2 Fitting the cable packages IRBDP MH2 LE and IRBDP SW2 LE

2.2.6.2 Fitting the cable packages IRBDP MH2 LE and IRBDP SW2 LE

Location of lower arm cable package

The lower arm cable package consists of the parts shown in the illustration.

How to fit the attachments for the cable packages IRBDP MH2 LE and IRBDP SW2 LE is described in section [Fitting the attachments of IRBDP MH2 LE and IRBDP SW2 LE on page 69](#).

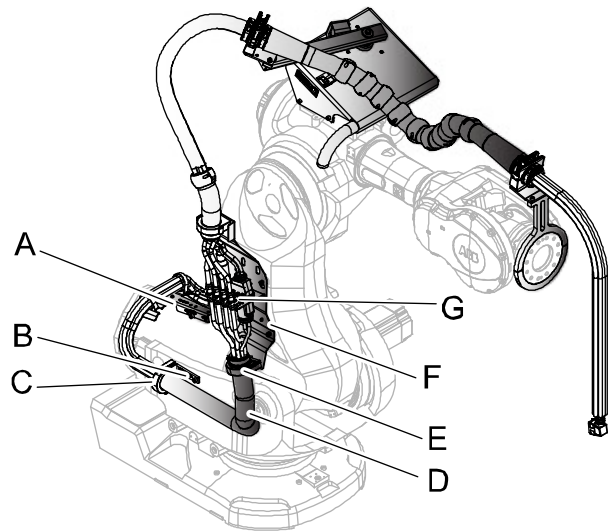
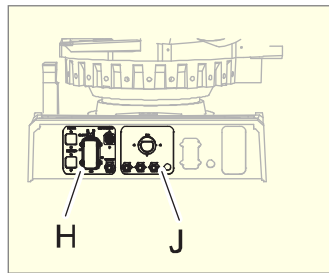
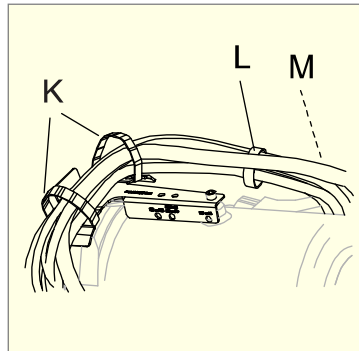

xx0800000151

A	Attachment balancing cylinder
B	Turn plate
C	Gripping clamp
D	Process cable package, lower end
E	Gripping clamp
F	Lower arm plate
G	Connection plate
H	Customer plate
J	Process plate
K	Straps
L	Velcro strap
M	Cable bracket (not visible in this view)

Continues on next page

Required equipment

The following equipment is required for installation of the cable package.

Equipment	Art. no.	Note
Cable package IRBDP MH2 LE	For spare part number see chapter: <ul style="list-style-type: none"> • Spare parts on page 361. 	A number of versions are available.
Cable package IRBDP SW2 LE	For spare part number see chapter: <ul style="list-style-type: none"> • Spare parts on page 361. 	A number of versions are available.
Circuit diagram	3HAC026209-001	

Required tools



Equipment	Article number	Note
Standard toolkit, DressPack	3HAC17290-7	The contents are defined in section Toolkits, DressPack on page 357 .
Other tools and procedures may be required. See references to these procedures in the step-by-step instructions below.		These procedures include references to the tools required.

Required consumables

Consumable	Article number	Note
Locking liquid	3HAB7116-1	Used for locking screws. (Loctite 243)

Procedures

Use this procedure to fit the cable packages IRBDP MH2 LE and SW2 LE. Screws are supplied with the kit.

	Action	Note
1	 DANGER Turn off all: <ul style="list-style-type: none"> • electric power supply • hydraulic pressure supply • air pressure supply to the robot, before entering the robot working area.	
2	 CAUTION The cable package is sensitive to mechanical damage. They must be handled with care, especially the connectors, in order to avoid damaging them.	

Continues on next page

2 Installation

2.2.6.2 Fitting the cable packages IRBDP MH2 LE and IRBDP SW2 LE

Continued

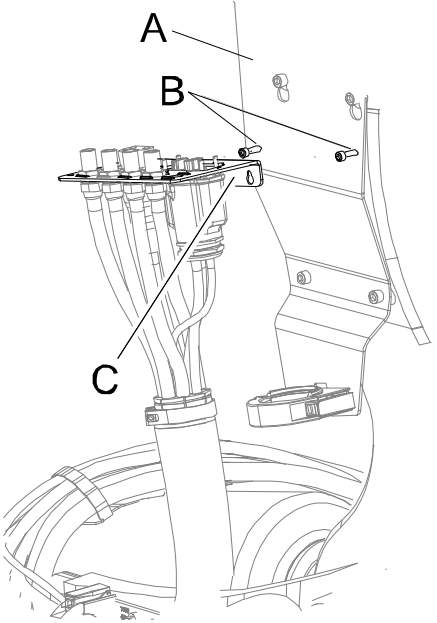
	Action	Note
3	<p>Mount the two <i>attachment screws</i> on the <i>lower arm plate</i>. Use locking liquid on screws.</p> <p>Fit the <i>connection plate</i> on the two screws.</p> <p>The connection plate is pre-mounted on the lower arm cable package.</p>	 <p>xx0500001420</p> <p>Parts:</p> <ul style="list-style-type: none">• A: Lower arm plate• B: Attachment screws M8x12 quality 8.8-A3F (2 pcs)• C: Connection plate

Continues on next page

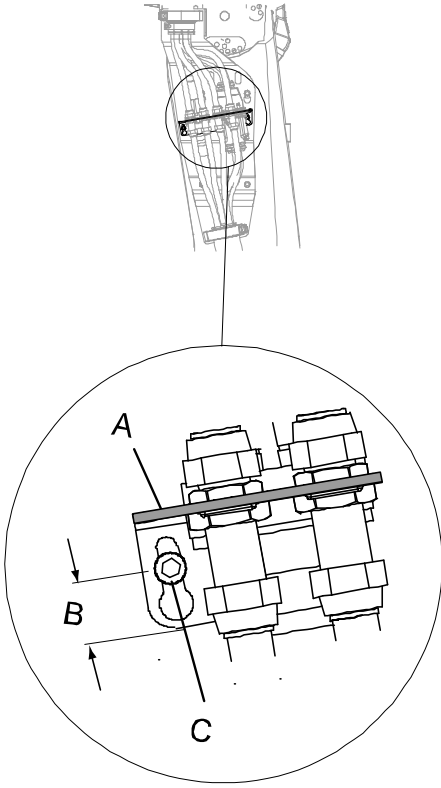
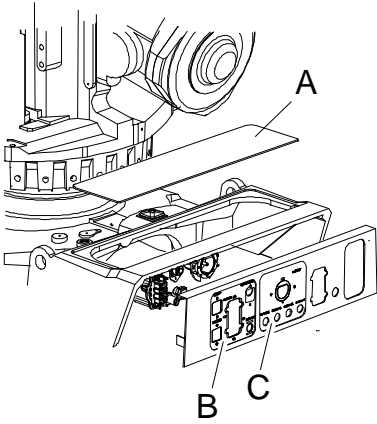
	Action	Note
4	<p>Adjust the <i>connection plate</i> in a way that the center of each <i>attachment screw</i> is placed 27 mm from the lower end of the connection plate.</p> <p>Tighten the screws.</p>	 <p>xx0700000328</p> <p>Parts:</p> <ul style="list-style-type: none"> • A: Connection plate • B: Measurement 27 mm • C: Attachment screw M8x12 quality 8.8-A3F (2 pcs)
5	<p>Remove the <i>top cover plate</i> in the back of the robot base.</p>	 <p>xx0500001422</p> <p>Parts:</p> <ul style="list-style-type: none"> • A: Top cover plate • B: Customer plate • C: Process plate

Continues on next page

2 Installation

2.2.6.2 Fitting the cable packages IRBDP MH2 LE and IRBDP SW2 LE

Continued

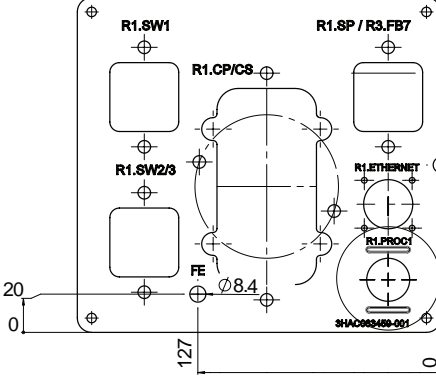
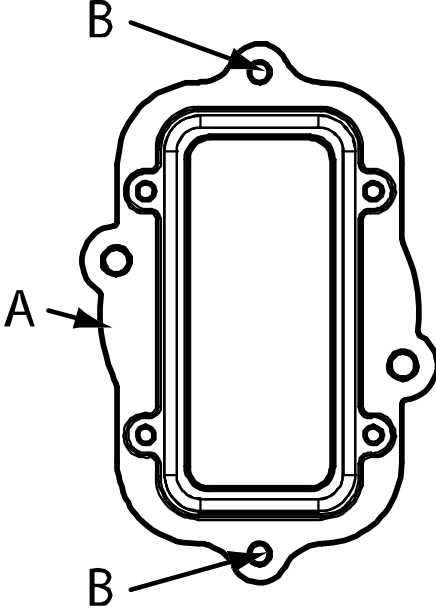
	Action	Note
6	<p>Replace the blank cover plates (covering the holes for customer and process plates), with the <i>customer plate</i> and <i>process plate</i>. Use existing screws. Shown in the figure above.</p>	<p> Note</p> <p>Removal of blank cover plates only needed if the DressPack cable package is fitted for the first time.</p>
7	<p>Only for Paramulti DressPack and for spare part replacement.</p> <p>The Paramulti DressPack spare part includes functional ground. If the installed DressPack has not included functional ground previously, following action needs to be done: Drill an 8.4 mm mm hole in the customer plate according to the figure.</p>	 <p>xx1900001268</p>
8	<p>Fit the <i>adapter complete</i> to the customer plate with the two <i>attachment screws</i>.</p>	 <p>xx0300000195</p> <p>Parts:</p> <ul style="list-style-type: none"> • A: Adapter complete • B: Attachment screws M6x16 quality 8.8-A2F (2 pcs)
9	<p>Run the cables down through the center hole of the gearbox axis 1, in the following order:</p> <ul style="list-style-type: none"> • Signal cables • Hoses, slightly to the right of the signal cables • Check that the signal cables and hoses do not end up between the motor cables • Check that cables and hoses do not cross each other. 	

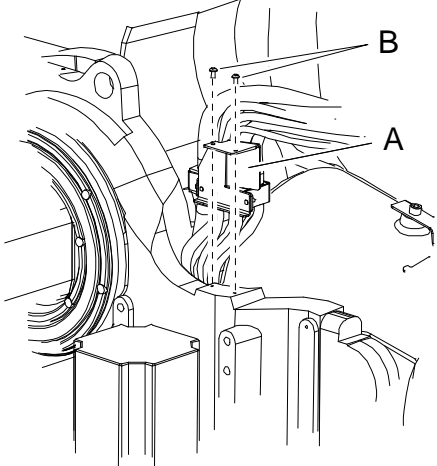

Continues on next page

	Action	Note
10	Strap the cabling with two velcro straps inside axis 1, to avoid cable chafing on the screw.	
11	<p>Attach the <i>cable bracket</i> with the attachment screws M6x16 quality 8.8-A2F (2 pcs). Lock screws with locking liquid.</p>	<p>Art. no. is specified in <i>Required equipment on page 75</i>.</p>  <p>xx0500001421</p> <p>Parts:</p> <ul style="list-style-type: none"> • A: Cable bracket • B: Attachment screws M6x16, quality 8.8-A2F (2 pcs)
12	<p>Spot welding applications only: Run the weld power cable slightly to the right of the signal cables and hoses in order to make it easier to connect the cables in the robot base. Fit the weld power cable to the bracket with its two attachment screws.</p>	<p>Check that the weld power cable does not end up between other cables and hoses!</p>

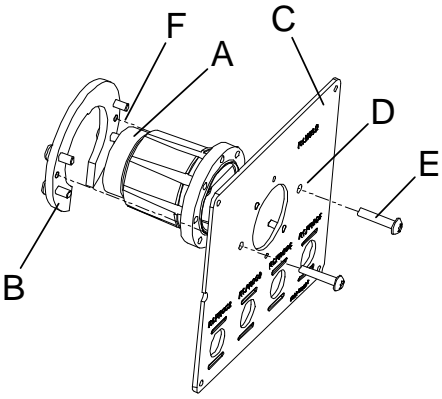

2 Installation

2.2.6.2 Fitting the cable packages IRBDP MH2 LE and IRBDP SW2 LE

Continued

	Action	Note
13	<p>Spot welding applications only: Fit the <i>weld power cable</i> to the rear of the process plate with two attachment screws, using the <i>weld connector bracket</i>. Do not tighten the attachment screws at this point! Screws are supplied with the kit.</p>	 <p>xx0300000196</p> <p>Parts (as seen from above):</p> <ul style="list-style-type: none"> • A: Weld power cable (behind process plate) • B: Weld connector bracket • C: Process plate • D: Screw holes in process plate • E: Attachment screws M6x30 quality 8.8-A2F (2 pcs) • F: Guide pins on weld connector bracket
14	<p>Fit the connectors to the <i>customer</i> and <i>process plates</i>, previously fitted to the connection plate base.</p> <p> CAUTION</p> <p>Do not tighten the brass couplings for water and air with excessive force.</p> <p> CAUTION</p> <p>If the M12 Ethernet connector is not tightened correctly, there is a risk that the connector can loosen and the cable shield gets disconnected, which will require retightening with the correct torque tools.</p> <p>For secure connection, always tighten at the knurled screw with correct torque and by using proper torque tool, e.g. M12 dynamic screwdriver SW15 (09 99 000 0646 (article number at Harting Technology Group)).</p>	<p>Shown in the figure in section Location of lower arm cable package on page 74.</p> <p>Tightening torque:</p> <ul style="list-style-type: none"> • Brass coupling 1/2": 31 Nm. • Stainless steel coupling 1/2": 49 Nm. • Brass coupling 3/8": 17 Nm. • Mixed metals: Use the lower tightening torque value of the two metals. <p>Always apply Molykote P1900 to stainless steel couplings and apply if needed for couplings of mixed metals or brass.</p> <p>Tightening torque, Ethernet M12: 0.6 Nm.</p> <p>Recheck all cables and hoses for straining or twisting. Reroute if required!</p> <p>Screw dimension: M6x20 quality 8.8.A2F (4 pcs to each plate).</p>

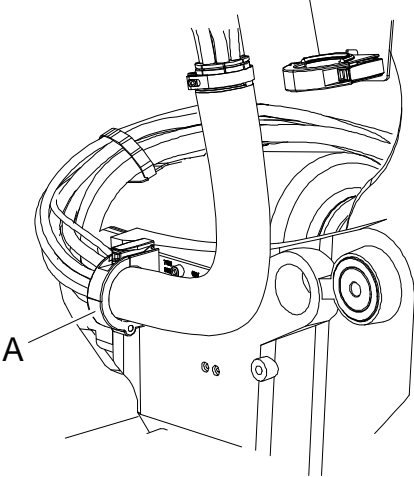
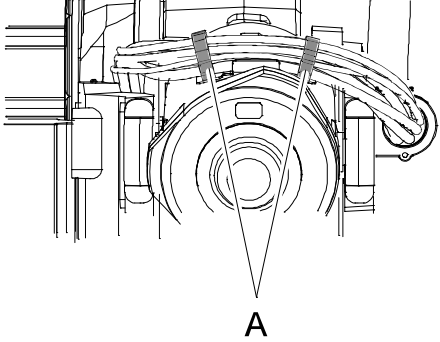
Continues on next page

Action	Note
<p>15</p>  Tip <p>In order to get the weld power cable mounted in the right position on the process plate, first connect the floor weld cable to the weld power cable and use it as a guide.</p> <p>Before tightening the weld power attachment screws, make sure that the cable connector is evenly placed in the hole of the process plate.</p> <p>Tighten the weld power cable attachment screws.</p>	<p>The attachment screws of the weld power cable are shown in the figure above.</p>
<p>16</p> <p>Secure the cable package to the <i>gripping clamp</i> on the frame.</p>	 <p>xx0500001425</p> <p>Parts:</p> <ul style="list-style-type: none"> • A: Gripping clamp
<p>17</p> <p>Secure the hoses and cables to the side bracket, balancing device with the two <i>straps</i>.</p>	 <p>xx0500001424</p> <p>Parts:</p> <ul style="list-style-type: none"> • A: Straps
<p>18</p> <p>Place a <i>velcro strap</i> around the cables and hoses.</p>  Note <p>Do not strap around the weld power cable.</p>	

Continues on next page

2 Installation

2.2.6.2 Fitting the cable packages IRBDP MH2 LE and IRBDP SW2 LE

Continued

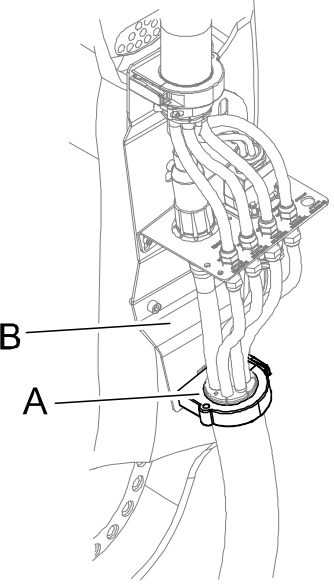
	Action	Note
19	Secure the cable package to the <i>gripping clamp</i> on the <i>lower arm plate</i> .	 <p data-bbox="965 907 1069 929">xx070000333</p> <p data-bbox="965 940 1029 963">Parts:</p> <ul data-bbox="997 974 1244 1030" style="list-style-type: none">• A: Gripping clamp• B: Lower arm plate

2.2.7 Installation of IRBDP MH2 UE and IRBDP SW2 UE

2.2.7.1 Fitting the attachments of IRBDP MH2 UE and IRBDP SW2 UE

**Note**

This section is also valid for how to fit the attachments on the upper end of the cable package IRBDP SW2 CE. Only difference is that the connection plate between upper and lower cable package does not exist since the harness is continuous.

Location of the attachments of IRBDP MH2 UE and IRBDP SW2 UE

The location of the attachments of the cable packages IRBDP MH2 UE and SW2 UE is shown in the figure.

Figure shows IRB 7600.

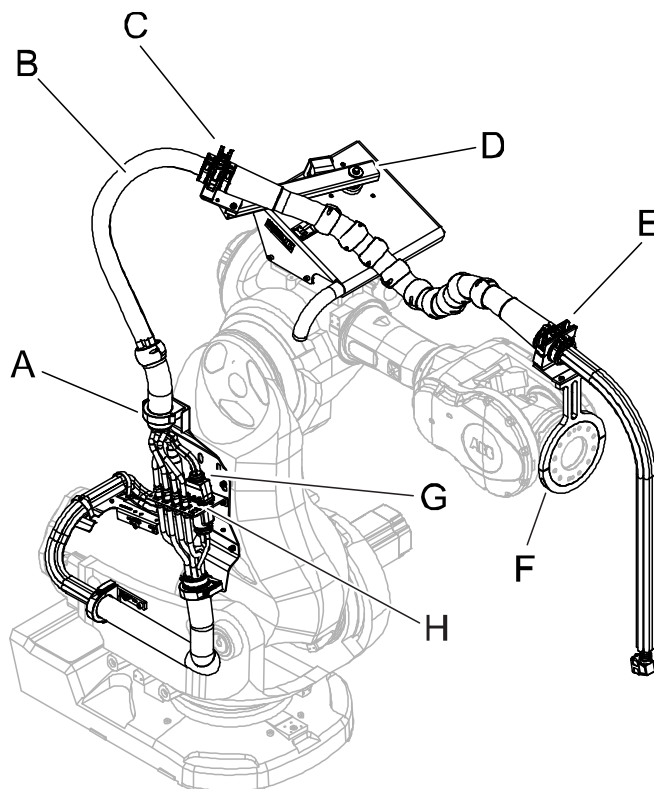

xx080000154

A	Gripping clamp (lower arm plate)
B	Process cable package, upper arm
C	Ball joint housing (tension arm unit)
D	Tension arm unit
E	Ball joint housing (process cable support axis 6)
F	Process cable support axis 6, complete

Continues on next page

2 Installation

2.2.7.1 Fitting the attachments of IRBDP MH2 UE and IRBDP SW2 UE

Continued

G	Lower arm plate
H	Connection plate

Required equipment

The following equipment is required for fitting the cable package attachments.

Equipment	Art. no.	Note
Standard toolkit, DressPack	3HAC17290-7	The contents are defined in section Toolkits, DressPack on page 357 .
Other tools and procedures may be required. See references to these procedures in the step-by-step instructions below.		These procedures include references to the tools required.

Required consumables

Consumable	Article number	Note
Locking liquid	3HAB7116-1	Loctite 243 For locking the gripping clamps.

Procedure

This procedure describes how to install the attachments for the cable packages IRBDP MH2 UE and SW2 UE. The screws are supplied with the kit.

	Action	Note
1	 DANGER Turn off all: <ul style="list-style-type: none">• electric power supply• hydraulic pressure supply• air pressure supply to the robot, before entering the robot working area.	

Continues on next page

2.2.7.1 Fitting the attachments of IRBDP MH2 UE and IRBDP SW2 UE

Continued

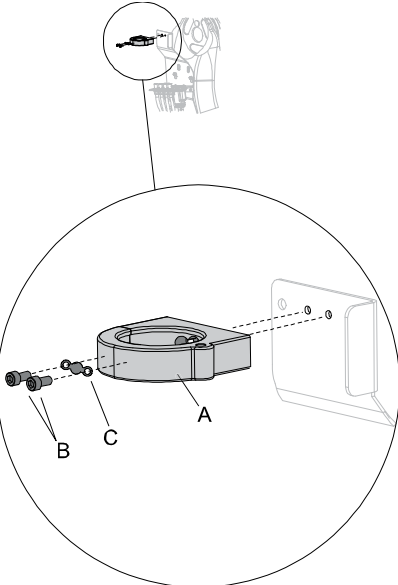
	Action	Note
2	<p>Fit the <i>gripping clamp</i> to the lower arm plate with the two <i>attachment screws</i>.</p> <p>Lock the screws with <i>locking liquid</i>.</p>	<p>Shown in the figure in section, Location of the attachments of IRBDP MH2 UE and IRBDP SW2 UE on page 83</p> <p>Art. no. is specified in section Required equipment on page 84.</p>  <p>xx0500001430</p> <p>Parts:</p> <ul style="list-style-type: none"> • A: Gripping clamp • B: Attachment screws M8x16 quality 8.8-A2F (2 pcs) • C: Washer 2 holes

Continues on next page



2 Installation

2.2.7.1 Fitting the attachments of IRBDP MH2 UE and IRBDP SW2 UE

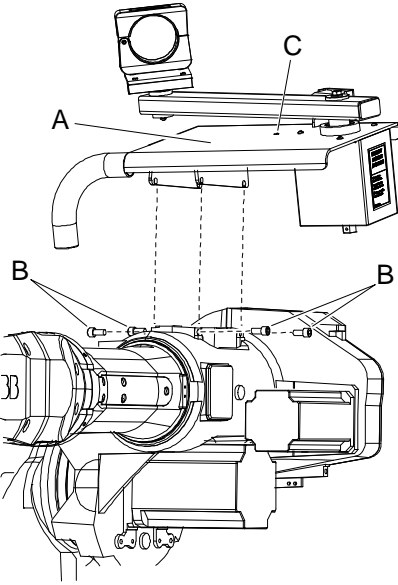
Continued

	Action	Note
3	<p>Fit the tension arm on the arm-house of the robot with the four attachment screws.</p> <p>It is possible to use the Ø10 mm hole with a suitable lifting accessory, to lift the tension arm unit.</p> <p>Lock the screws with <i>locking liquid</i>.</p>	<p>Shown in the figure in section, Location of the attachments of IRBDP MH2 UE and IRBDP SW2 UE on page 83</p> <p>Art. no. is specified in section Required equipment on page 84.</p>  <p>xx0500001433</p> <p>Parts:</p> <ul style="list-style-type: none">• A: Tension arm unit• B: Attachment screws M12x25 quality 8.8-A3F (4 pcs)• C: Ø10 mm hole

Continues on next page

	Action	Note
4	<p>Fit the <i>process cable support, axis 6 complete</i> by performing the following steps:</p> <ul style="list-style-type: none"> • Remove the lower half of the process cable support axis 6 (<i>clamp</i>), by removing its attachment screws. • Fit the parts from "behind" the robot turning disk. • Make sure the process cable support is turned the right way! • Pull the assembly forwards until it is seated against the rear of the turning disk. <p> Note</p> <p>Lock the <i>M10x40 screws</i> with <i>locking liquid</i>. Do not use locking liquid on the <i>M12x80 screws</i> ! Tightening torque M12x80 screws: 70 Nm</p> <p> Note</p> <p>Make sure there are equal gaps between clamp and support of the process cable support axis 6.</p>	

2 Installation

2.2.7.2 Fitting the cable packages IRBDP MH2 UE and IRBDP SW2 UE

2.2.7.2 Fitting the cable packages IRBDP MH2 UE and IRBDP SW2 UE

Location of the cable packages IRBDP MH2 UE and SW2 UE

The cable package consists of the parts shown in the illustration below.

How to fit the attachments for cable packages IRBDP MH2 UE and IRBDP SW2 UE is described in section [Fitting the attachments of IRBDP MH2 UE and IRBDP SW2 UE on page 83](#).

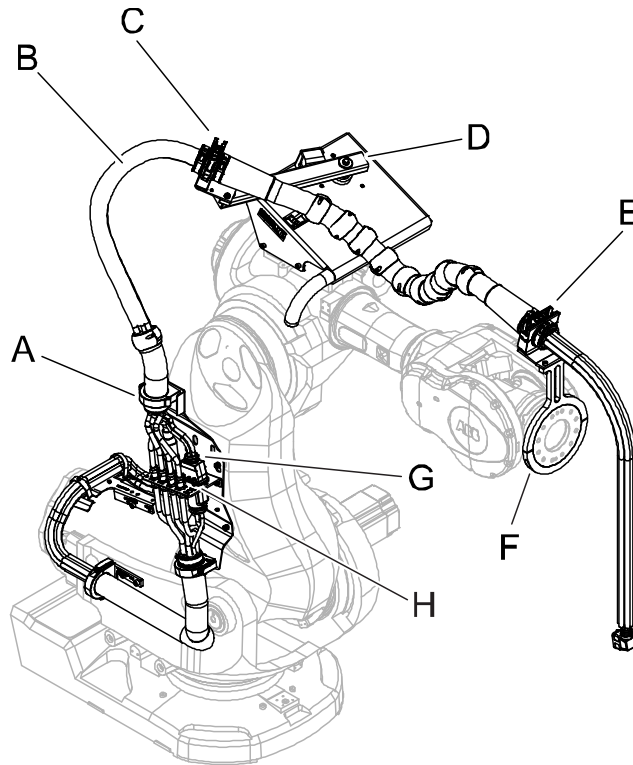

xx0800000154

A	Gripping clamp
B	Process cable package, upper end
C	Ball joint housing
D	Tension arm unit
E	Ball joint housing
F	Process cable support, axis 6
G	Lower arm plate
H	Connection plate

Continues on next page

Required equipment

The following equipment is required for the installation of the cable package.

Equipment	Art. no.	Note
Cable package IRBDP MH2 UE	For spare part number see chapter: <ul style="list-style-type: none"> • Spare parts on page 361. 	A number of versions are available.
Cable package IRBDP SW2 UE	For spare part number see chapter: <ul style="list-style-type: none"> • Spare parts on page 361. 	A number of versions are available.
Circuit diagram	3HAC026209-001	

Required tools



Equipment	Article number	Note
Standard toolkit, DressPack	3HAC17290-7	The contents are defined in section Toolkits, DressPack on page 357 .
Other tools and procedures may be required. See references to these procedures in the step-by-step instructions below.		These procedures include references to the tools required.

Required consumables

Consumable	Article number	Note
Locking liquid	3HAB7116-1	For locking screws (Loctite 243)

Procedure

Use this procedure to fit the cable packages IRBDP MH2 UE and SW2 UE.

	Action	Note
1	 DANGER Turn off all: <ul style="list-style-type: none"> • electric power supply • hydraulic pressure supply • air pressure supply to the robot, before entering the robot working area.	
2	 CAUTION The cable package is sensitive to mechanical damage. They must be handled with care, especially the connectors, in order to avoid damaging them.	

Continues on next page



2 Installation

2.2.7.2 Fitting the cable packages IRBDP MH2 UE and IRBDP SW2 UE

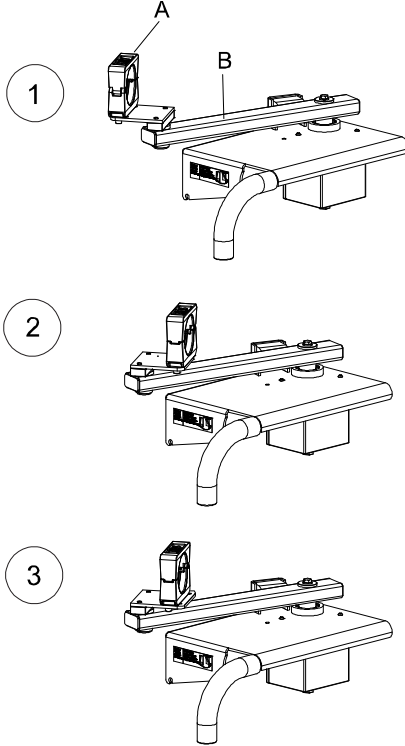
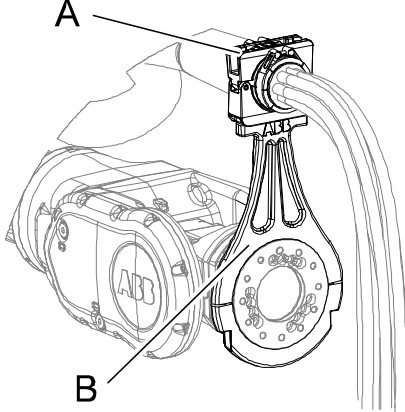
Continued

	Action	Note
3	<p>Straighten the cable package out and place it in the <i>ball joint housing</i> on the <i>tension arm</i>. Secure it.</p> <p>The position of the ball joint housing and the cable package may differ, depending on the robot model. See table below and illustration to the right.</p> <p>Position 1:</p> <ul style="list-style-type: none"> • IRB 6650S - 3.0 • IRB 7600 - 2.3 • IRB 7600 - 2.55 <p>Position 2:</p> <ul style="list-style-type: none"> • IRB 6650S - 3.5 <p>Position 3:</p> <ul style="list-style-type: none"> • IRB 7600 - 2.8 • IRB 7600 - 3.5 	 <p>xx0500001578</p>
4	<p>Place the front end of the cable package in the <i>ball joint housing</i> on the <i>process cable support axis 6, complete</i>. Secure it.</p>	 <p>xx0700000336</p> <p>Parts:</p> <ul style="list-style-type: none"> • A: Ball joint housing • B: Process cable support, axis 6 complete

Continues on next page

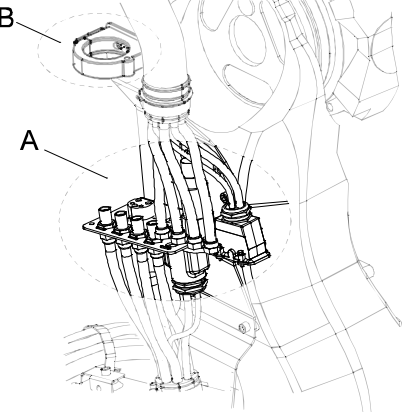
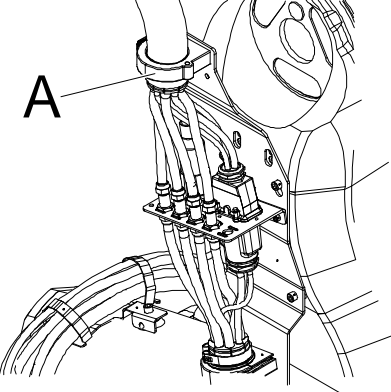
	Action	Note
5	<p>Connect all cable and hoses to the <i>lower arm plate</i> in the following order:</p> <ul style="list-style-type: none"> • Fit the weld connector • Fit the cable package in the gripping clamp • Tighten the weld connector • Fit and tighten the cable connectors • Fit and tighten the hose connectors <p> CAUTION</p> <p>Do not tighten the brass couplings for water and air with excessive force.</p> <p> Note</p> <p>Do not secure the cable package in the <i>gripping clamp</i> on the <i>lower arm plate</i>, until cables and hoses are connected.</p> <p> CAUTION</p> <p>If the M12 Ethernet connector is not tightened correctly, there is a risk that the connector can loosen and the cable shield gets disconnected, which will require retightening with the correct torque tools.</p> <p>For secure connection, always tighten at the knurled screw with correct torque and by using proper torque tool, e.g. M12 dynamometric screwdriver SW15 (09 99 000 0646 (article number at Harting Technology Group)).</p>	<p>Tightening torque:</p> <ul style="list-style-type: none"> • Brass coupling 1/2": 31 Nm. • Stainless steel coupling 1/2": 49 Nm. • Brass coupling 3/8": 17 Nm. • Mixed metals: Use the lower tightening torque value of the two metals. <p>Always apply Molykote P1900 to stainless steel couplings and apply if needed for couplings of mixed metals or brass.</p> <p>Tightening torque, Ethernet M12: 0.6 Nm.</p>  <p>xx0500001439</p> <p>Parts:</p> <ul style="list-style-type: none"> • A: Cable and hose connections on the lower arm plate • B: Gripping clamp
6	<p>Secure the cable package with the gripping clamp on the lower arm plate.</p>	 <p>xx0500001440</p> <p>Parts:</p> <ul style="list-style-type: none"> • A: Gripping clamp

2 Installation

2.2.7.3 Fitting the cable package IRBDP SW2 CE

2.2.7.3 Fitting the cable package IRBDP SW2 CE

Location of cable package - IRBDP SW2 CE

The cable package, IRBDP SW2 CE consists of the parts shown in the illustration below.

How to fit the attachments for the process cable package IRBDP SW2 CE is detailed in sections:

- [Fitting the attachments of IRBDP MH2 LE and IRBDP SW2 LE on page 69](#)
- [Fitting the attachments of IRBDP MH2 UE and IRBDP SW2 UE on page 83](#)

Continues on next page

Figure shows IRB 6600.

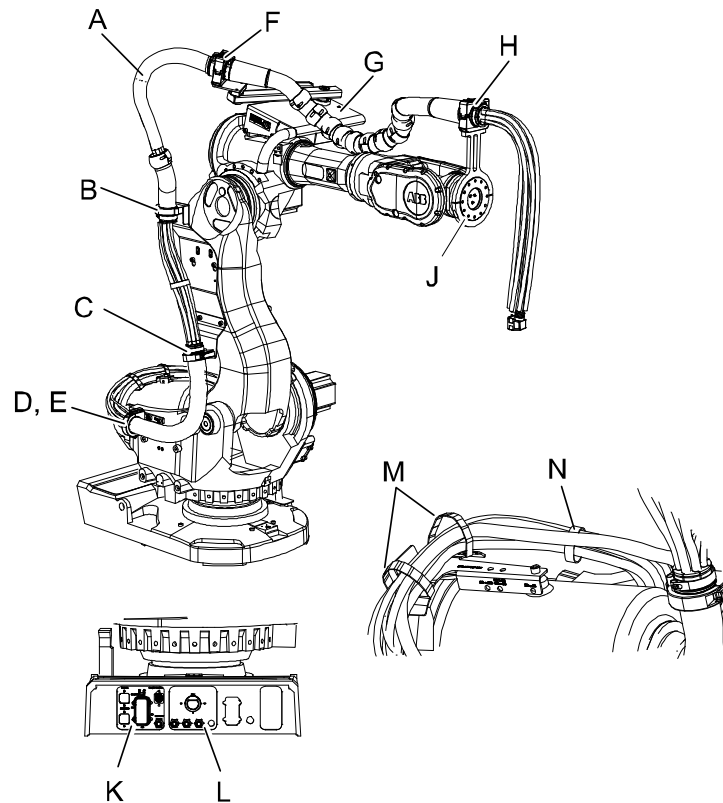

xx0500001445

A	Process cable package
B	Upper gripping clamp (lower arm plate)
C	Lower gripping clamp (lower arm plate)
D	Gripping clamp, base frame
E	Turn plate
F	Ball joint housing (tension arm unit)
G	Tension arm unit
H	Ball joint housing (process cable support axis 6)
J	Process cable support axis 6, complete
K	Customer plate
L	Process plate
M	Attachment balancing device with straps
N	Velcro strap

Continues on next page

2 Installation

2.2.7.3 Fitting the cable package IRBDP SW2 CE

Continued

Required equipment

The following equipment are required for installation of the cable package IRBDP SW2 CE.

Equipment	Art. no.	Note
Cable package IRBDP SW2 CE	For spare part number see chapter: <ul style="list-style-type: none">• Spare parts on page 361.	A number of versions are available.
Circuit diagram	3HAC026209-001	DressPack

Required tools



Equipment	Article number	Note
Standard toolkit, DressPack	3HAC17290-7	The contents are defined in section Toolkits, DressPack on page 357 .
Other tools and procedures may be required. See references to these procedures in the step-by-step instructions below.		These procedures include references to the tools required.

Required consumables

Consumable	Article number	Note
Locking liquid	3HAB7116-1	Loctite 243 For locking the gripping clamps.

Procedure

Use this procedure to fit the cable package IRBDP SW2 CE.

	Action	Note
1	 DANGER Turn off all: <ul style="list-style-type: none">• electric power supply• hydraulic pressure supply• air pressure supply to the robot, before entering the robot working area.	
2	 CAUTION The cable package is sensitive to mechanical damage. They must be handled with care, especially the connectors, in order to avoid damaging them.	

Continues on next page

	Action	Note
3	<p>Straighten the cable package out and place it in the <i>ball joint housing</i> on the <i>tension arm unit</i>. Secure it.</p> <p>The position of the ball joint housing and the tension arm shall be as shown in the figure, in order to get the correct position of the cable package.</p> <p>Position 1:</p> <ul style="list-style-type: none"> • IRB 6650S - 3.0 • IRB 7600 - 2.3 • IRB 7600 - 2.55 <p>Position 2:</p> <ul style="list-style-type: none"> • IRB 6650S - 3.5 <p>Position 3:</p> <ul style="list-style-type: none"> • IRB 7600 - 2.8 • IRB 7600 - 3.5 	<p>xx0500001578</p> <p>Parts:</p> <ul style="list-style-type: none"> • A: Ball joint housing • B: Tension arm

Continues on next page

2 Installation

2.2.7.3 Fitting the cable package IRBDP SW2 CE

Continued

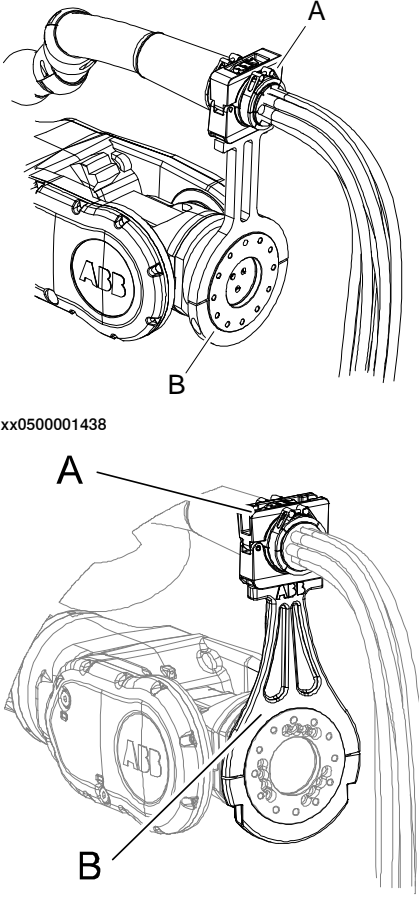
	Action	Note
4	Place the front end of the cable package in the <i>ball joint housing</i> on the <i>process cable support axis 6 complete</i> , and secure it.	<p>Shown in the figure below: This figure shows IRB 7600.</p>  <p>xx0500001438</p> <p>xx0700000336</p> <p>Parts:</p> <ul style="list-style-type: none">• A: Ball joint housing• B: Process cable support, axis 6 complete

Continues on next page

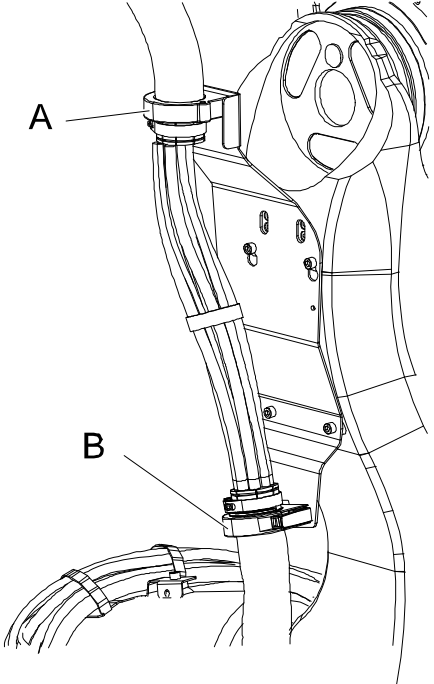
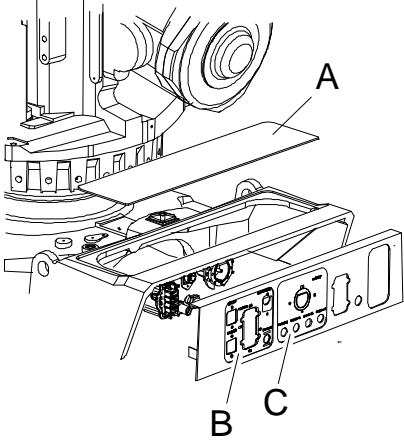
	Action	Note
5	Secure the cable package to the <i>upper</i> and <i>lower gripping clamps</i> on the lower arm plate.	<p>Shown in the figure below.</p>  <p>xx0500001483</p> <p>Parts:</p> <ul style="list-style-type: none"> • A: Upper gripping clamp • B: Lower gripping clamp
6	Remove the <i>top cover plate</i> in the back of the robot base.	 <p>xx0500001422</p> <p>Parts:</p> <ul style="list-style-type: none"> • A: Top cover plate • B: Customer plate • C: Process plate
7	Remove the blank cover plates and replace them with the <i>process-</i> and <i>customer plates</i> . Reuse existing screws.	

Continues on next page



2 Installation

2.2.7.3 Fitting the cable package IRBDP SW2 CE

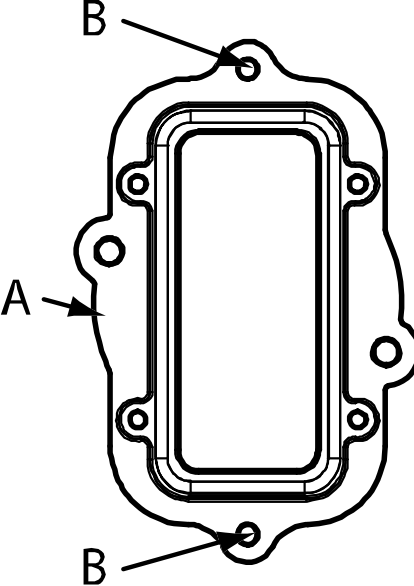
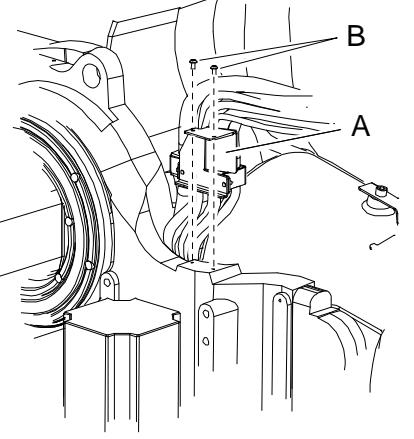
Continued

	Action	Note
8	<p>Fit the <i>adapter complete</i> to the customer plate with its two <i>attachment screws</i>. Screws are supplied with the kit.</p>	 <p>xx0300000195</p> <p>Parts:</p> <ul style="list-style-type: none"> A: Adapter complete B: Attachment screws M6x16 quality 8.8-A2F (2 pcs)
9	<p>Run the cables down through the center hole of gearbox axis 1 in the following order:</p> <ul style="list-style-type: none"> Signal cable Hoses, slightly to the right of the signal cable <p>Check:</p> <ul style="list-style-type: none"> Check that signal cable and hoses do not end up between the motor cables Check that cables and hoses do not cross each other. 	 <p>xx0500001421</p> <p>Parts:</p> <ul style="list-style-type: none"> A: Cable and hose clamp B: Attachment screws (2 pcs)
10	<p>Attach the <i>cable and hose clamp</i> with the <i>attachment screws</i> M6x16 quality 8.8-A2F (2 pcs). Lock the screws with <i>locking liquid</i>. Screws are supplied with the kit.</p>	<p>Art. no. is specified in section Required equipment on page 94.</p>

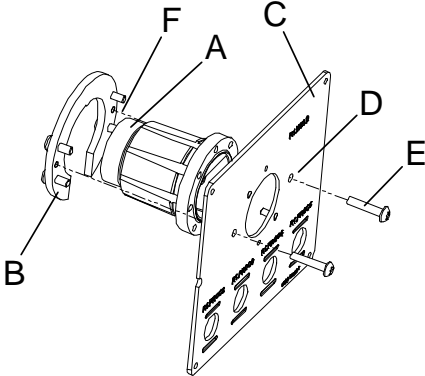
Continues on next page

	Action	Note
11	<p>Spot welding applications only: Run the <i>weld power cable</i>, slightly to the right of the signal cable and hoses in order to facilitate the connecting of cables in the robot base. Fit the weld power cable to the cable holder bracket axis 1 with its two locking nuts M6.</p>	<p>Check that the weld power cable do not end up between other cables and hoses.</p>
12	<p>Spot welding applications only: Fit the weld power cable to the rear of the <i>process plate</i>, with two <i>attachment screws</i> using the <i>weld connector bracket</i>. Do not tighten the attachment screws at this point. Screws are supplied with the kit.</p>	 <p>xx0300000196</p> <p>Parts (as seen from above):</p> <ul style="list-style-type: none"> • A: Weld power cable (behind process plate) • B: Weld connector bracket • C: Process plate • D: Screw holes in process plate • E: Attachment screws M6x30 quality 8.8-A2F (2 pcs) • F: Guide pins on weld connector bracket
13	<p>Fit the connectors to the <i>customer plate</i> and <i>process plate</i> previously fitted to the <i>connection plate, base</i>. Screws are supplied with the kit.</p> <p> CAUTION</p> <p>Do not tighten the brass couplings for water and air with excessive force.</p> <p> CAUTION</p> <p>If the M12 Ethernet connector is not tightened correctly, there is a risk that the connector can loosen and the cable shield gets disconnected, which will require retightening with the correct torque tools.</p> <p>For secure connection, always tighten at the knurled screw with correct torque and by using proper torque tool, e.g. M12 dynamometric screwdriver SW15 (09 99 000 0646 (article number at Harting Technology Group)).</p>	<p>Tightening torque:</p> <ul style="list-style-type: none"> • Brass coupling 1/2": 31 Nm. • Stainless steel coupling 1/2": 49 Nm. • Brass coupling 3/8": 17 Nm. • Mixed metals: Use the lower tightening torque value of the two metals. <p>Always apply Molykote P1900 to stainless steel couplings and apply if needed for couplings of mixed metals or brass.</p> <p>Tightening torque, Ethernet M12: 0.6 Nm.</p> <p>Shown in the figure in section Location of cable package - IRBDP SW2 CE on page 92.</p> <p>Recheck all cables and hoses for straining or twisting. Reroute if required! Screw dimension: M6x20</p>

Continues on next page

2 Installation

2.2.7.3 Fitting the cable package IRBDP SW2 CE

Continued

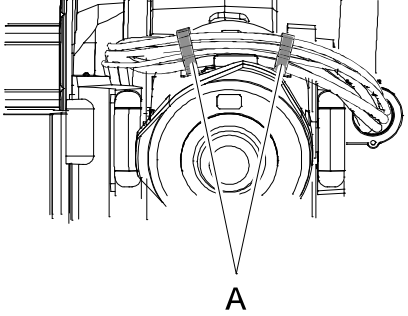
	Action	Note
14	<p> Tip</p> <p>In order to get the weld power cable fitted in the right position on the plate customer, first connect the floor weld cable to the weld power cable and use it as a guide.</p> <p>Before tightening the weld power attachment screws, make sure that the cable connector is evenly positioned in the hole of the process plate.</p> <p>Tighten the weld power cable attachment screws.</p>	<p>The weld power attachments screws are shown in figure above!</p>
15	<p>Secure the hoses and cables to the side bracket, balancing device with the two <i>straps</i>.</p>	 <p>xx0500001424</p> <p>Parts:</p> <ul style="list-style-type: none">• A: Straps

2.2.8 Installation of IRBDP SW5 CE, DressPack basic

2.2.8.1 Fitting the attachments of IRBDP SW5 CE (DressPack Basic)

Location of the attachments

The location of the attachments of IRBDP SW5 CE (DressPack Basic) is shown in the figure.

Figure shows IRB 7600

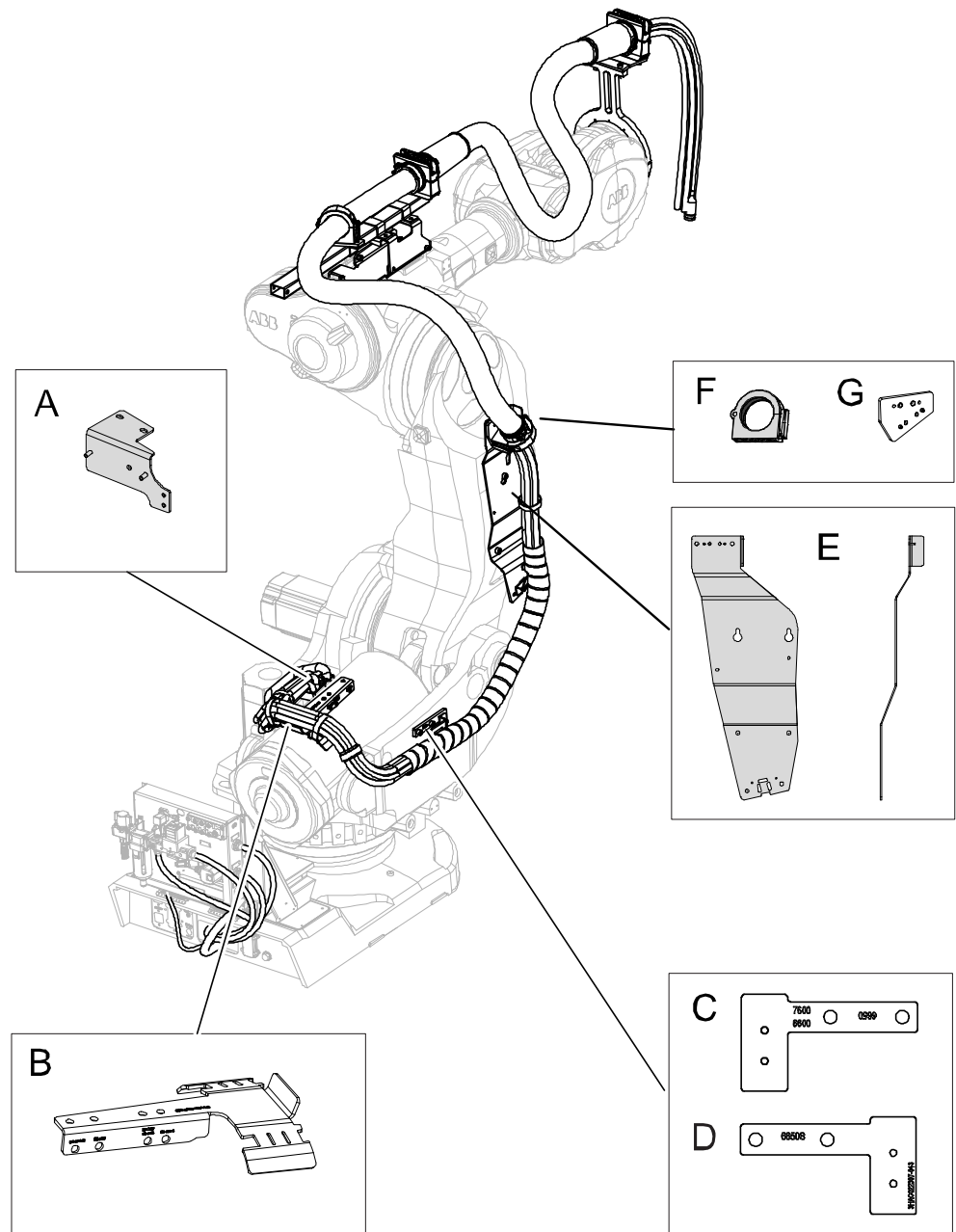

xx0800000179

A	Bracket
---	---------

Continues on next page

2 Installation

2.2.8.1 Fitting the attachments of IRBDP SW5 CE (DressPack Basic)

Continued

B	Attachment balancing cylinder
C	Turn plate positioned for robot version IRB 7600 + Spiral hose clamp
D	Turn plate positioned for robot version IRB 6650S + Spiral hose clamp
E	Lower arm plate + Spiral hose clamp fitted at lower holes on plate
F	Gripping clamp
G	Angled clamp bracket

Location of upper attachments

The location of the upper attachments of the cable package IRBDP SW5 CE (DressPack Basic) are shown in the figure below.

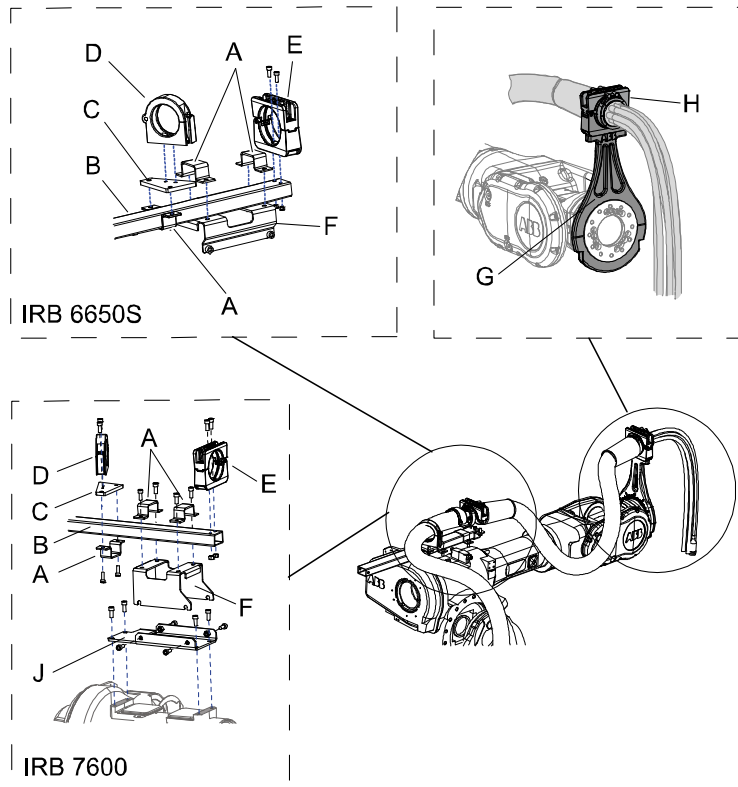

xx0800000074

A	Bracket (3 pcs)
B	Adjustable bracket
C	Angled clamp bracket
D	Gripping clamp
E	Ball joint housing (adjustable bracket)
F	Axis 3 bracket
G	Process cable support axis 6
H	Ball joint housing (harness support axis 6)
J	Adapter plate (only applicable to IRB 7600)

Continues on next page

Required equipment

Equipment	Part. no.	Note
Standard toolkit DressPack	3HAC17290-7	The contents are defined in section Toolkits, DressPack on page 357 .
Other tools and procedures may be required. See references to these procedures in the step-by-step instructions below.		These procedures include references to the tools required.

Required consumables

Consumable	Article number	Note
Locking liquid	3HAB7116-1	Loctite 243 For locking screws.

Fitting cable attachments - lower end

This procedure describes how to install the attachments at the lower end of the cable package (DressPack basic).

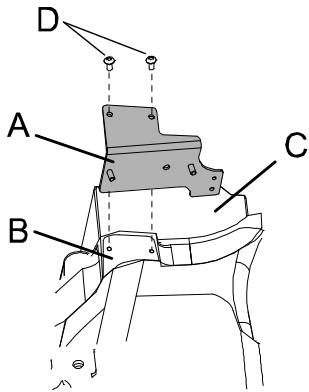

Action	Note
<p>1</p>  <p>DANGER</p> <p>Turn off all:</p> <ul style="list-style-type: none"> • electric power supply • hydraulic pressure supply • air pressure supply <p>to the robot, before entering the robot working area.</p>	
<p>2</p> <p>Fit the <i>bracket</i> on the frame with its attachment screws.</p> <p>Lock screws with <i>locking liquid</i>.</p>	 <p>xx0800000097</p> <p>Parts:</p> <ul style="list-style-type: none"> • A: Bracket • B: Frame • C: Motor axis 1 • D: Attachment screws M6x16 quality 8.8-A2F (2 pcs)

Continues on next page

2 Installation

2.2.8.1 Fitting the attachments of IRBDP SW5 CE (DressPack Basic)

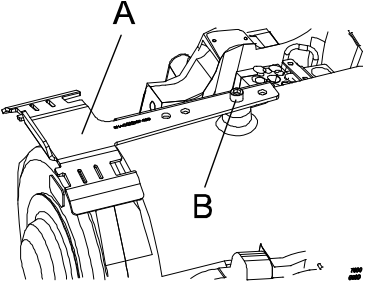
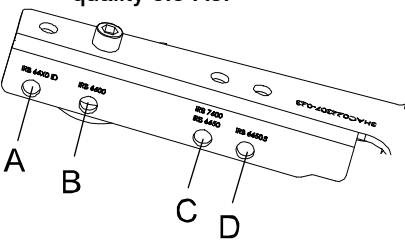
Continued

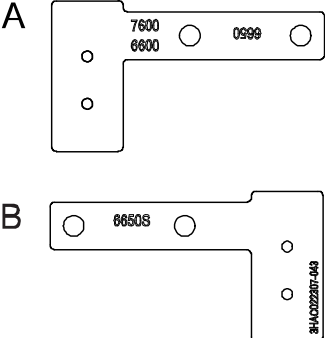
	Action	Note
3	<p>Fit the <i>attachment balancing cylinder</i> with its attachment screw. Lock screw with <i>locking liquid</i>. The screws are supplied with the kit.</p> <p> Note</p> <p>Fit the attachment balancing cylinder in the correct hole depending on robot model and variant. See markings!</p>	 <p>xx0800000098</p> <p>Parts:</p> <ul style="list-style-type: none"> • A: Attachment balancing cylinder • B: Attachment screw M12x35 quality 8.8-A3F  <p>xx0800000099</p> <p>Markings for fitting position:</p> <ul style="list-style-type: none"> • A: IRB 66X01D • B: IRB 6600 • C: IRB 6650 & IRB 7600 • D: IRB 6650S
4	<p>Fit the <i>turn plate</i> to the frame with its attachment screws. Also fit the <i>spiral hose clamp</i> on the turn plate.</p> <p> Note</p> <p>Fit the turn plate correctly depending on robot model and variant.</p>	<p>Shown in the figure Location of the attachments on page 101.</p>  <p>xx0800000180</p> <p>Position and making:</p> <ul style="list-style-type: none"> • A: IRB 7600 • B: IRB 6650S
5	<p>Fit the <i>spiral hose clamp</i> on the bottom lower bracket.</p>	<p>Shown in the figure Location of the attachments on page 101.</p>

Continues on next page

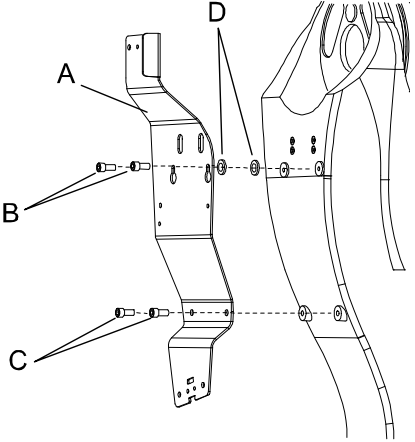
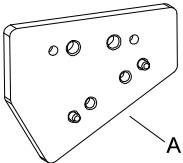
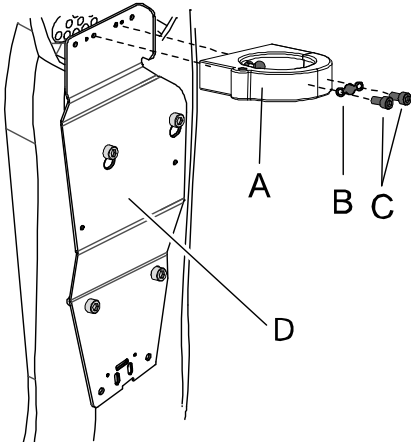
	Action	Note
6	<p>Fit the <i>lower arm plate</i> to the lower arm with its <i>attachment screws</i>.</p> <p>Depending on the robot model, use washers between lower arm plate and robot.</p> <ul style="list-style-type: none"> • IRB 7600: two washers • IRB 6650S: washers not needed. <p>Lock screws with <i>locking liquid</i>.</p>	 <p>xx0500001419</p> <p>Parts:</p> <ul style="list-style-type: none"> • A: Lower arm plate • B: Attachment screws M12x35 quality 8.8-A3F (2 pcs) • C: Attachment screws M12x25 quality 8.8-A3F (2 pcs) • D: (IRB 7600) Washer (2 pcs)
7	<p>Only applicable to IRB 7600.</p> <p>Fit the <i>angled clamp bracket</i> on the lower arm plate with its attachment screws.</p>	 <p>xx0800000186</p> <p>Part:</p> <ul style="list-style-type: none"> • Angled clamp bracket
8	<p>IRB 6650S: Fit the <i>gripping clamp</i> on the <i>lower arm plate</i> with:</p> <ul style="list-style-type: none"> • attachment screws M8x25 quality 8.8-A2F (2 pcs) • washer 2 holes <p>IRB 7600: Fit the <i>gripping clamp</i> on the <i>angled clamp bracket</i> (fitted on the <i>lower arm plate</i>).</p> <ul style="list-style-type: none"> • attachment screws M8x25 quality 8.8-A2F (2 pcs) • washer 2 holes <p>Lock screws with <i>locking liquid</i>.</p>	 <p>xx0800000073</p> <p>Parts:</p> <ul style="list-style-type: none"> • A: Gripping clamp • B: Washer 2 holes • C: Attachment screws M8x25 quality 8.8-A2F (2 pcs) • D: Lower arm plate

Continues on next page

2 Installation

2.2.8.1 Fitting the attachments of IRBDP SW5 CE (DressPack Basic)



Continued

Fitting cable attachments - upper end

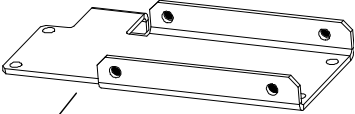
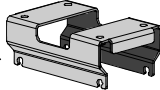
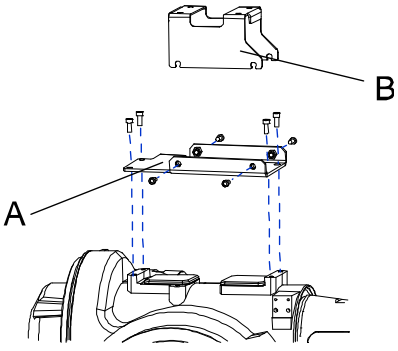
This procedure describes how to install the attachments at the upper end of the cable package (DressPack basic).

	Action	Note
1	 <p>DANGER</p> <p>Turn off all:</p> <ul style="list-style-type: none"> • electric power supply • hydraulic pressure supply • air pressure supply <p>to the robot, before entering the robot working area.</p>	
2	<p>Only applicable to IRB 7600.</p> <p>Fit the <i>adapter plate</i> (if not already fitted) to the arm house with its attachment screws.</p>	 <p>A xx0800000181</p> <p>Part:</p> <ul style="list-style-type: none"> • A: Adapter plate
3	<p>Fit the <i>axis 3 bracket</i> to:</p> <p>IRB 6650S</p> <ul style="list-style-type: none"> • the armhouse with its attachment screws. <p>IRB 7600</p> <ul style="list-style-type: none"> • the <i>adapter plate</i> with its attachment screws. <p>Lock screws with <i>locking liquid</i>.</p>	<p>Locking liquid is specified in Required equipment on page 103.</p> <p>IRB 6650S</p>  <p>A xx0800000075</p> <p>Parts:</p> <ul style="list-style-type: none"> • A: Axis 3 bracket <p>IRB 7600</p>  <p>A</p> <p>B</p> <p>xx0800000182</p> <p>Parts:</p> <ul style="list-style-type: none"> • A: Adapter plate • B: Axis 3 bracket, IRB 7600

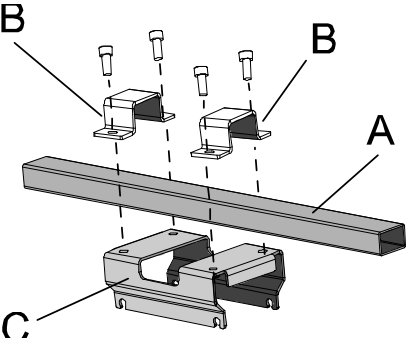
Continues on next page

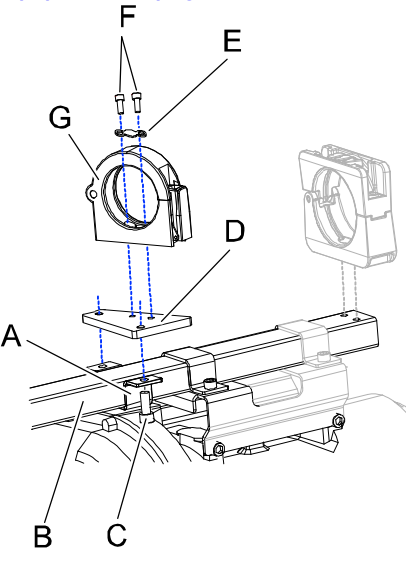
	Action	Note
4	<p>Fit the <i>adjustable bracket</i> to the <i>axis 3 bracket</i> with its <i>brackets</i> and attachment screws. Lock screws with <i>locking liquid</i>.</p>	<p>Locking liquid is specified in Required equipment on page 103.</p>  <p>xx080000076</p> <p>Parts:</p> <ul style="list-style-type: none"> • A: Adjustable bracket • B: Bracket • C: Axis 3 bracket
5	<p>Fit the <i>gripping clamp</i> to the <i>angled clamp bracket</i> with its <i>attachment screws</i> and <i>washer 2 holes</i>. Lock screws with <i>locking liquid</i>.</p> <p>Then fit the angled clamp bracket with the gripping clamp already fitted on the <i>adjustable bracket</i> with the <i>bracket</i> and its <i>attachment screws</i>.</p> <p> Note</p> <p>Do not secure the attachment screws (M10x25) at this point! It must still be possible to move the gripping clamp back and forth on the adjustable bracket. Adjustment of the gripping clamp is detailed in section Adjustment of the cable package - IRBDP SW5 CE (DressPack Basic) on page 176.</p>	<p>Locking liquid is specified in Required equipment on page 103.</p>  <p>xx0800000107</p> <p>Parts:</p> <ul style="list-style-type: none"> • A: Bracket • B: Adjustable bracket • C: Attachment screw M10x25 quality 8.8-A3F (2 pcs) • D: Angled clamp bracket • E: Washer 2 holes • F: Attachment screw M8x16 quality 8.8_A2F (2 pcs) • G: Gripping clamp

Continues on next page

2 Installation

2.2.8.1 Fitting the attachments of IRBDP SW5 CE (DressPack Basic)

Continued

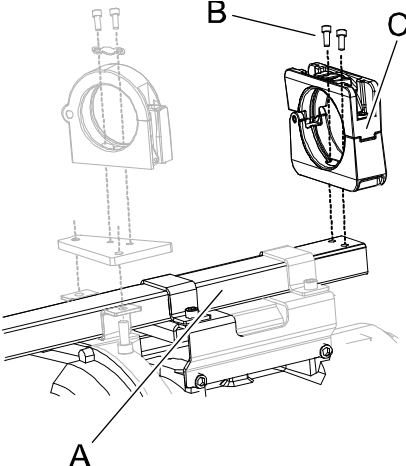
	Action	Note
6	<p>Fit the <i>ball joint housing</i> to the <i>adjustable bracket</i> with the <i>bracket</i> and its <i>attachment screws</i> and <i>washer 2 holes</i>.</p> <p> Note</p> <p>Do not secure the attachment screws (M10x25) at this point! It must still be possible to move the gripping clamp back and forth on the adjustable bracket. Adjustment of the gripping clamp is detailed in section Adjustment of the cable package - IRBDP SW5 CE (DressPack Basic) on page 176.</p>	 <p>xx0800000108</p> <p>Parts:</p> <ul style="list-style-type: none"> • A: Adjustable bracket • B: Attachment screw M10x25 quality 8.8-A3F (2 pcs) • C: Ball joint housing
7	<p>Fit the <i>harness support axis 6</i> to the turning disk with its attachment screws. Lock screws with <i>locking liquid</i>.</p>	<p>Shown in the figure Location of upper attachments on page 102. Locking liquid is specified in Required equipment on page 103.</p>
8	<p>Fit the <i>ball joint housing</i> the harness support axis 6 with its attachment screws. Lock screws with <i>locking liquid</i>.</p>	<p>Shown in the figure Location of upper attachments on page 102. Locking liquid is specified in Required equipment on page 103.</p>

2.2.8.2 Fitting the cable package IRBDP SW5 CE (DressPack Basic)

Location of the cable package

The location of the cable package IRBDP SW5 CE (DressPack Basic) is shown in the figure below.

How to fit the attachments for the process cable package IRBDP SW5 CE is detailed in section [Fitting the attachments of IRBDP SW5 CE \(DressPack Basic\) on page 101](#).

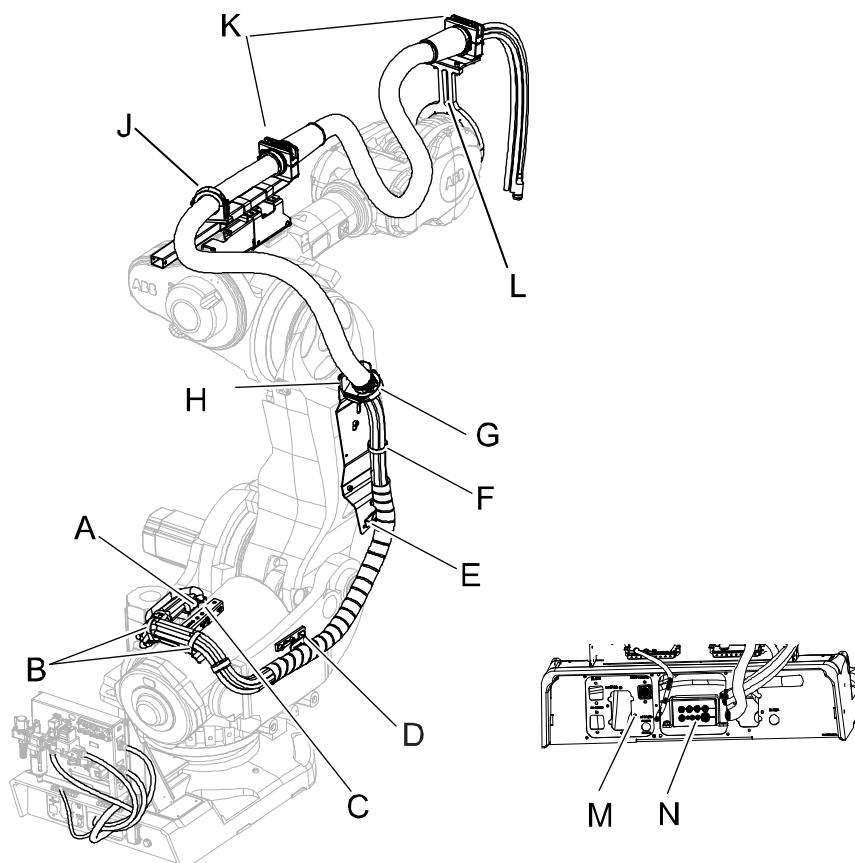

xx0800000184

A	Cable and hose clamp
B	Velcro straps
C	Attachment balancing cylinder
D	Spiral hose clamp (turn plate)
E	Spiral hose clamp (lower arm plate)
F	Velcro strap
G	Gripping clamp (lower arm plate)
H	Angled clamp bracket
J	Gripping clamp (adjustable bracket)
K	Ball joint housing
L	Process cable support axis 6
M	Customer plate

Continues on next page

2 Installation

2.2.8.2 Fitting the cable package IRBDP SW5 CE (DressPack Basic)

Continued

N	Clamp holder with plastic clamp
---	---------------------------------

Required equipment



Equipment	Art. no.	Note
Cable package IRBDP SW5 CE (DressPack Basic)	For spare part number see chapter: <ul style="list-style-type: none"><i>Spare parts on page 361.</i>	A number of variants are available.

Required tools

Equipment	Article number	Note
Standard toolkit, DressPack	3HAC17290-7	The contents are defined in section <i>Toolkits, DressPack on page 357.</i>
Other tools and procedures may be required. See references to these procedures in the step-by-step instructions below.		These procedures include references to the tools required.

Procedure

Use this procedure to fit the cable package IRBDP SW5 CE (DressPack Basic).

	Action	Note
1	 DANGER Turn off all: <ul style="list-style-type: none">• electric power supply• hydraulic pressure supply• air pressure supply to the robot, before entering the robot working area.	
2	 CAUTION The cable package is sensitive to mechanical damage. They must be handled with care, especially the connectors, in order to avoid damaging them.	

Continues on next page

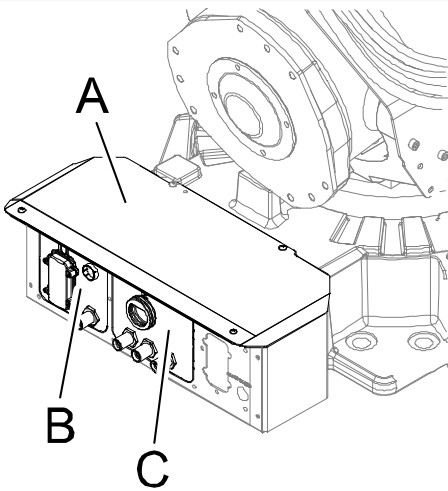

	Action	Note
3	Remove the <i>rear top cover plate</i> in the back of the robot base.	 <p>xx0700000329</p> <p>Parts:</p> <ul style="list-style-type: none"> A: Rear top cover plate
4	Remove the blank cover plates and replace them with the <i>process-</i> and <i>customer plates</i> .	
5	Run the cables and hoses down through the center hole of gearbox axis 1 in the following order: <ul style="list-style-type: none"> Signal cable Hoses, slightly to the right of the signal cable Check that signal cable and hoses do not end up between the motor cables Check that cables and hoses do not cross each other. 	
6	Fit the process cable package to the bracket with the <i>cable and hose clamp</i> .	Shown in the figure Location of the cable package on page 109 .

Continues on next page

2 Installation

2.2.8.2 Fitting the cable package IRBDP SW5 CE (DressPack Basic)

Continued

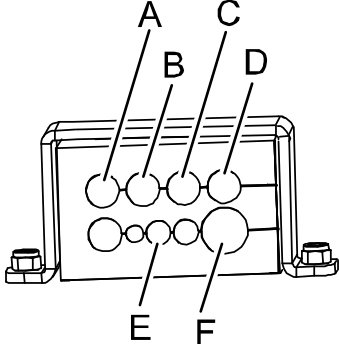
	Action	Note
7	<p>Fit the process cable package to the <i>clamp holder with plastic clamp</i>. Position of cables and hoses is shown in the figure.</p> <p> CAUTION</p> <p>Do not tighten the brass couplings for water and air with excessive force.</p> <p> CAUTION</p> <p>If the M12 Ethernet connector is not tightened correctly, there is a risk that the connector can loosen and the cable shield gets disconnected, which will require retightening with the correct torque tools.</p> <p>For secure connection, always tighten at the knurled screw with correct torque and by using proper torque tool, e.g. M12 dynamometric screwdriver SW15 (09 99 000 0646 (article number at Harting Technology Group)).</p>	<p>Tightening torque:</p> <ul style="list-style-type: none"> • Brass coupling 1/2": 31 Nm. • Stainless steel coupling 1/2": 49 Nm. • Brass coupling 3/8": 17 Nm. • Mixed metals: Use the lower tightening torque value of the two metals. <p>Always apply Molykote P1900 to stainless steel couplings and apply if needed for couplings of mixed metals or brass.</p> <p>Tightening torque, Ethernet M12: 0.6 Nm.</p> <p>Shown in the figure Location of the cable package on page 109.</p>  <p>xx080000079</p> <p>Positions:</p> <ul style="list-style-type: none"> • A: PROC 1 (blue) • B: PROC 2 (green) • C: PROC 3 (red) • D: PROC 4 (black) • E: Signal cable • F: Weld cable

Continues on next page

2.2.8.2 Fitting the cable package IRBDP SW5 CE (DressPack Basic)

Continued

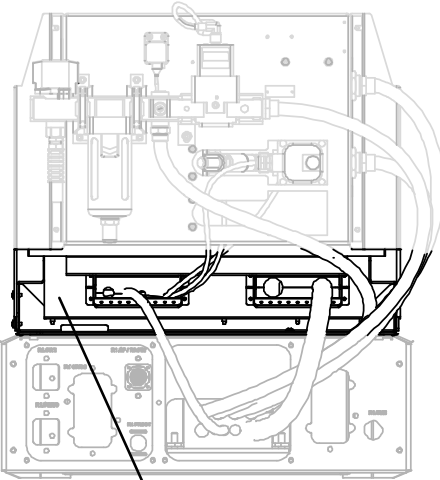
	Action	Note
8	Fit the process cable package to the <i>connection box</i> .	 <p data-bbox="1161 875 1193 909">A</p> <p data-bbox="986 920 1093 936">xx080000082</p> <p data-bbox="986 958 1054 981">Parts:</p> <ul data-bbox="1018 983 1262 1008" style="list-style-type: none"> • A: Connection box

Continues on next page

2 Installation

2.2.8.2 Fitting the cable package IRBDP SW5 CE (DressPack Basic)

Continued

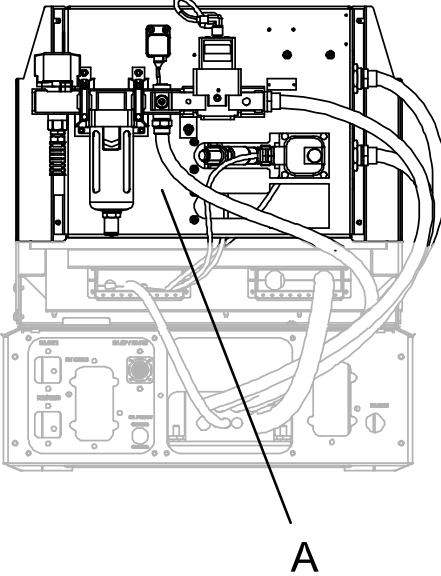
	Action	Note
9	<p>Fit the process cable package to the <i>water and air unit</i>.</p> <p> CAUTION</p> <p>Do not tighten the brass couplings for water and air with excessive force.</p>	<p>Tightening torque:</p> <ul style="list-style-type: none"> • Brass coupling 1/2": 31 Nm. • Stainless steel coupling 1/2": 49 Nm. • Brass coupling 3/8": 17 Nm. • Mixed metals: Use the lower tightening torque value of the two metals. <p>Always apply Molykote P1900 to stainless steel couplings and apply if needed for couplings of mixed metals or brass.</p>  <p>xx0800000083</p> <p>Parts:</p> <ul style="list-style-type: none"> • A: Water and air unit
10	<p>Fit the process cable package to the <i>turn plate</i> with the <i>spiral hose clamp</i>.</p>	<p>Shown in the figure Location of the cable package on page 109.</p>
11	<p>Secure the process cable package to the <i>attachment balancing cylinder</i> with the <i>velcro straps</i>.</p>	<p>Shown in the figure Location of the cable package on page 109.</p>
12	<p>Fit the process cable package to the <i>gripping clamp</i> on the <i>lower arm plate</i>.</p>	<p>Shown in the figure Location of the cable package on page 109.</p>
13	<p>Secure the process cable package with the <i>velcro strap</i> to the <i>lower arm plate</i>.</p>	<p>Shown in the figure Location of the cable package on page 109.</p>
14	<p>Fit the process cable package to the <i>gripping clamp</i> on the <i>adjustable bracket</i>.</p>	<p>Shown in the figure Location of the cable package on page 109.</p>
15	<p>Fit the process cable package in the <i>ball joint housing</i> on the <i>adjustable bracket</i>.</p>	<p>Shown in the figure Location of the cable package on page 109.</p>
16	<p>Fit the process cable package on the <i>ball joint housing</i> on the <i>process cable support axis 6</i>.</p>	<p>Shown in the figure Location of the cable package on page 109.</p>

2.2.9 Installation of IRBDP SW6 UI, IRBDP MH6 UI and IRBDP SW6 LE, LeanID

2.2.9.1 Fitting the attachments of IRBDP SW6 UI and IRBDP MH6 UI, LeanID

Location of the attachments of the cable package

The attachments of the cable package are located as shown in the figures.

The figure shows the attachments of the cable packages IRBDP SW6 UI and IRBDP MH6 UI.

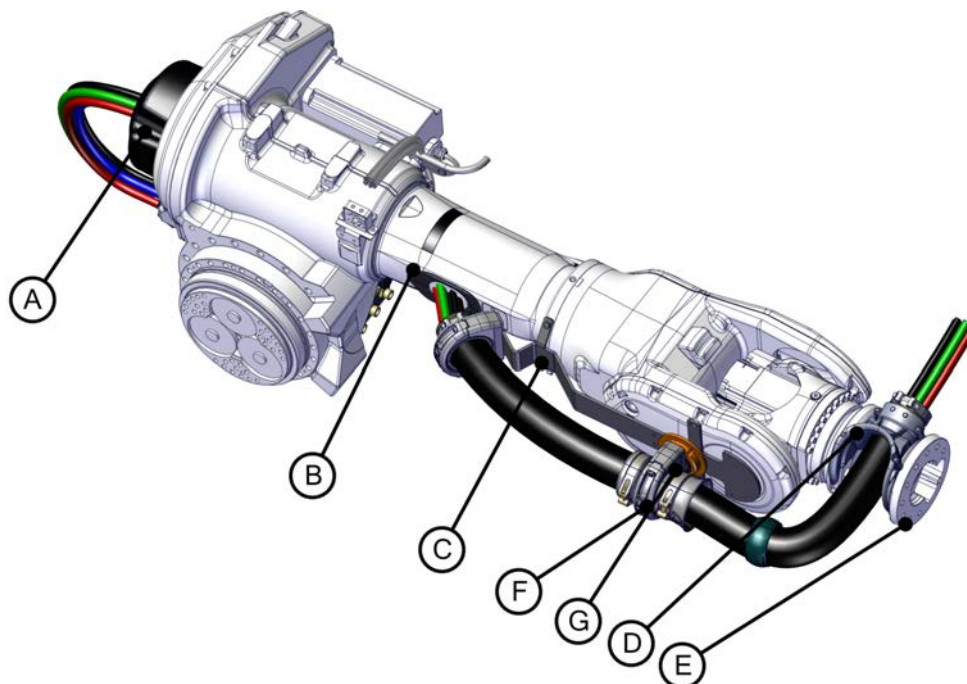

xx150000870

A	Cover
B	Insert (and tube, inside upper arm)
C	Upper arm bracket
D	Axis 6 bracket
E	Process turning disc
F	Ball joint housing
G	Bearing housing

Required parts

Equipment, etc.	Art. no.	Note
Material set cable package IRBDP SW6 UI and IRBDP MH6 UI.		

Continues on next page

2 Installation

2.2.9.1 Fitting the attachments of IRBDP SW6 UI and IRBDP MH6 UI, LeanID

Continued

Required tools and equipment

Equipment, etc.	Article number	Note
Standard toolkit	-	Content is defined in section Standard toolkit on page 357 .

Required consumable

Consumable	Article number	Note
Locking liquid	3HAB7116-1	Loctite 243 For locking attachment screws.

Fitting the cable attachments - IRBDP SW6 UI and IRBDP MH6 UI

Use this procedure to fit the cable attachments of the cable packages IRBDP SW6 UI and IRBDP MH6 UI.

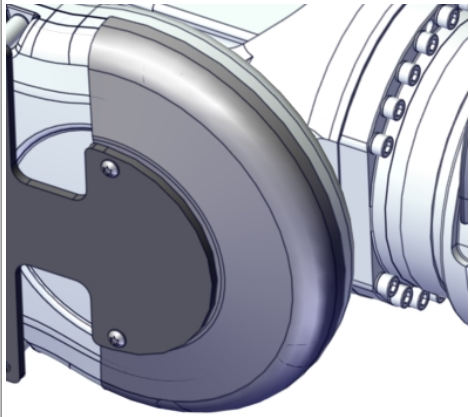
Action	Note
1 Move the robot to a suitable position for fitting the cable attachments on the upper arm.	
2  DANGER Turn off all: <ul style="list-style-type: none">• electric power supply• air pressure supply to the robot, before starting the repair work on the robot.	
3 Fasten the cover on the upper arm bracket.	 <small>xx1500000931</small> Screw M6x10 (2 pcs) and Nut M6

Continues on next page

2.2.9.1 Fitting the attachments of IRBDP SW6 UI and IRBDP MH6 UI, LeanID Continued

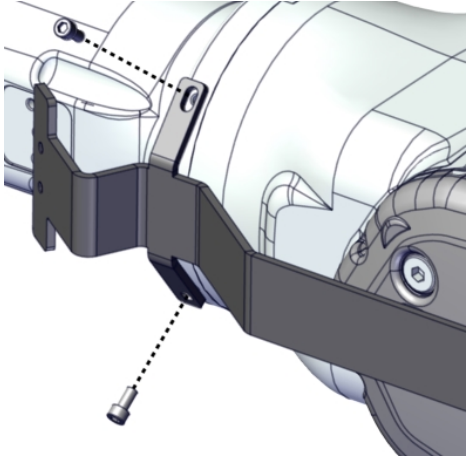
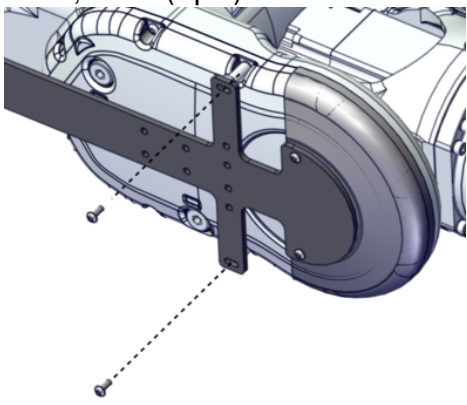
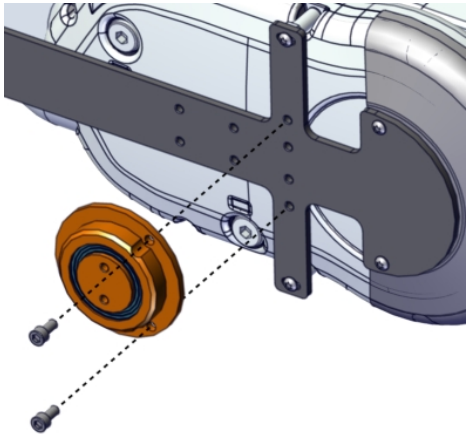
	Action	Note
4	Fasten the upper arm bracket. Lock screws with locking liquid (Loctite 243).	 <p>xx150000929</p> <p>Screw, M8x16 (2 pcs)</p>  <p>xx150000930</p> <p>M6 Distance sleeve Screw, M6x16 (2 pcs)</p>
5	Fasten bearing with housing. Lock screws with locking liquid (Loctite 243).	 <p>xx150000932</p> <p>Screw, M</p>

Continues on next page

2 Installation

2.2.9.1 Fitting the attachments of IRBDP SW6 UI and IRBDP MH6 UI, LeanID

Continued

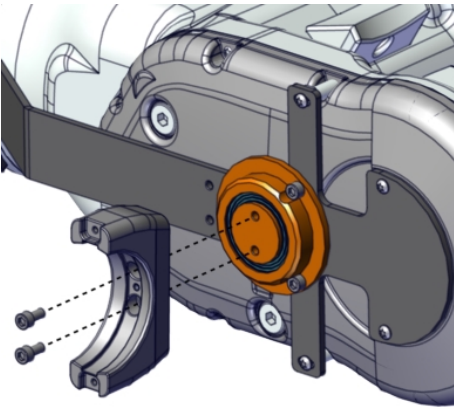
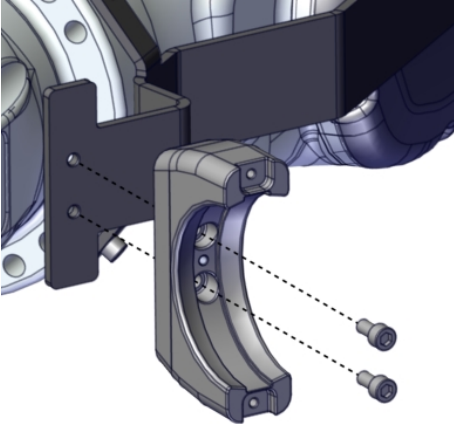
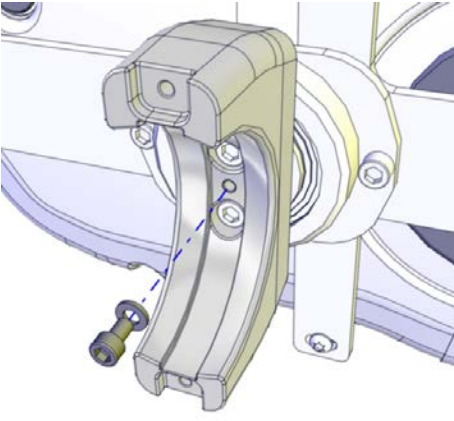
	Action	Note
6	Fasten the the two lower ball joint housing parts. Lock screws with locking liquid (Loctite 243).	 <p data-bbox="943 790 1050 808">xx150000933</p> <p data-bbox="943 826 1353 857">Screw, M8x16 quality 8.8-A2F (2 pcs)</p>  <p data-bbox="943 1339 1050 1357">xx150000934</p> <p data-bbox="943 1375 1353 1406">Screw, M8x16 quality 8.8-A2F (2 pcs)</p>
7	Fit the attachment screw and washer in the middle hole of the housing lower part.	 <p data-bbox="943 1850 1050 1868">xx120000152</p>

Continues on next page

2.2.9.1 Fitting the attachments of IRBDP SW6 UI and IRBDP MH6 UI, LeanID Continued

Fitting insert, tube and cover

Use this procedure to fit the insert, the tube and the cover.

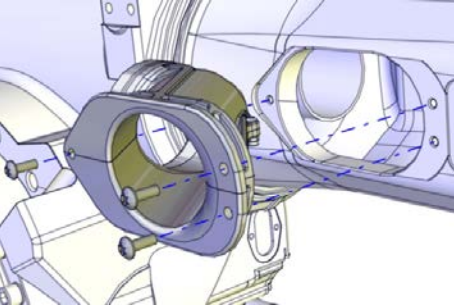
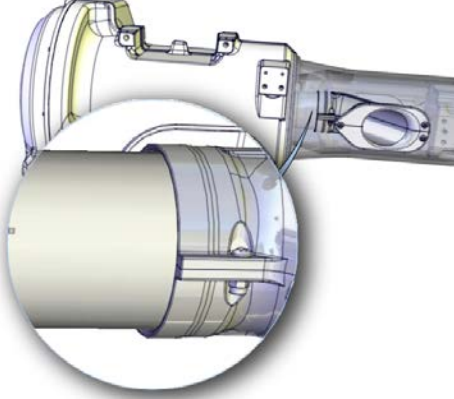
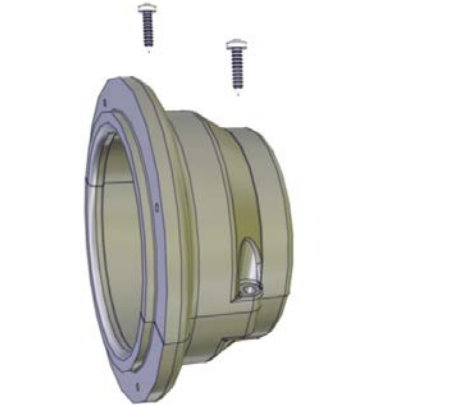

	Action	Note
1	Fit the insert. Lock screws with locking liquid (Loctite 243).	 <p data-bbox="975 712 1082 734">xx120000042</p> <p data-bbox="975 745 1305 779">Screw, M6x16 8.8-A2F (3 pcs)</p>
2	Insert the tube into the arm tube and fit it into the insert.	 <p data-bbox="975 1196 1082 1218">xx120000043</p>
3	Mount the two parts of the tube guiding ring.	 <p data-bbox="975 1688 1082 1711">xx1200000162</p> <p data-bbox="975 1722 1353 1753">Pan head screw ST3.9x16 (2 pcs).</p>

Continues on next page

2 Installation

2.2.9.1 Fitting the attachments of IRBDP SW6 UI and IRBDP MH6 UI, LeanID

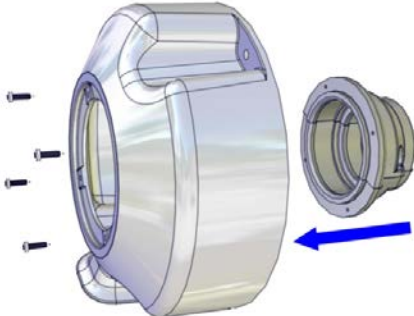
Continued

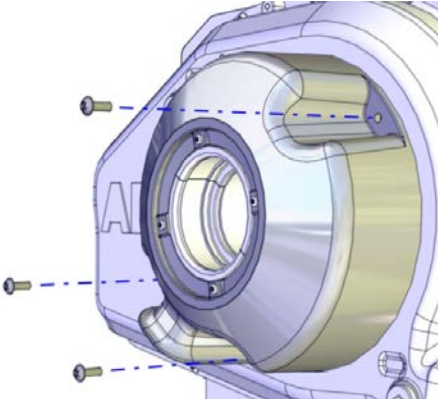
	Action	Note
4	Fit the tube guiding ring in the cover.	 <p data-bbox="943 667 1050 685">xx120000044</p> <p data-bbox="943 703 1401 734">Screw, Pan head screw ST3.9x16 (4 pcs).</p>
5	<p data-bbox="464 752 935 857">Fit the cover, with the tube guiding ring, on the tube and secure it to the armhouse cover. Lock screws with locking liquid (Loctite 243).</p> <p data-bbox="464 875 528 931"> Note</p> <p data-bbox="464 949 903 1003">Check that the tube is fitted correctly in both ends, when fitting the cover.</p>	 <p data-bbox="943 1153 1050 1171">xx120000045</p> <p data-bbox="943 1189 1369 1220">Screws, M6x16 quality 8.8-A2F (3 pcs)</p>

2.2.9.2 Fitting the attachments of IRBDP SW6 LE, LeanID

Location of the attachments

Continues on next page

2 Installation

2.2.9.2 Fitting the attachments of IRBDP SW6 LE, LeanID

Continued

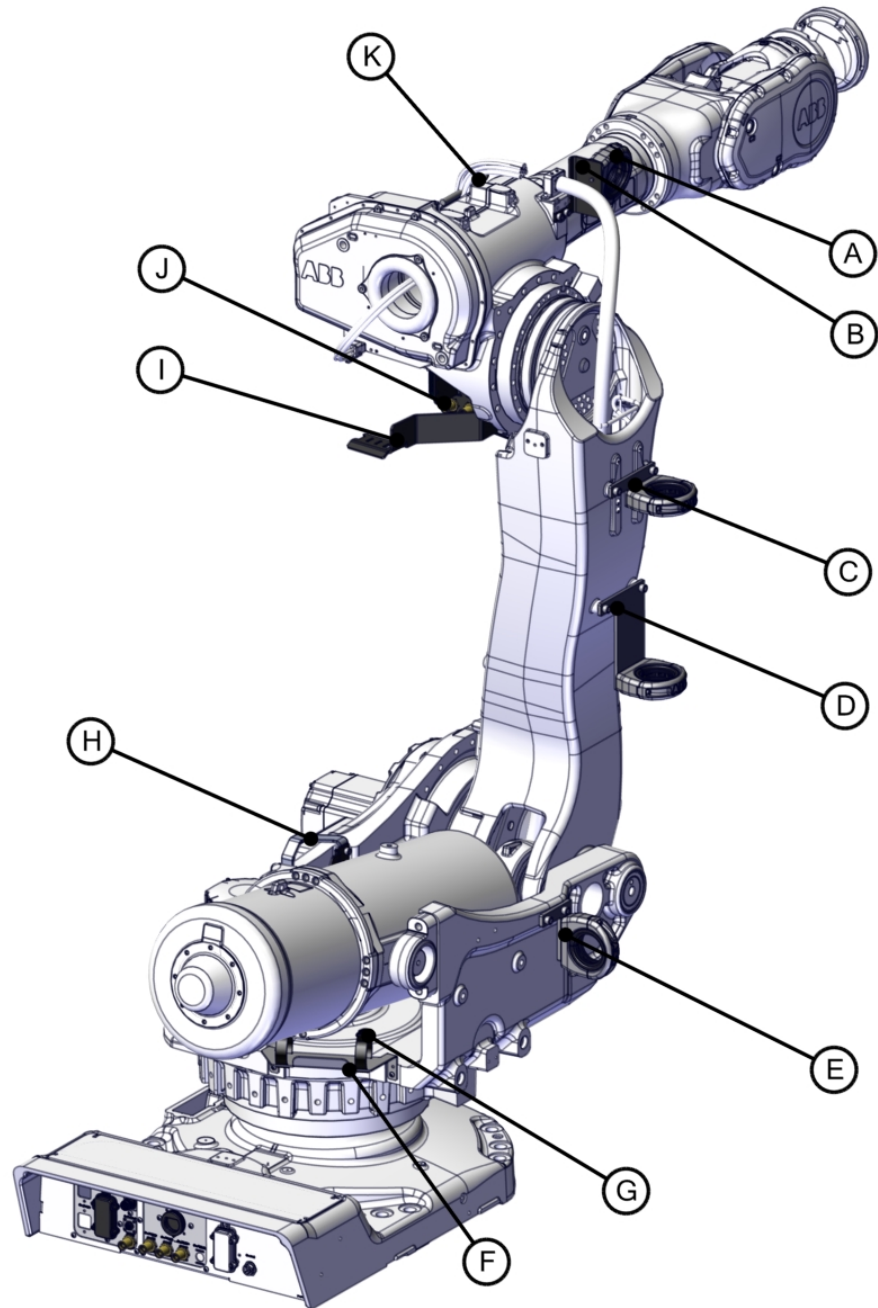

xx150000871

A	Ball joint housing
B	Bracket
C	Bracket for cable clamp
D	Bracket
E	Bracket
F	Cable conduit
G	Strap
H	Frame adapter plate

Continues on next page

I	Bracket
J	Connection plate
K	Cable guide

Required parts

Spare part	Article number	Note
Material set IRBDP SW6 LE	3HAC054823-001	

Required tools and equipment

Equipment	Article number	Note
Standard toolkit		Content is defined in section Standard toolkit on page 357 .

Required consumable

Consumable	Article number	Note
Locking liquid	3HAB7116-1	Loctite 243 For locking attachment screws.

Fitting the cable attachments - IRBDP SW6 LE, Lean ID

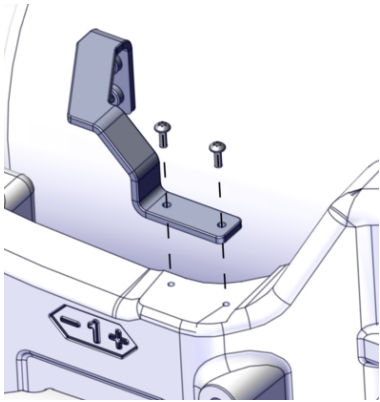
	Action	Note
1	Move the robot to a suitable position for fitting the cable attachments on the lower arm.	
2	 DANGER Turn off all: <ul style="list-style-type: none"> • electric power supply • air pressure supply to the robot, before starting the repair work on the robot.	
3	Fit the frame adapter plate with its attachment screws. Lock screws with locking liquid (Loctite 243).	 xx1500000872 Screw M6x16 (2 pcs)

Continues on next page

2 Installation

2.2.9.2 Fitting the attachments of IRBDP SW6 LE, LeanID

Continued

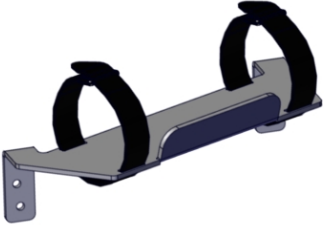
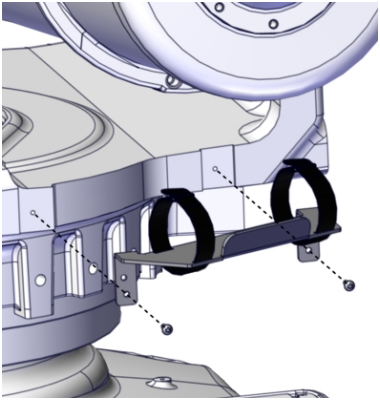
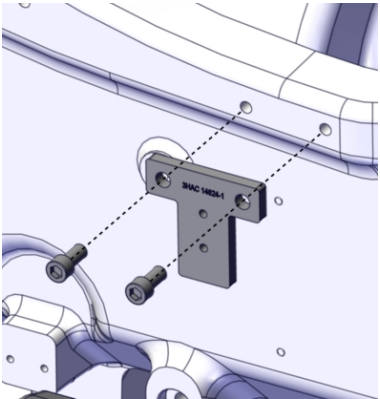
	Action	Note
4	Fit the straps on the cable conduit.	 xx1500000875
5	Fasten the cable conduit. Lock screws with locking liquid (Loctite 243).	 xx1500000876 Screw M6x16 (2 pcs)
6	Fasten the bracket. Lock screws with locking liquid (Loctite 243).	 xx1500000879 Screw M12x25 (2 pcs)

Continues on next page

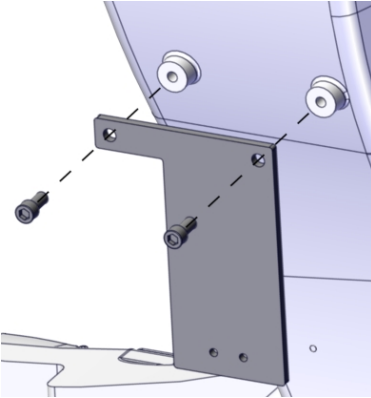
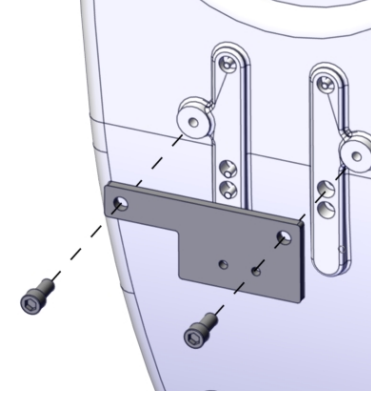
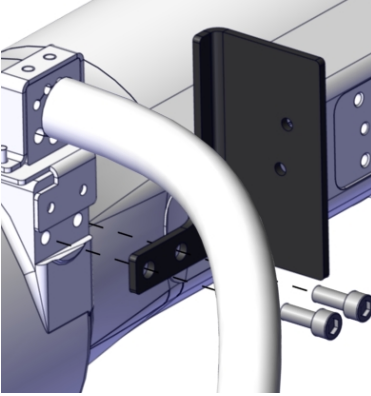
	Action	Note
7	Fasten the bracket. Lock screws with locking liquid (Loctite 243).	 <p data-bbox="1061 712 1165 728">xx1500000880</p> <p data-bbox="1061 750 1300 772">Screw M12x25 (2 pcs)</p>
8	Fasten the bracket for cable clamp. Lock screws with locking liquid (Loctite 243).	 <p data-bbox="1061 1193 1165 1209">xx1500000881</p> <p data-bbox="1061 1232 1300 1254">Screw M12x25 (2 pcs)</p>
9	Fasten the bracket. Lock screws with locking liquid (Loctite 243).	 <p data-bbox="1061 1675 1165 1691">xx1500000882</p> <p data-bbox="1061 1713 1300 1736">Screw M10x16 (2 pcs)</p>

Continues on next page

2 Installation

2.2.9.2 Fitting the attachments of IRBDP SW6 LE, LeanID

Continued

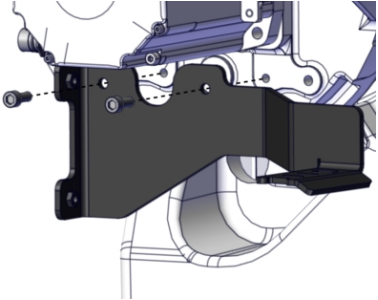
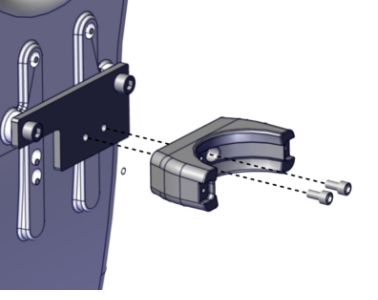
	Action	Note
10	Fasten the bracket. Lock screws with locking liquid (Loctite 243).	 <p data-bbox="1031 618 1134 633">xx150000883</p> <p data-bbox="1031 651 1273 680">Screw M10x16 (2 pcs)</p>
11	Fasten all four ball joint housing lower part. Lock screws with locking liquid (Loctite 243).	 <p data-bbox="1031 994 1134 1010">xx150000885</p> <p data-bbox="1031 1028 1390 1086">Screw, M8x16 quality 8.8-A2F (2 pcs)</p>

2.2.9.3 Fitting the cable package IRBDP SW6 LE and IRBDP MH6 UI and SW6 UI, LeanID

Location of the cable package IRBDP SW6 LE, IRBDP MH6 and SW6 UI

The cable package is located as shown in the figure. The figure shows the cable package IRBDP SW6 LE and IRBDP SW6 UI. The principle of IRBDP MH6 UI is the same as IRBDP SW6 UI.

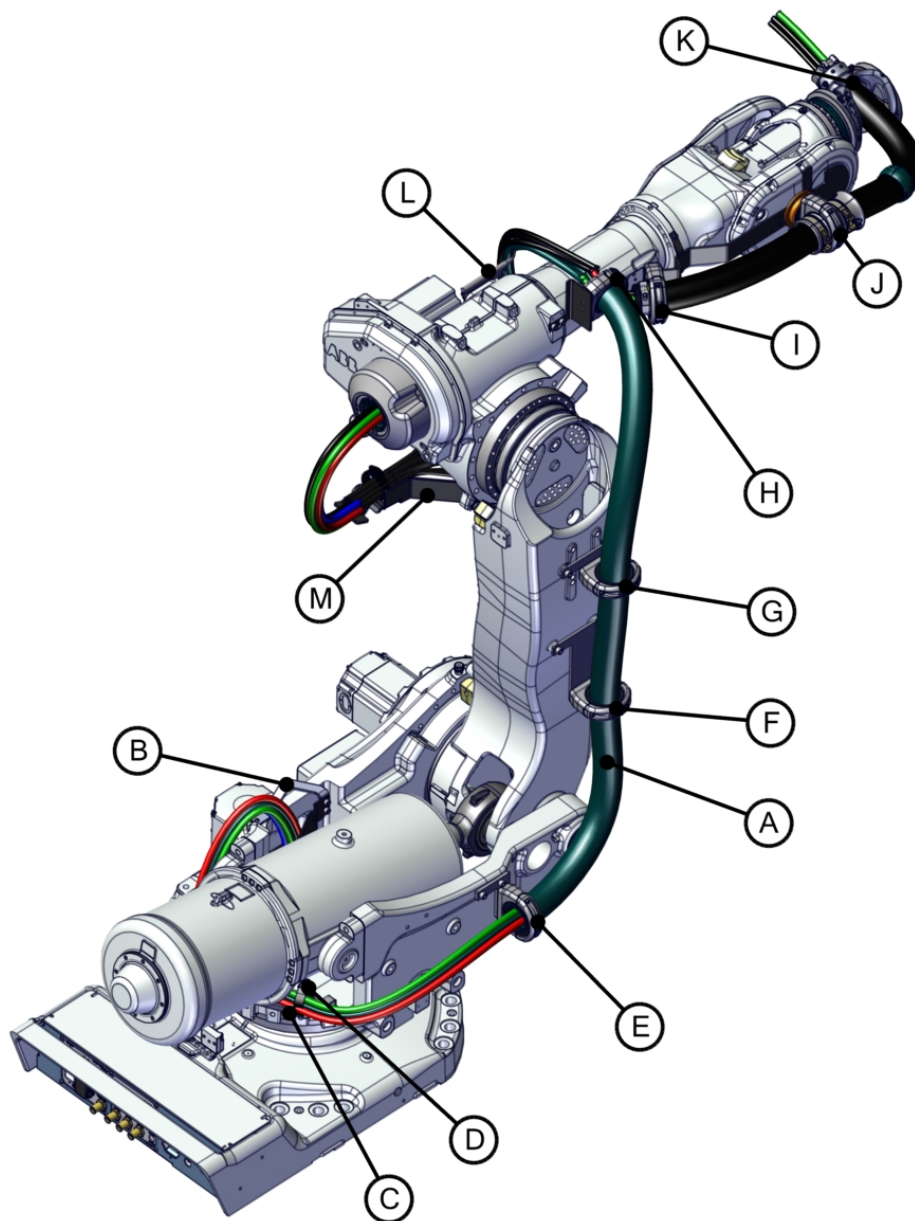

xx150000892

A	Cable package
B	Frame adapter plate
C	Cable conduit

Continues on next page

2 Installation

2.2.9.3 Fitting the cable package IRBDP SW6 LE and IRBDP MH6 UI and SW6 UI, LeanID

Continued

D	Strap
E	Ball joint housing
F	Ball joint housing
G	Ball joint housing
H	Ball joint housing
I	Ball joint housing
J	Ball joint housing
K	Axis 6 bracket
L	Velcro straps
M	Connection plate with bracket

Required parts

Spare part	Article number	Note
Cable package IRBDP SW6 LE	See DressPack cable package IRBDP SW6 LE LeanID on page 375	
Cable package IRBDP SW6 UI	See DressPack cable package IRBDP SW6 UI LeanID on page 377	
or Cable package IRBDP MH6 UI	See DressPack cable package IRBDP MH6 UI LeanID on page 378	

Required tools and equipment

Equipment, etc.	Article number	Note
Standard toolkit	-	Content is defined in section Standard toolkit on page 357 .



Required consumable

Consumable	Article number	Note
Locking liquid	3HAB7116-1	Loctite 243, for locking screws.
Cable grease		

Continues on next page

Fitting the cable package

Connect the lower cable package at the base

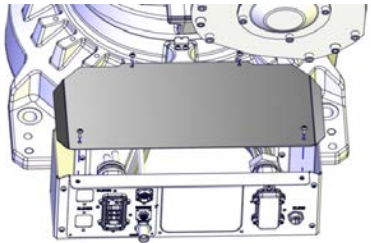
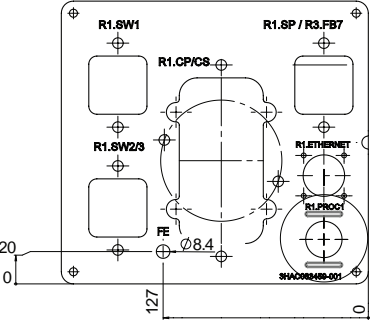
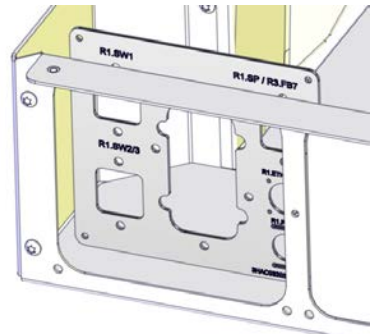
	Action	Note
1	 DANGER Turn off all: <ul style="list-style-type: none"> • electric power supply • air pressure supply to the robot, before starting the repair work on the robot.	
2	 CAUTION The cable package is sensitive to mechanical damage. Handle it with care in order to avoid damaging the cabling or the connectors.	
3	Remove the rear cover plate.	 xx1400000080
4	Only for Paramulti DressPack and for spare part replacement. The Paramulti DressPack spare part includes functional ground. If the installed DressPack has not included functional ground previously, following action needs to be done: Drill an 8.4 mm mm hole in the customer plate according to the figure.	 xx1900001268
5	Fit the customer plate.	 xx1400001146 Screw, M6x16 8.8-A2F (4 pcs)

Continues on next page

2 Installation

2.2.9.3 Fitting the cable package IRBDP SW6 LE and IRBDP MH6 UI and SW6 UI, LeanID

Continued

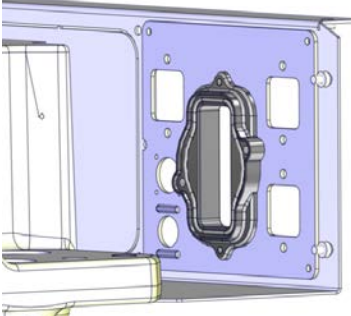
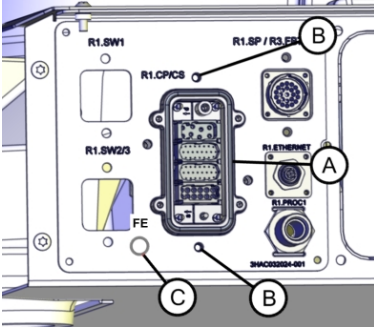
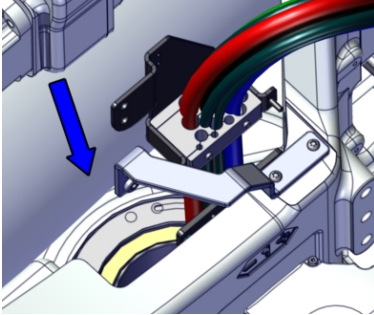
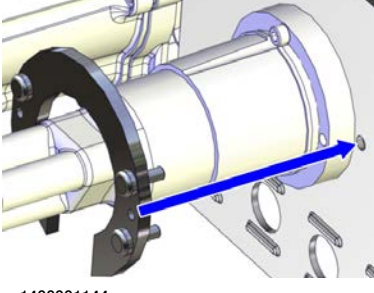
	Action	Note
6	Fit the adapter complete to the customer plate.	 <p>xx1400001140</p>
7	Fasten the adapter complete to the customer plate.	 <p>xx1400001141</p> <p>Parts:</p> <ul style="list-style-type: none"> • A: Adapter complete • B: Attachment screws M6x16 8.8-A2F (2 pcs) • C: Functional ground
8	<p>Run the cables down through the center hole of axis 1, in the following order:</p> <ul style="list-style-type: none"> • Signal cables (Spot welding) • Hoses • Check that the signal cables and hoses do not end up between the motor cables. • Check that cables and hoses do not cross each other or get twisted. 	 <p>xx1500000895</p>
9	Fit the weld connector bracket.	 <p>xx1400001144</p>

Continues on next page

2.2.9.3 Fitting the cable package IRBDP SW6 LE and IRBDP MH6 UI and SW6 UI, LeanID Continued

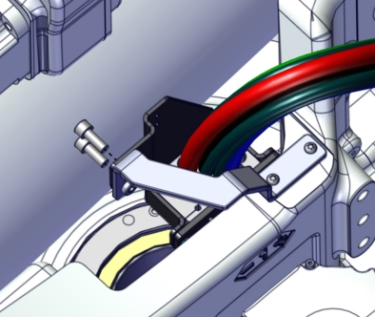
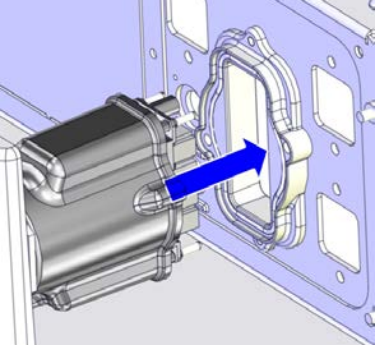
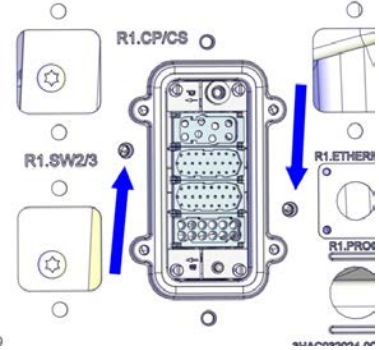



	Action	Note
10	Fasten the cable package bracket to the frame adapter plate. Lock screws with locking liquid, Loctite 243.	 <p data-bbox="1062 636 1166 656">xx150000896</p> <p data-bbox="1062 674 1442 730">Spot welding: Screw, M10x25 8.8-A3-F (2 pcs)</p> <p data-bbox="1062 734 1442 790">Material handling: Screw, M6x16 8.8-A2F (2 pcs)</p>
11	Fit the R1.CP/CS cable to the customer plate.	 <p data-bbox="1062 1158 1166 1178">xx1400001142</p>
12	Secure the R1.CP/CS connector.	 <p data-bbox="1062 1565 1166 1585">xx1400001143</p> <p data-bbox="1062 1603 1442 1637">Screw, M6x20 8.8-A2F (2 pcs)</p>

Continues on next page

2 Installation

2.2.9.3 Fitting the cable package IRBDP SW6 LE and IRBDP MH6 UI and SW6 UI, LeanID

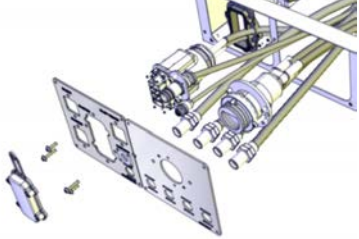
Continued

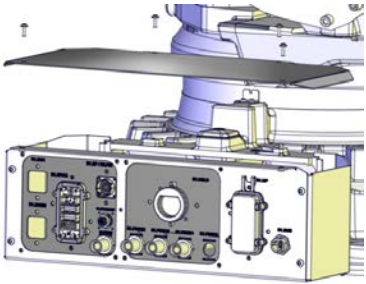
	Action	Note
13	<p>Connect the hose connectors to the customer plate.</p> <p> CAUTION</p> <p>Do not tighten the brass couplings for water and air with excessive force.</p> <p> CAUTION</p> <p>Make sure that no cables or hoses are twisted or strained. Reroute if necessary.</p>	<p>Tightening torque:</p> <ul style="list-style-type: none"> • Brass coupling 1/2": 31 Nm. • Stainless steel coupling 1/2": 49 Nm. • Brass coupling 3/8": 17 Nm. • Mixed metals: Use the lower tightening torque value of the two metals. <p>Always apply Molykote P1900 to stainless steel couplings and apply if needed for couplings of mixed metals or brass.</p>  <p>xx1200000088</p>
14	<p>Connect the rest of the cable connectors to the customer plate.</p> <p>Only for Paramulti DressPack: Also connect functional ground.</p> <p> CAUTION</p> <p>Make sure that no cables or hoses are twisted or strained. Reroute if necessary.</p>	
15	<p>Refit the rear cover.</p>	 <p>xx1400000197</p> <p>Screw M6x16 8.8-A2F (4 pcs)</p>

Fasten the cable package - Lower arm

	Action	Note
1	<p> DANGER</p> <p>Turn off all:</p> <ul style="list-style-type: none"> • electric power supply • air pressure supply <p>to the robot, before starting the repair work on the robot.</p>	

Continues on next page

2.2.9.3 Fitting the cable package IRBDP SW6 LE and IRBDP MH6 UI and SW6 UI, LeanID

Continued

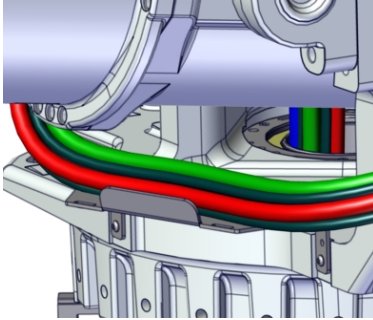
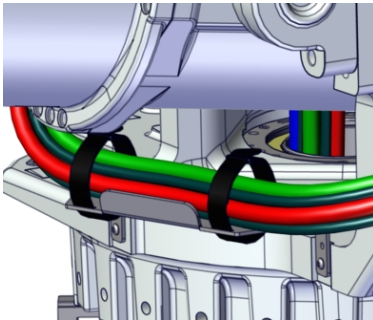
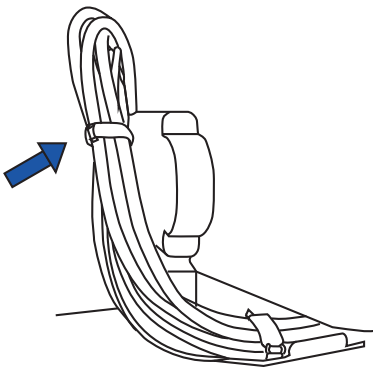

	Action	Note
2	<p> CAUTION</p> <p>The cable package is sensitive to mechanical damage. Handle it with care in order to avoid damaging the cabling or the connectors.</p>	
3	<p>Place the cable package through the cable conduit below the balancing cylinder.</p>	 <p>xx150000899</p>
4	<p>Fasten the cable package with the two straps.</p>	 <p>xx150000898</p>
5	<p>Fasten a velcro strap around the cable package between axis-1 bracket and the cable conduit.</p>	 <p>xx150000897</p>

Continues on next page

2 Installation

2.2.9.3 Fitting the cable package IRBDP SW6 LE and IRBDP MH6 UI and SW6 UI, LeanID

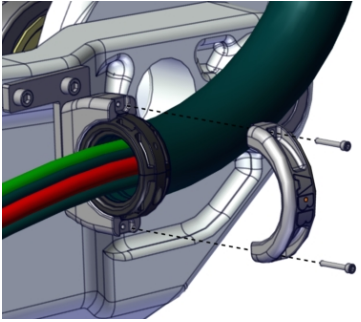
Continued

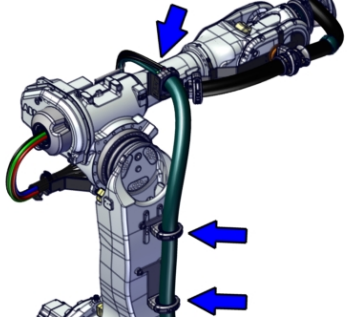
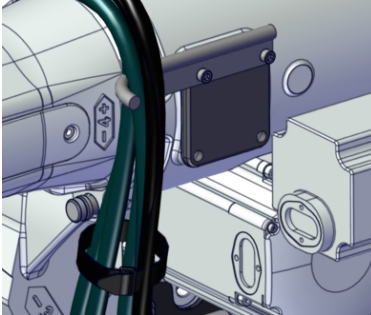

	Action	Note
6	<p>Fasten the cable package in the axis-2 ball joint housing.</p> <p> Note</p> <p>Be careful not to loose the small o-ring! The purpose of the o-ring is to keep the screws in place in the housing, upper part.</p>	 <p>xx1500000900</p> <p>Screw, M6x40 8.8-A2F (2 pcs)</p>
7	<p> CAUTION</p> <p>Do not change the position of the clamp inserts on the protection hose, being fitted in the ball joint housings. If the position is changed it will alter the bending movement of the protection hose, when the arms are moved.</p> <p>A change of position of the clamp inserts may result in serious damage to the cable package.</p>	
8	<p>Fasten the cable package in the ball joint housings on the lower arm and on the tubular shaft.</p>	 <p>xx1500000901</p> <p>Screw, M6x40 8.8-A2F (6 pcs)</p>
9	<p>Put the cable package over the cable guide and fasten it with a velcro strap. Fit another velcro strap around the cable harness.</p>	 <p>xx1500000902</p>

Continues on next page

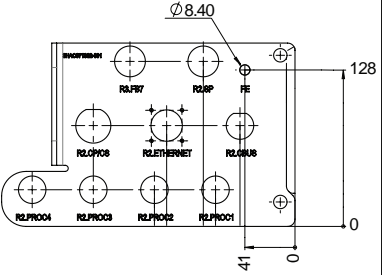
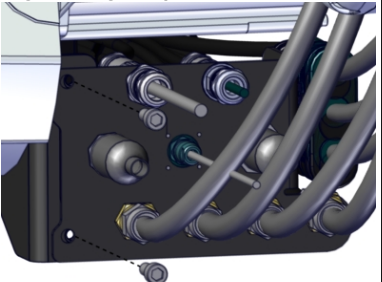
2.2.9.3 Fitting the cable package IRBDP SW6 LE and IRBDP MH6 UI and SW6 UI, LeanID Continued

	Action	Note
10	<p>Only for Paramulti DressPack and for spare part replacement.</p> <p>The Paramulti DressPack spare part includes functional ground. If the installed DressPack has not included functional ground previously, following action needs to be done:</p> <p>Drill an 8.4 mm hole in the customer plate according to the figure.</p>	 <p>xx1900001269</p>
11	<p>Fasten the connection plate. Lock screws with locking liquid (Loctite 243).</p>	<p>Tightening torque: 47 Nm</p>  <p>xx1500000903</p> <p>Screw M10x25 8.8-A3F (2 pcs)</p>
12	<p>Fit a velcro strap around the cable harness.</p>	

Route the cable package - Upper arm

	Action	Note
1	<p>Move the robot to a comfortable working position.</p>	
2	 <p>DANGER</p> <p>Turn off all:</p> <ul style="list-style-type: none"> • electric power supply • air pressure supply <p>to the robot, before starting the repair work on the robot.</p>	
3	 <p>CAUTION</p> <p>The cable package is sensitive to mechanical damage. Handle it with care in order to avoid damaging the cabling or the connectors.</p>	
4	 <p>Tip</p> <p>This procedure is best done by two persons working together - one pushing cabling and hoses into the tube and the other pulling them out at the wrist.</p>	

Continues on next page

2 Installation

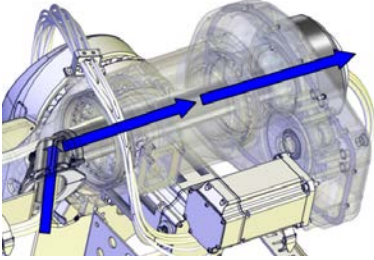

2.2.9.3 Fitting the cable package IRBDP SW6 LE and IRBDP MH6 UI and SW6 UI, LeanID

Continued

	Action	Note
5	<p>Carefully push the cable package into the insert, through the tube and out in the back of the arm housing.</p> <p> Tip</p> <p>The following order is preferable:</p> <ol style="list-style-type: none"> 1 Cables 2 Hoses 3 Weld cables (where applicable) 	 <p>xx140000095</p>

Apply cable grease

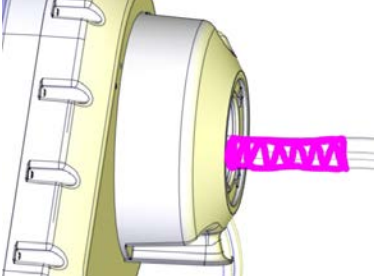
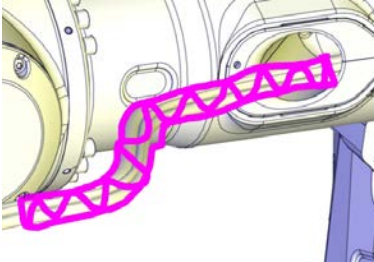

It is necessary to apply cable grease on the cable package inside the tube.

	Action	Note
1	Carefully pull the cable package out 10 to 15 centimeters longer than the final assembly position.	
2	Apply grease on the highlighted area.	 <p>xx1400001389</p>
3	Carefully push the cable package back into the tube and out through the insert until the area where grease was applied, is visible and able to reach.	
4	Apply grease on the highlighted area, so that the cable package inside the tube is covered with cable grease all the way through.	 <p>xx1400001390</p>
5	Carefully push the cable package back in through the insert and into its mounting position in the tube.	
6	<p> Note</p> <p>Make sure the cables and hoses are not twisted through the upper arm.</p>	

Continues on next page

2.2.9.3 Fitting the cable package IRBDP SW6 LE and IRBDP MH6 UI and SW6 UI, LeanID Continued

Connect the cable package

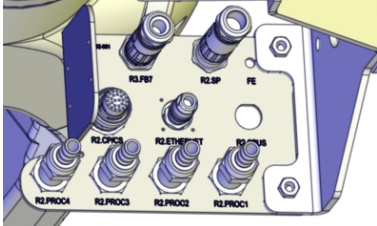
	Action	Note
1	<p>Connect the hose and cable connectors on the connection plate.</p> <p>Only for Paramulti DressPack: Also connect functional ground.</p> <p> CAUTION</p> <p>Do not tighten the brass couplings for water and air with excessive force.</p> <p> Tip</p> <p>Start connecting top connectors, and continue downwards, ending with Proc 4.</p> <p> CAUTION</p> <p>If the M12 Ethernet connector is not tightened correctly, there is a risk that the connector can loosen and the cable shield gets disconnected, which will require retightening with the correct torque tools.</p> <p>For secure connection, always tighten at the knurled screw with correct torque and by using proper torque tool, e.g. M12 dynamometric screwdriver SW15 (09 99 000 0646 (article number at Harting Technology Group)).</p>	<p>Tightening torque:</p> <ul style="list-style-type: none"> • Brass coupling 1/2": 31 Nm. • Stainless steel coupling 1/2": 49 Nm. • Brass coupling 3/8": 17 Nm. • Mixed metals: Use the lower tightening torque value of the two metals. <p>Always apply Molykote P1900 to stainless steel couplings and apply if needed for couplings of mixed metals or brass.</p> <p>Tightening torque, Ethernet M12: 0.6 Nm.</p>  <p>xx1900001267</p>

Weld connector

Only valid for IRBDP SW6 UI.

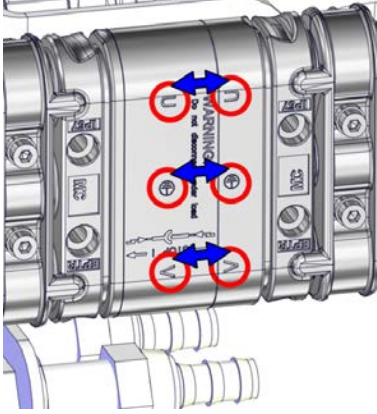
	Action	Note
1	<p>Press (manually) the cables with the crimped-on contact part into the insulation from the back until it perceptibly engages into place to the detent.</p> <p> Note</p> <p>Make sure the pins are pushed all the way into the connector.</p>	 <p>xx1400000216</p>

Continues on next page

2 Installation

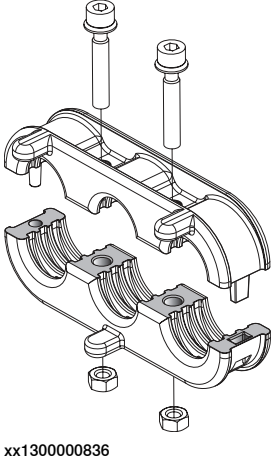
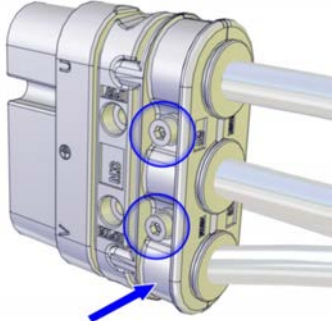
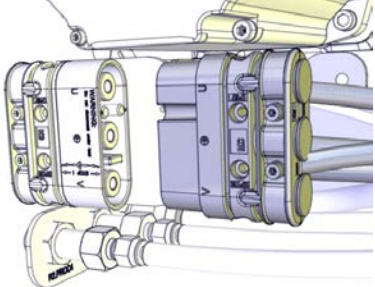
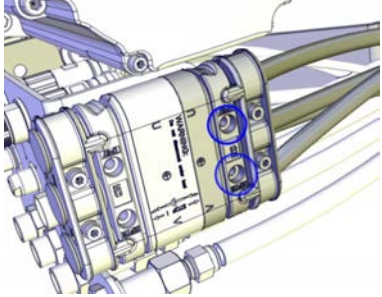

2.2.9.3 Fitting the cable package IRBDP SW6 LE and IRBDP MH6 UI and SW6 UI, LeanID

Continued

	Action	Note
2	<p>Fit the cable strain relief.</p>  <p>xx1300000836</p>	 <p>xx1200000058</p> <p>Screw, M5x25 8.8-A2F (2 pcs)</p>
3	<p>Connect the weld cable.</p>	 <p>xx1200000075</p>
4	<p>Fasten the weld connector to the connection plate.</p>	 <p>xx1200000089</p> <p>Screw, M5x40 8.8-A2F (2 pcs)</p>

Continues on next page

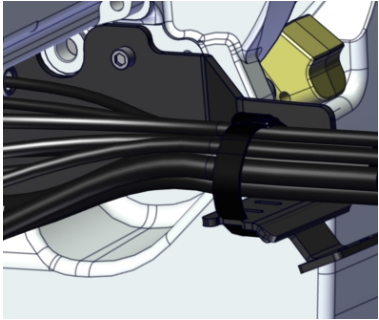
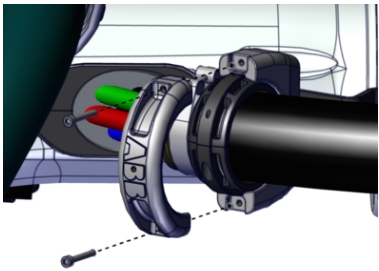
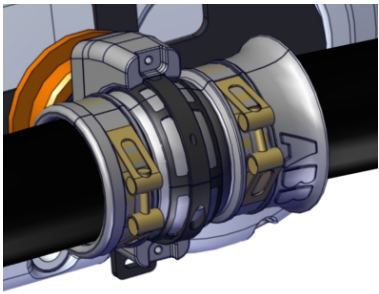
Fasten the cable package

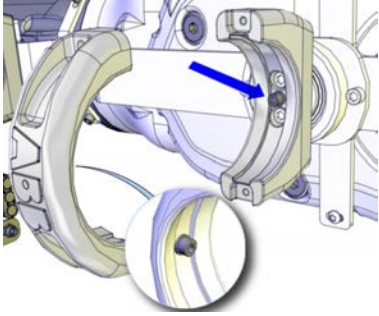

	Action	Note
1	Fasten the cable package to the bracket with a strap.	 <p>xx150000904</p>
2	Fasten the cable package in the ball joint housing.	 <p>xx150000905</p> <p>Screw, M6x40 8.8-A2F (2 pcs)</p>
3	Make sure that the hose reinforcement funnel is fitted correctly, in the direction shown in the figure.	 <p>xx150000906</p>
4	<p>Make sure that the screws (M6x12) fits into the guiding holes of the hose reinforcement funnel when it is fitted in the ball joint housing.</p> <p> CAUTION</p> <p>The hose reinforcement funnel must not be able to rotate inside the ball joint housing when fitted.</p>	 <p>xx120000153</p> <p>Screw, M6x12 8.8-A2F (1+1 pcs)</p>

Continues on next page

2 Installation

2.2.9.3 Fitting the cable package IRBDP SW6 LE and IRBDP MH6 UI and SW6 UI, LeanID

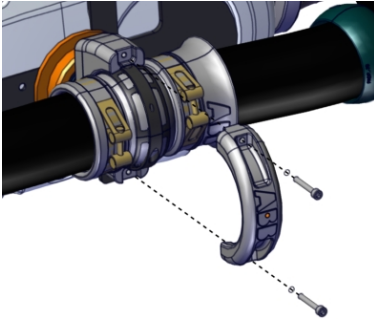
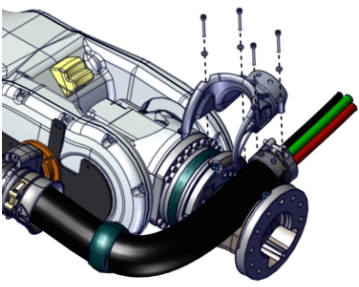
Continued

	Action	Note
5	Fasten the cable package in the ball joint housing.	 <p>xx1500000907</p> <p>Screw, M6x40 8.8-A2F (2 pcs)</p>
6	<p>Only valid for IRBDP SW6 UI:</p> <p>Fasten the cable package with the process turning disc bracket.</p>	 <p>xx1500000908</p> <p>Screw, (9ADA183-31) (4 pcs) and washers (4 pcs)</p>
7	<p> CAUTION</p> <p>Check potential collision risks between the cable package and the wrist, as well as between the cable package and any equipment fitted on the wrist, before restarting the normal production.</p>	
8	Turn on the power and run the present programming at a very slow speed, while checking all movements for collision risk between cable package and wrist.	
9	<p>Only valid for Paramulti:</p> <p>Connect the functional ground to the customer tool Profinet I/O and or tool changer to increase equipotential bonding.</p>	
10	<p> DANGER</p> <p>Make sure all safety requirements are met when performing the first test run. See Test run after installation, maintenance, or repair on page 206.</p>	

Continues on next page

2.2.9.3 Fitting the cable package IRBDP SW6 LE and IRBDP MH6 UI and SW6 UI, LeanID Continued

Check of protective sleeve

The protective hose is protected against wear in exposed areas with a protective sleeve.

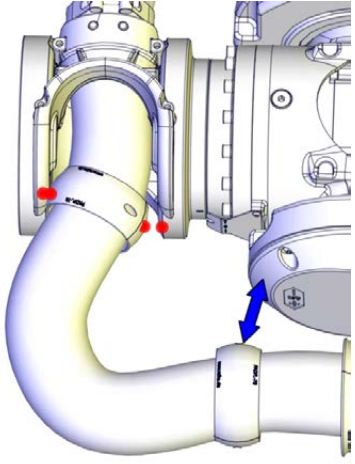
	Action	Note
1	In order to be sure that the protective sleeve is in the correct position, check the position after some hours running.	 <p>xx1400000224</p>
2	If the protective hose is worn somewhere, adjust the position of the protective sleeve.	

2 Installation

2.2.10.1 Fitting the attachments of IRBDP MH LI

2.2.10 Installation of IRBDP MH LI

2.2.10.1 Fitting the attachments of IRBDP MH LI

Location of the cable package attachments

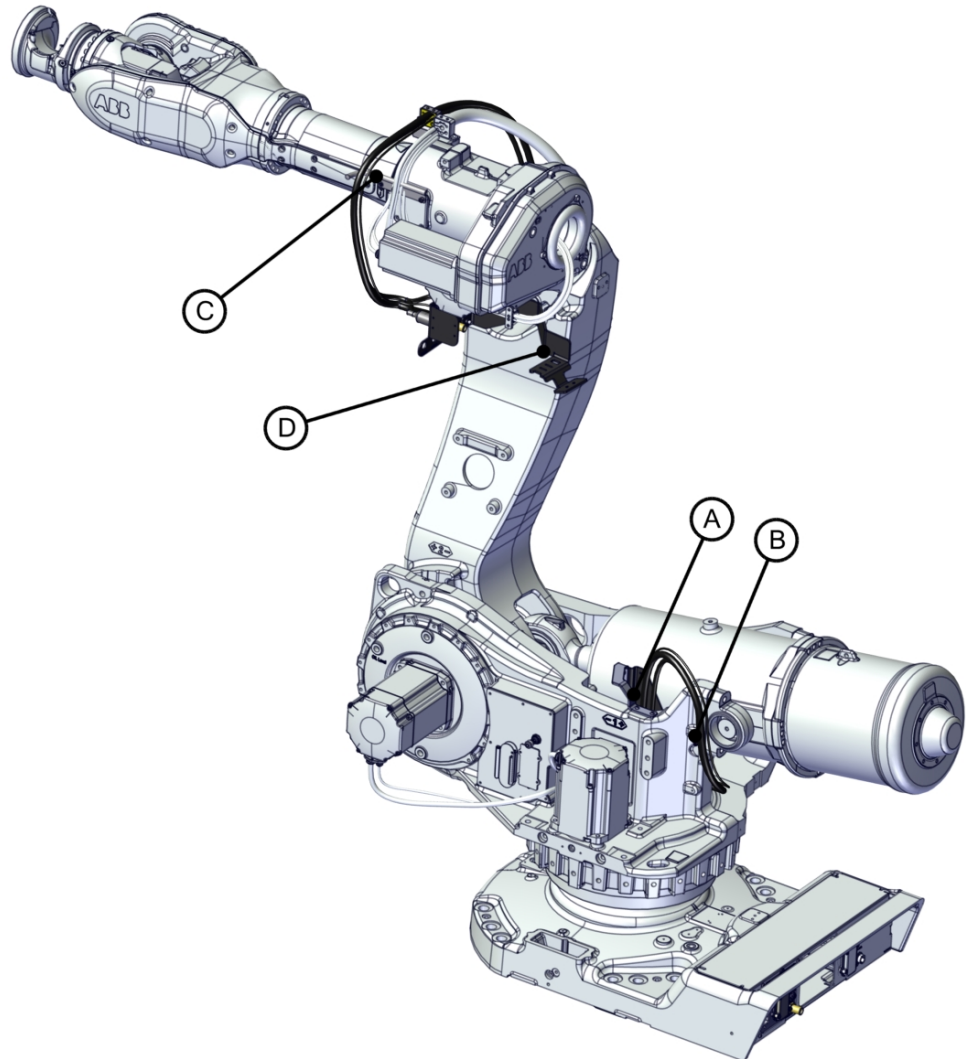

xx1500001588

A	Frame adapter plate
B	Cable fixing bracket
C	Cable guide
D	Mounting plate axis 3
	Velcro straps (6 pcs) (used in description Fitting cable package IRBDP MH LI)

Required parts

Spare part	Article number	Note
Material set IRBDP MH LI	3HAC054825-001	

Continues on next page

Required tools and equipment

Equipment	Article number	Note
Standard toolkit		Content is defined in section Standard toolkit on page 357 .

Required consumable

Consumable	Article number	Note
Locking liquid	3HAB7116-1	Loctite 243 For locking attachment screws.

Fitting the cable package attachments

Use this procedure to fit the cable attachments of the cable package IRBDP MH LI.

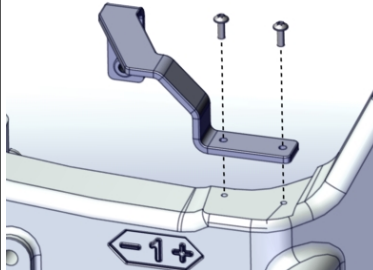
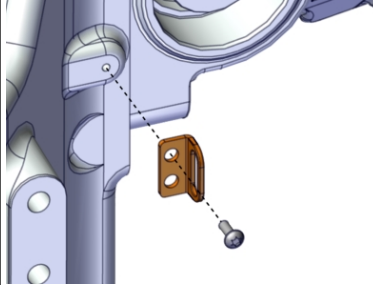
	Action	Note
1	Move the robot to a suitable position for fitting the cable attachments on the lower arm.	
2	 DANGER Turn off all: <ul style="list-style-type: none"> • electric power supply • air pressure supply to the robot, before starting the repair work on the robot.	
3	Fasten the frame adapter plate. Lock screws with locking liquid (Loctite 243).	 xx1500001589 Screw torx, M6x16 8.8-A2F (2 pcs)
4	Fasten the cable fixing bracket. Lock screw with locking liquid (Loctite 243).	 xx1500001590 Screw torx, M6x16 8.8-A2F (1 pcs)

Continues on next page

2 Installation

2.2.10.1 Fitting the attachments of IRBDP MH LI

Continued

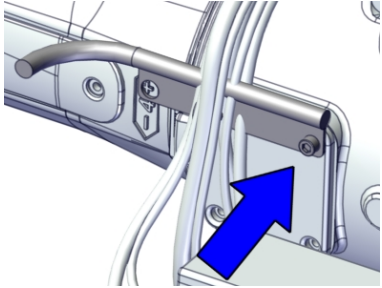
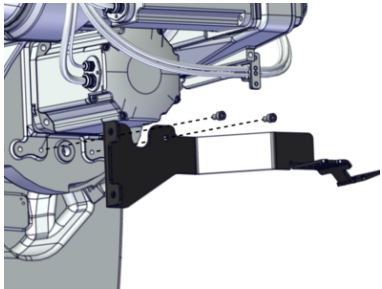
	Action	Note
5	Remove the two top screws on the cover and fasten the cable guide on the cover. Lock screw with locking liquid (Loctite 243).	 xx1500001591
6	Fasten the mounting plate axis 3. Lock screws with locking liquid (Loctite 243).	 xx1500001592 Screw, M10x16 8.8-A2F (2 pcs)

2.2.10.2 Fitting the cable package IRBDP MH LI

Location of the cable package



xx1500001584

Required parts

Spare part	Article number	Note
Cable package IRBDP MH LI	See DressPack cable package IRBDP MH3 LI on page 376	
Material set IRBDP MH LI	3HAC054825-001	only the Velcro straps

Continues on next page

2 Installation

2.2.10.2 Fitting the cable package IRBDP MH LI

Continued

Required tools and equipment





Equipment	Article number	Note
Standard toolkit		Content is defined in section Standard toolkit on page 357 .

Required consumable

Consumable	Article number	Note
Locking liquid	3HAB7116-1	Loctite 243, for locking screws.
Cable grease		

Fitting the cable package IRBDP MH LI

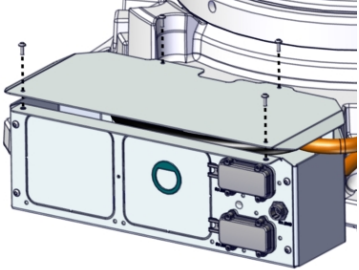
Connect the cable package at the base

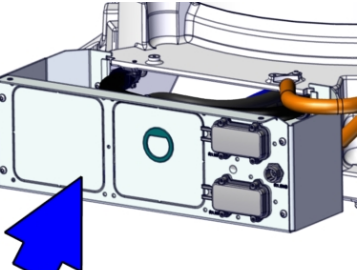
	Action	Note
1	 DANGER Turn off all: <ul style="list-style-type: none"> • electric power supply • hydraulic pressure supply • air pressure supply to the robot, before entering the safeguarded space.	
2	 CAUTION The cable package is sensitive to mechanical damage. Handle it with care in order to avoid damaging the cabling or the connectors.	
3	Remove the rear cover plate.	 xx1500002963
4	Remove the part of the backplate where the customer plate is to be fitted. Hit the removable part carefully with a plastic mallet.  Note Only needed when the DressPack cable package is fitted for the first time.	 xx1500002964



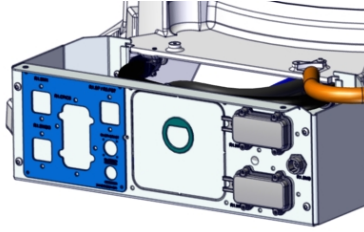
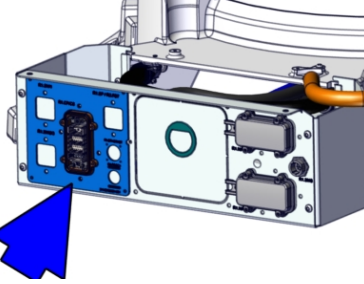
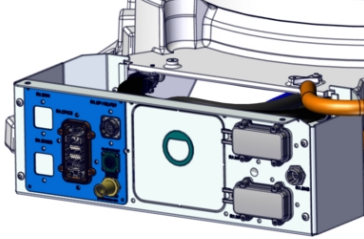
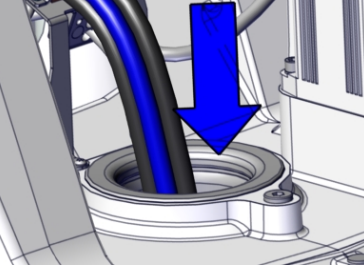

Continues on next page

	Action	Note
5	Fit the customer plate.	 <p data-bbox="1066 595 1166 613">xx1500002965</p> <p data-bbox="1066 633 1286 663">M6x25 A2-70 (4 pcs)</p>
6	Fit the adapter complete.	 <p data-bbox="1066 965 1166 983">xx1500002966</p> <p data-bbox="1066 1003 1406 1055">M6x16 Stainless steel A2-70 (2 pcs)</p>
7	Fit the Profinet bracket.	 <p data-bbox="1066 1357 1166 1375">xx1500002967</p> <p data-bbox="1066 1395 1278 1424">M3x8 A2-70 (4 pcs)</p>
8	<p data-bbox="512 1440 1043 1491">Run the cables down through the center hole of axis 1, in the following order:</p> <ul data-bbox="544 1491 1031 1697" style="list-style-type: none"> <li data-bbox="544 1491 903 1523">• Signal cables (Spot welding) <li data-bbox="544 1523 655 1554">• Hoses <li data-bbox="544 1554 1031 1637">• Make a check that the signal cables and hoses do not end up between the motor cables. <li data-bbox="544 1637 1031 1697">• Make a check that the cables and hoses do not cross each other. 	 <p data-bbox="1066 1711 1166 1729">xx1500002968</p>

2 Installation

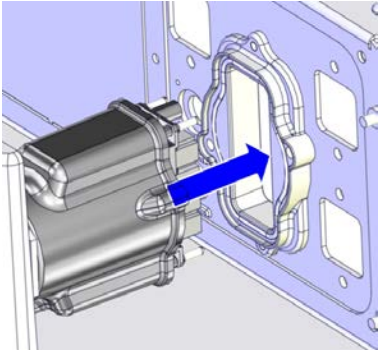
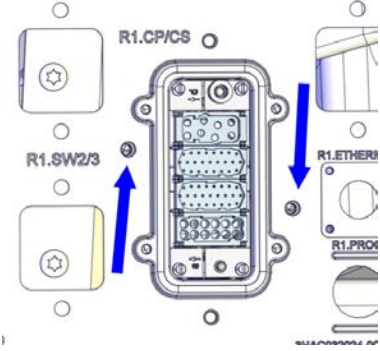
2.2.10.2 Fitting the cable package IRBDP MH LI

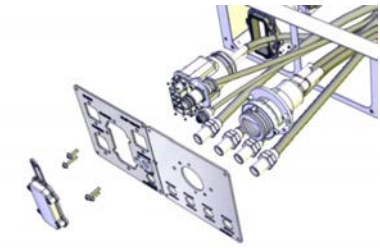

Continued

	Action	Note
9	Fit the R1.CP/CS cable to the customer plate.	 <p>xx1400001142</p>
10	Secure the R1.CP/CS connector.	 <p>xx1400001143</p> <p>M6x25 A2-70 (2 pcs)</p>
11	<p>Connect the rest of the cable and hose connectors to the customer plate.</p> <p> CAUTION</p> <p>Do not tighten the brass couplings for water and air with excessive force.</p> <p> CAUTION</p> <p>Make sure that no cables or hoses are twisted or strained. Reroute if necessary.</p> <p> CAUTION</p> <p>If the M12 Ethernet connector is not tightened correctly, there is a risk that the connector can loosen and the cable shield gets disconnected, which will require retightening with the correct torque tools.</p> <p>For secure connection, always tighten at the knurled screw with correct torque and by using proper torque tool, e.g. M12 dynamometric screwdriver SW15 (09 99 000 0646 (article number at Harting Technology Group)).</p>	<p>Tightening torque:</p> <ul style="list-style-type: none"> • Brass coupling 1/2": 31 Nm. • Stainless steel coupling 1/2": 49 Nm. • Brass coupling 3/8": 17 Nm. • Mixed metals: Use the lower tightening torque value of the two metals. <p>Always apply Molykote P1900 to stainless steel couplings and apply if needed for couplings of mixed metals or brass.</p> <p>Tightening torque, Ethernet M12: 0.6 Nm.</p>  <p>xx1200000088</p>

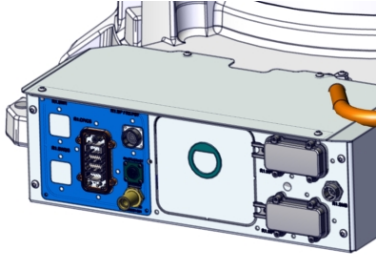
Continues on next page

	Action	Note
12	Refit the rear cover plate.	 <p>xx1500002969</p>

Fitting the cable package

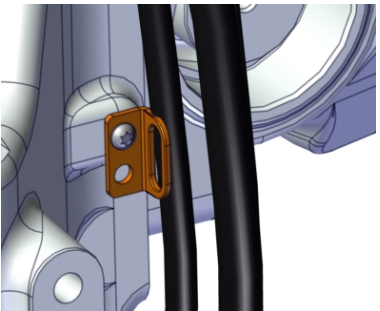
	Action	Note
1	 <p>DANGER</p> <p>Turn off all:</p> <ul style="list-style-type: none"> • electric power supply • air pressure supply <p>to the robot, before starting the repair work on the robot.</p>	
2	 <p>CAUTION</p> <p>The cable package is sensitive to mechanical damage. Handle it with care in order to avoid damaging the cabling or the connectors.</p>	
3	Fasten cable package with a velcro strap.	 <p>xx1500001593</p>
4	Push the cable package through the inside of the lower arm.	
5	Fasten the cable package to the robot cabling inside the lower arm with velcro straps.	Velcro straps (4 pcs)

Continues on next page



2 Installation

2.2.10.2 Fitting the cable package IRBDP MH LI

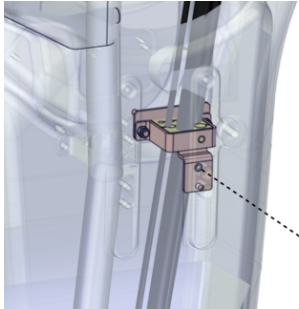
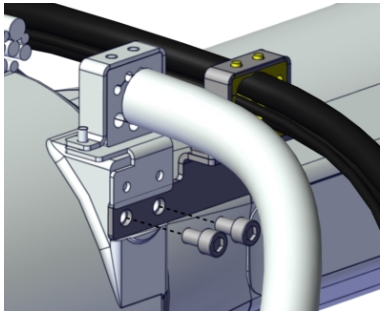
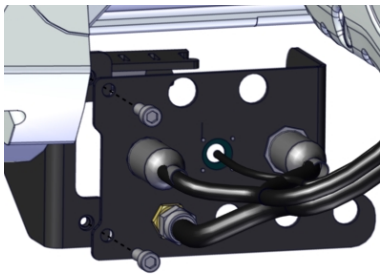
Continued

	Action	Note
6	Fasten the rubber clamp with bracket inside the lower arm.	 xx1500001594 Screw M6x16 (1 pcs)
7	Fasten the rubber clamp with bracket on the upper arm.	 xx1500001595
8	Fasten the connection plate to mounting plate axis 3.	 xx1500001596 Screw M10x25 8.8-A3F (2 pcs)

Continues on next page

	Action	Note
9	<p>Fasten the connectors and the water couplings on the connector plate.</p> <p> CAUTION</p> <p>Do not tighten the brass couplings for water and air with excessive force.</p> <p> CAUTION</p> <p>If the M12 Ethernet connector is not tightened correctly, there is a risk that the connector can loosen and the cable shield gets disconnected, which will require retightening with the correct torque tools.</p> <p>For secure connection, always tighten at the knurled screw with correct torque and by using proper torque tool, e.g. M12 dynamometric screwdriver SW15 (09 99 000 0646 (article number at Harting Technology Group)).</p>	<p>Tightening torque:</p> <ul style="list-style-type: none"> • Brass coupling 1/2": 31 Nm. • Stainless steel coupling 1/2": 49 Nm. • Brass coupling 3/8": 17 Nm. • Mixed metals: Use the lower tightening torque value of the two metals. <p>Always apply Molykote P1900 to stainless steel couplings and apply if needed for couplings of mixed metals or brass.</p> <p>Tightening torque, Ethernet M12: 0.6 Nm.</p>

2 Installation

2.2.11.1 Fitting the attachments of IRBDP MH3 UI

2.2.11 Installation of IRBDP MH3 UI

2.2.11.1 Fitting the attachments of IRBDP MH3 UI

Location of the cable package attachments

IRB 6650S-200/3.0, -190/3.0 LID, - 125/3.5 and -100/3.5 LID

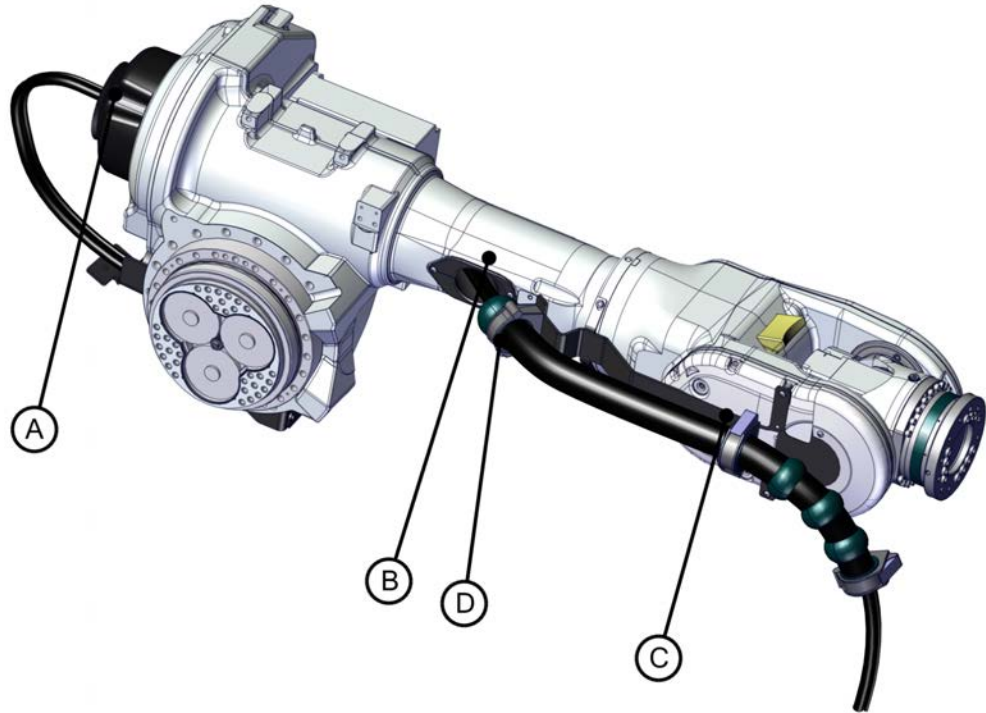

xx1500001544

A	Cover
B	Insert and tube (inside upper arm)
C	Upper arm bracket
D	Gripping clamp

Continues on next page

IRB 6650S 90/3.9

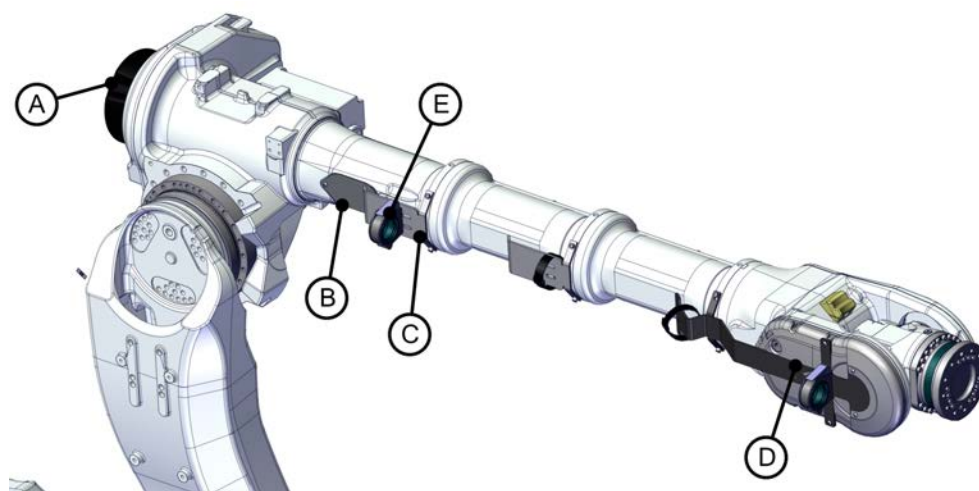

xx1500002031

A	Cover
B	Insert and tube (inside upper arm)
C	Bracket right (2 pcs)
D	Upper arm bracket
E	Gripping clamp

Required parts

Spare part	Article number	Note
Material set IRBDP MH3 UI	3HAC054863-001	

Required tools and equipment

Equipment	Article number	Note
Standard toolkit		Content is defined in section Standard toolkit on page 357 .

Required consumable

Consumable	Article number	Note
Locking liquid	3HAB7116-1	Loctite 243 For locking attachment screws.

Fitting the cable package attachments - IRBDP MH3 UI

Use this procedure to fit the cable attachments of the cable package IRBDP MH3 UI.

	Action	Note
1	Move the robot to a suitable position for fitting the cable attachments on the upper arm.	

Continues on next page

2 Installation

2.2.11.1 Fitting the attachments of IRBDP MH3 UI

Continued

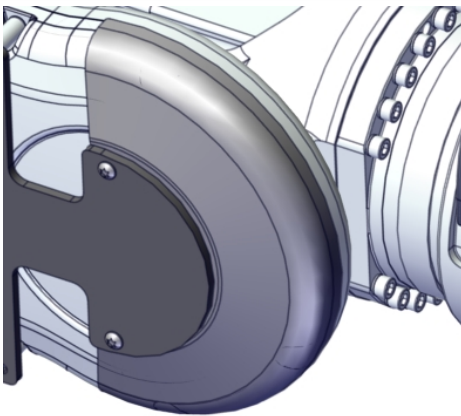
	Action	Note
2	<p> DANGER</p> <p>Turn off all:</p> <ul style="list-style-type: none">• electric power supply• air pressure supply <p>to the robot, before starting the repair work on the robot.</p>	
3	Fasten the cover on the upper arm bracket.	 <p>xx1500000931</p> <p>Screw M6x10 (2 pcs) and Nut M6</p>

Continues on next page

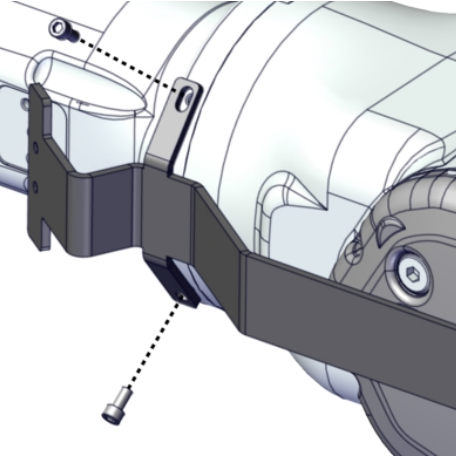
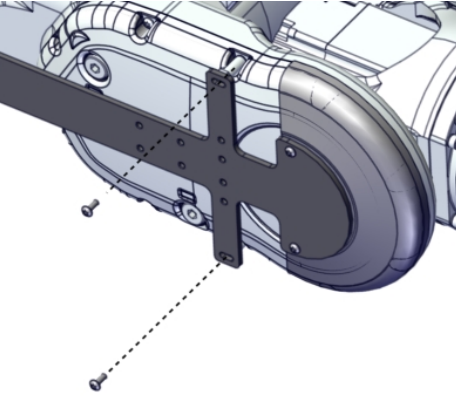
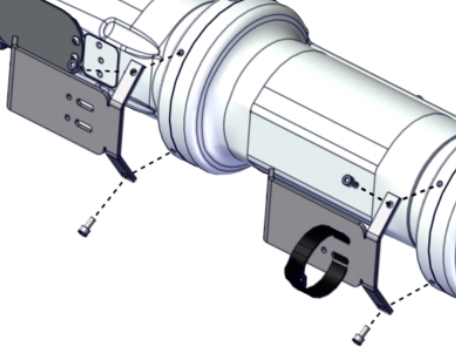
	Action	Note
4	Fasten the upper arm bracket. Lock screws with locking liquid (Loctite 243).	 <p data-bbox="975 772 1082 790">xx150000929</p> <p data-bbox="975 808 1206 837">Screw M8x16 (2 pcs)</p>  <p data-bbox="975 1249 1082 1267">xx150000930</p> <p data-bbox="975 1285 1206 1350">M6 Distance sleeve Screw M6x16 (2 pcs)</p>
5	IRB 6650S-90/3.9: Fasten the bracket right. Lock screws with locking liquid (Loctite 243).	 <p data-bbox="975 1758 1082 1776">xx1500002032</p> <p data-bbox="975 1794 1206 1823">Screw M8x16 (4 pcs)</p>
6	Place washer 2 holes.	

Continues on next page

2 Installation

2.2.11.1 Fitting the attachments of IRBDP MH3 UI

Continued

	Action	Note
7	Fasten gripping clamp. Lock screws with locking liquid (Loctite 243).	 <p data-bbox="941 757 1050 772">xx1500001577</p> <p data-bbox="941 790 1173 817">Screw M8x16 (2 pcs)</p>
8	Place washer 2 holes.	
9	IRB 6650S-200/3.0, -190/3.0 LID, - 125/3.5 and -100/3.5 LID: Fasten gripping clamp. Lock the screws with locking liquid (Loctite 243).	 <p data-bbox="941 1328 1050 1344">xx1500001578</p> <p data-bbox="941 1361 1173 1388">Screw M8x16 (2 pcs)</p>
10	IRB 6650S-90/3.9: Fasten gripping clamp. Lock the screws with locking liquid (Loctite 243).	 <p data-bbox="941 1798 1050 1814">xx1500002033</p> <p data-bbox="941 1832 1173 1859">Screw M8x16 (2 pcs)</p>

Continues on next page

Fitting insert, tube and cover

Use this procedure to fit the insert, the tube and the cover.

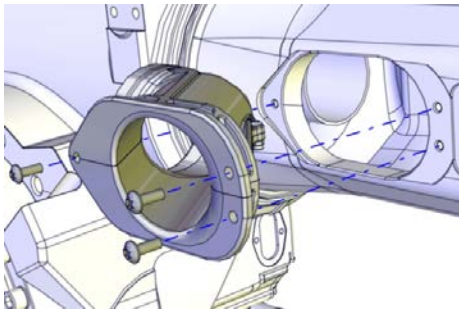
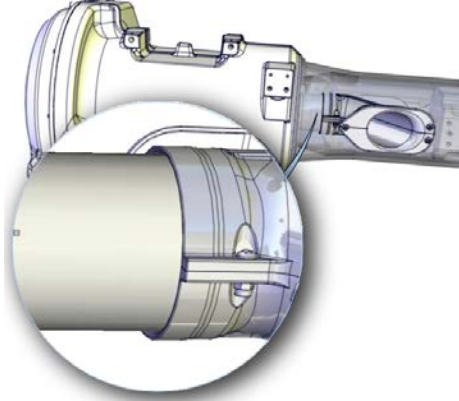
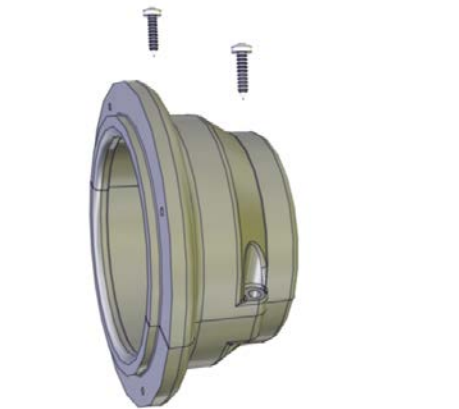

	Action	Note
1	Fit the insert. Lock screws with locking liquid (Loctite 243).	 <p>xx120000042</p> <p>Screw, M6x16 8.8-A2F (3 pcs)</p>
2	Insert the tube into the arm tube and fit it into the insert.	 <p>xx120000043</p>
3	Mount the two parts of the tube guiding ring.	 <p>xx1200000162</p> <p>Pan head screw ST3.9x16 (2 pcs).</p>

Continues on next page

2 Installation

2.2.11.1 Fitting the attachments of IRBDP MH3 UI

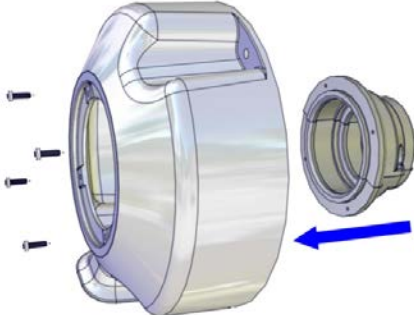
Continued

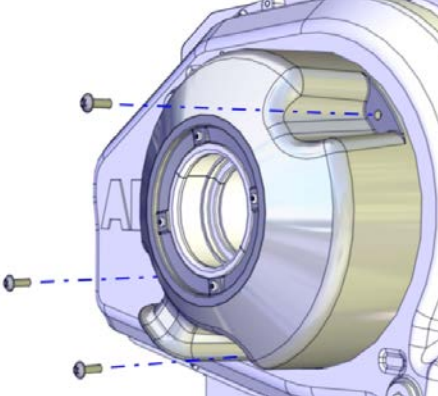
	Action	Note
4	Fit the tube guiding ring in the cover.	 <p data-bbox="941 667 1050 685">xx120000044</p> <p data-bbox="941 703 1401 734">Screw, Pan head screw ST3.9x16 (4 pcs).</p>
5	<p data-bbox="464 748 933 857">Fit the cover, with the tube guiding ring, on the tube and secure it to the armhouse cover. Lock screws with locking liquid (Loctite 243).</p> <p data-bbox="464 875 528 931"> Note</p> <p data-bbox="464 947 903 1003">Check that the tube is fitted correctly in both ends, when fitting the cover.</p>	 <p data-bbox="941 1151 1050 1169">xx120000045</p> <p data-bbox="941 1187 1369 1218">Screws, M6x16 quality 8.8-A2F (3 pcs)</p>

2.2.11.2 Fitting the cable package IRBDP MH3 UI

Location of the cable package

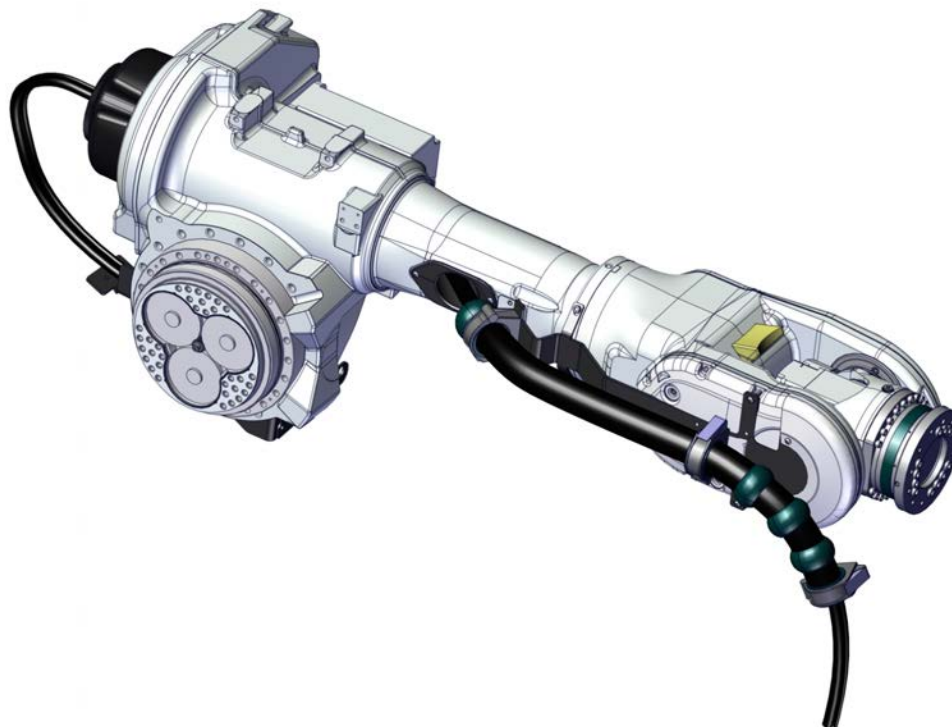

xx1500001579

Required parts

Spare part	Article number	Note
Cable package IRBDP MH3 UI	See DressPack cable package IRBDP MH3 UI on page 379	

Required tools and equipment

Equipment	Article number	Note
Standard toolkit		Content is defined in section Standard toolkit on page 357 .

Required consumable

Consumable	Article number	Note
Locking liquid	3HAB7116-1	Loctite 243 For locking attachment screws.

Continues on next page

2 Installation





2.2.11.2 Fitting the cable package IRBDP MH3 UI

Continued

Fitting the cable package IRBDP MH3 UI

Use this procedure to fit the cable package **IRBDP MH3 UI**.

Route the cable package - Upper arm

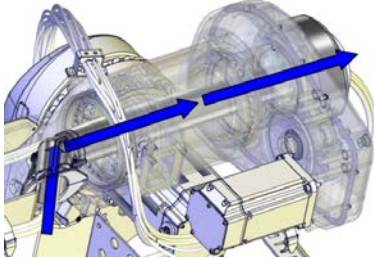

	Action	Note
1	Move the robot to a comfortable working position.	
2	 DANGER Turn off all: <ul style="list-style-type: none"> • electric power supply • air pressure supply to the robot, before starting the repair work on the robot.	
3	 CAUTION The cable package is sensitive to mechanical damage. Handle it with care in order to avoid damaging the cabling or the connectors.	
4	 Tip This procedure is best done by two persons working together - one pushing cabling and hoses into the tube and the other pulling them out at the wrist.	
5	Carefully push the cable package into the insert, through the tube and out in the back of the arm housing.  Tip The following order is preferable: <ol style="list-style-type: none"> 1 Cables 2 Hoses 3 Weld cables (where applicable) 	 <small>xx1400000095</small>

Apply cable grease

It is necessary to apply cable grease on the cable package inside the tube.

	Action	Note
1	Carefully pull the cable package out 10 to 15 centimeters longer than the final assembly position.	

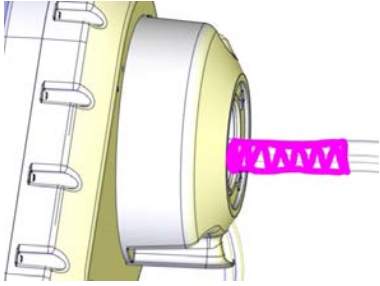
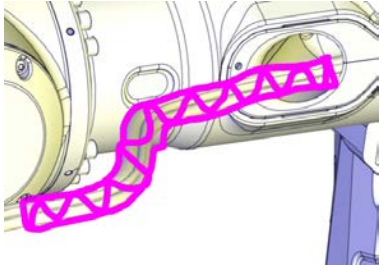
Continues on next page

	Action	Note
2	Apply grease on the highlighted area.	 xx1400001389
3	Carefully push the cable package back into the tube and out through the insert until the area where grease was applied, is visible and able to reach.	
4	Apply grease on the highlighted area, so that the cable package inside the tube is covered with cable grease all the way through.	 xx1400001390
5	Carefully push the cable package back in through the insert and into its mounting position in the tube.	
6	 Note Make sure the cables and hoses are not twisted through the upper arm.	

Apply cable grease

It is necessary to apply cable grease on the cable package inside the tube.

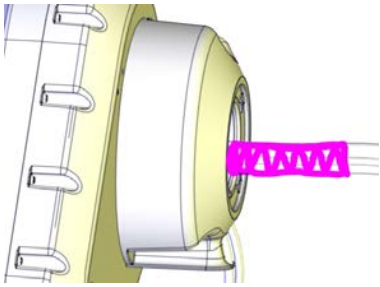

	Action	Note
1	Carefully pull the cable package out 10 to 15 centimeters longer than the final assembly position.	
2	Apply grease on the highlighted area.	 xx1400001389

Continues on next page

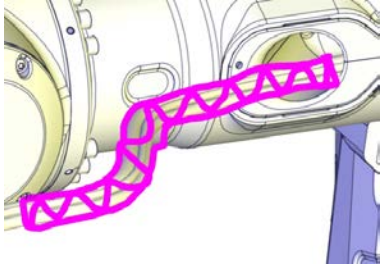

2 Installation

2.2.11.2 Fitting the cable package IRBDP MH3 UI



Continued

	Action	Note
3	Carefully push the cable package back into the tube and out through the insert until the area where grease was applied, is visible and able to reach.	
4	Apply grease on the highlighted area, so that the cable package inside the tube is covered with cable grease all the way through.	 xx1400001390
5	Carefully push the cable package back in through the insert and into its mounting position in the tube.	
6	 Note Make sure the cables and hoses are not twisted through the upper arm.	

Connecting and fitting on the upper arm

	Action	Note
1	 DANGER Turn off all: <ul style="list-style-type: none"> • electric power supply • air pressure supply to the robot, before starting the repair work on the robot.	
2	 CAUTION The cable package is sensitive to mechanical damage. Handle it with care in order to avoid damaging the cabling or the connectors.	

Continues on next page

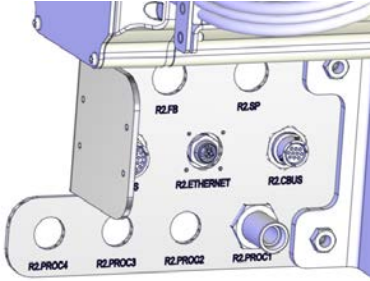
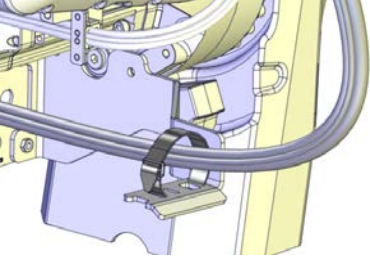
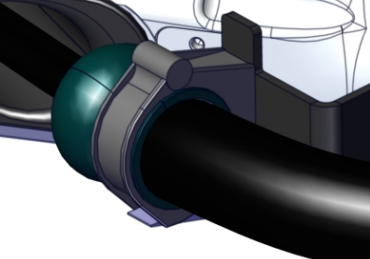
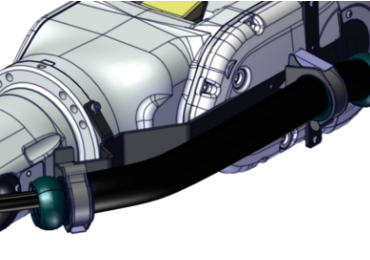
	Action	Note
3	<p>Connect the cable package to the connection plate.</p> <p> CAUTION</p> <p>Do not tighten the brass couplings for water and air with excessive force.</p> <p> CAUTION</p> <p>If the M12 Ethernet connector is not tightened correctly, there is a risk that the connector can loosen and the cable shield gets disconnected, which will require retightening with the correct torque tools.</p> <p>For secure connection, always tighten at the knurled screw with correct torque and by using proper torque tool, e.g. M12 dynamometric screwdriver SW15 (09 99 000 0646 (article number at Harting Technology Group)).</p>	<p>Tightening torque:</p> <ul style="list-style-type: none"> • Brass coupling 1/2": 31 Nm. • Stainless steel coupling 1/2": 49 Nm. • Brass coupling 3/8": 17 Nm. • Mixed metals: Use the lower tightening torque value of the two metals. <p>Always apply Molykote P1900 to stainless steel couplings and apply if needed for couplings of mixed metals or brass.</p> <p>Tightening torque, Ethernet M12: 0.6 Nm.</p>  <p>xx1400000225</p>
4	<p>Fasten the cable package to the bracket with a strap.</p>	 <p>xx1400000096</p>
5	<p>Fasten the cable package in the gripping clamps on the upper arm bracket.</p>	 <p>xx1500001582</p>  <p>xx1500001581</p>

Continues on next page

2 Installation

2.2.11.2 Fitting the cable package IRBDP MH3 UI

Continued

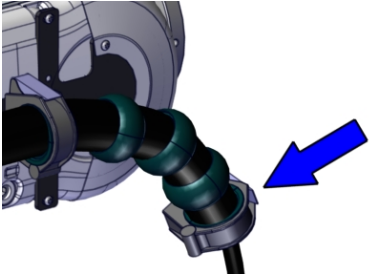
	Action	Note
6	The gripping clamp at the front shall be fitted on equipment used by the customer.	 <p data-bbox="1029 593 1141 616">xx1500001583</p>

2.2.12 Inspection, DressPack lower arm

General

In order to ensure adequate life of the equipment, it is vital that the cables and hoses are properly installed and operated correctly, with their movement patterns well within the acceptable limits.

This procedure describes how to inspect the DressPack lower arm installation in this regard.

Inspecting the process cable package

	Action	Note
1	<p><i>Do not bend</i> any cable or hose excessively!</p>  Note Make sure no cables or hoses are twisted.	Minimum bending radius is approximately 10x the cable or hose diameter.
2	Make sure all cables straps are tight enough to prevent the cable package from moving in any undesired way.	
3	Make sure the cable package is properly connected at the connection plate as well as at the robot base.	
4	Make sure no hoses or cables, or parts thereof, touch any part of the robot structure in a way that may cause wear.	
5	Make sure all cables and hoses move smoothly together during operation and that no part of the cable package moves in a different pattern.	
6	Make sure that cables, hoses or packages do not rub against <i>any sharp corner of something</i> (not just the robot itself)!	
7	Make sure all connection points are well tightened and sealed in order to avoid leaks.	

Inspecting the attachments and brackets

	Action	Note
1	Make sure that all cable clamps securing the process cable package and protective hose are tightened correctly.	Tightening torques are specified: <ul style="list-style-type: none"> • For <i>standard tightening torques</i> - See tightening torque table in chapter References. • For <i>non standard tightening torques</i> see chapter <i>Installation</i>.

2 Installation

2.2.13 Inspection, DressPack upper arm

2.2.13 Inspection, DressPack upper arm

General

In order to ensure adequate life of the equipment, it is vital that the cables and hoses are properly installed and operated correctly, with their movement patterns well within the acceptable limits.

This procedure describes how to inspect the DressPack upper arm installation in this regard.

Procedure, general

	Action	Note
1	Inspect all attachments, brackets and any other hardware securing or guiding the protective hose.	Described in section Attachments and brackets on page 166 .
2	Inspect the process cable package.	Detailed in section Cables and hoses on page 167 .
3	Make sure all cables and hoses are securely fixed and connected.	Detailed in section Securing and connecting on page 168 .

Attachments and brackets

This section details each inspection to be carried out, not necessarily in any particular order unless stated.



Note

This procedure is not applicable to cable package IRBDP MH3 UE , IRBDP SW6 UI and IRBDP MH6 UI.

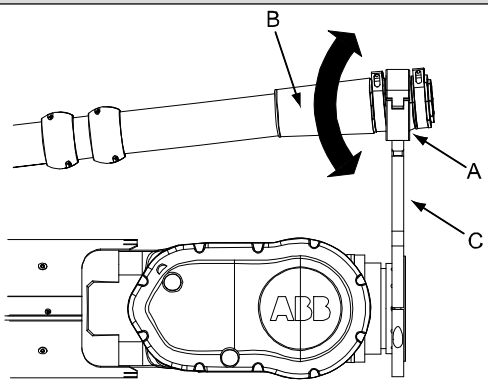
	Action	Note
1	<p>Make sure the sliding surfaces of the slide sleeve has not been damaged.</p> <p>Check this with normal hand force:</p> <ul style="list-style-type: none"> • grab hold of the package • pull and turn to make sure that the package is free to slide. 	 <p>xx0300000199</p> <ul style="list-style-type: none"> • A: Slide sleeve slide surface • B: Hose reinforcement • C: Process cable support, axis 6



Note

A damaged surface may potentially prevent the cable package from rotating causing excessive wear.

Continues on next page

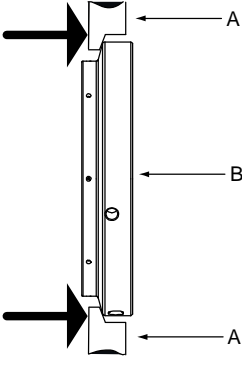
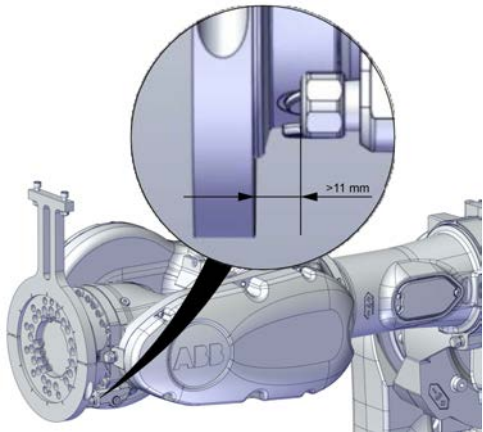
	Action	Note
2	<p>Check that the <i>process cable support, axis 6</i> is pushed forward completely against the <i>turning disk, axis 6</i>. See illustration!</p>	 <p>xx0400001040</p> <p>Parts:</p> <ul style="list-style-type: none"> • A: Process cable support, axis 6 • B: Turning disk, axis 6
3	<p>Check the tightening torque.</p>	<p>Correct tightening torque: 70 Nm.</p>
4	<p>Check the angle of the <i>process cable support, axis 6</i> in relation to the movement pattern of the cable package. If required, change the position of the process cable support, axis 6 to ensure that the cable package does not get stretched or bent excessively.</p>	
5	<p>Make sure that it is enough space between the <i>process cable support, axis 6</i> (or other tools) and the calibration pin axis 6. This in order to be able to remove the <i>Protection cover</i>. See illustration!</p>	 <p>xx2100000126</p>

Cables and hoses

The procedure below details each inspection to be carried out, not necessarily in any particular order if not so stated.

	Action	Note
1	<p><i>Do not bend</i> any cable or hose excessively.</p>	<p>Minimum bending radius is approximately 10 x the cable or hose diameter.</p>
2	<p>Make sure no cables or hoses are twisted.</p>	

Continues on next page

2 Installation

2.2.13 Inspection, DressPack upper arm

Continued

	Action	Note
3	<p>Make sure that all hoses and cables to gun or gripper are long enough to avoid stretching during any part of the cycle.</p>  Note (Not applicable to cable package IRB-DP MH3 UE) When cutting the cables/hoses, make sure the length is sufficient between slide sleeve to fixation point (strap) on the tool, to enable cable and hoses to rotate in the process cable support, axis 6, as detailed above!	<p>(Not applicable to cable package IRBDP MH3 UE) Do not strap closer than 400 mm from slide sleeve.</p>
4	<p>Make sure that cables are clamped with straps in a way that there is no movement at connectors.</p>	<p>Use only wide straps or velcro straps in order not to damage the cables and hoses.</p>
5	<p>Make sure that no hoses or cables, or parts thereof, touch any part of the robot structure in a way that may cause wear.</p>	
6	<p>Make sure that no hoses or cables, or parts thereof, touch any part of the <i>surrounding equipment</i> in a way that may cause wear.</p>	
7	<p>Make sure all cables and hoses move smoothly together during operation and that no part of the cable package moves in a different pattern.</p>	
8	<p>Make sure cable loops are not allowed to swing as the robot runs.</p>	

Securing and connecting

The procedure below details each inspection to be carried out, not necessarily in any particular order unless stated.

	Action	Note
1	<p>Make sure that all cable clamps securing the process cable package and protective hose are tightened correctly.</p>	<p>Tightening torques are specified:</p> <ul style="list-style-type: none"> • For standard tightening torques - See tightening torque table in chapter References. • For <i>non standard tightening torques</i> - See Installation chapter.
2	<p>Make sure all cable straps are tight enough to prevent the cable package from moving in any undesired way.</p>  Note The cable straps/ties should not be too narrow. It may damage the cables/hoses.	

Continues on next page

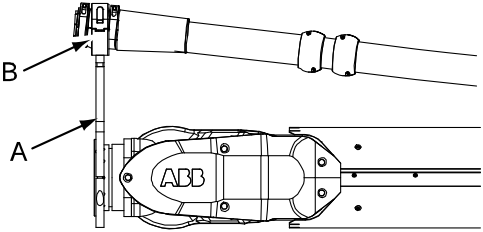
	Action	Note
3	<p>(Not applicable to cable package IRB-DP MH3 UE)</p> <p><i>Do not strap, or in any other way secure, the cables/hoses to the process cable support, axis 6 in a way that may prevent the assembly to swivel properly.</i></p> <p>Whenever strapping the cables/hoses to the process cable support, axis 6, make sure the assembly is free to swivel properly.</p> <p> Note</p> <p>Do not strap closer than 400 mm from the slide sleeve!</p>	 <p>xx0300000072</p> <ul style="list-style-type: none"> • A: Process cable support, axis 6 • B: Slide sleeve
4	<p>When securing cables and hoses with cable ties: <i>never</i> overtighten the ties! This may damage the equipment.</p>	
5	<p>Make sure that the cable package have been properly connected at the connection plate, axis 3 on the rear of the upper arm as well as at the tool on the robot turning disk.</p>	
6	<p>Make sure all connection points are well tightened and sealed in order to avoid leaks.</p>	
7	<p>Make sure the weight of the cable package is secured to the tool in order to avoid straining the connectors!</p>	

2 Installation

2.2.14 Expected lifetime of the integrated DressPack cable package

2.2.14 Expected lifetime of the integrated DressPack cable package

General

The expected lifetime of the integrated DressPack cable package is dependent of the actual robot cycle. For the robot upper arm (axes 4, 5, and 6) the combination of the robot axes gives influence on lifetime. Below are recommendations for programming given as well as expected lifetime based on long term tests as well as normal spot welding application cycles.

Expected life time

If the robot cycle is done according to the recommendations above a lifetime could be expected for a normal spot welding cycle in two shift production, as shown in the table.

4-6 years	All DressPack cable packages listed in this manual <i>except</i> IRBDP SW6 and IRBDP MH6.
3-6 years	IRBDP SW6 and IRBDP MH6.

2.3 DressPack adjustments

2.3.1 Adjustments of - IRBDP MH2 UE and IRBDP SW2 UE



Note

This section is **not** applicable to cable package IRBDP MH3 UE! How to adjust cable package IRBDP MH3 UE is detailed in [Adjustments of the cable package - IRBDP MH3 UE on page 175](#).

General

The instructions below details how to adjust the routing of the DressPack upper arm to avoid reducing its life.

How to adjust the tension arm unit, see section [Adjusting tension arm unit on page 322](#).

Hose reinforcement

Should the hose reinforcement get strained under the upper arm during the work cycle, the following tips may assist in alleviating the problem.

The figure shows a DressPack upper arm fitted to an IRB 6600, but the problem is identical to all robot types.

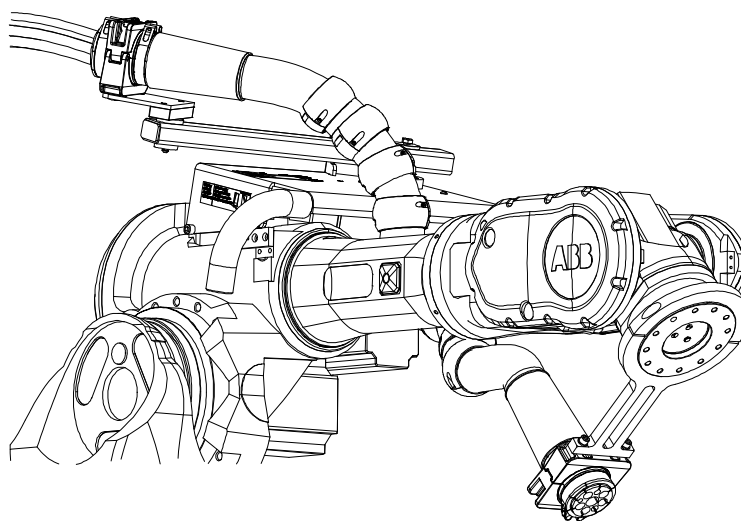

xx0500001560

	Action	Note
1	Either, try changing the robot position or orientation at the particular position to reduce the angle of axis 5 in combination of axis 6,	
2	or rotate the attachment angle of the process cable support, axis 6 slightly.	

Continues on next page

2 Installation

2.3.1 Adjustments of - IRBDP MH2 UE and IRBDP SW2 UE

Continued

Hoses and cables too long around the wrist

If the DressPack upper arm is too long, the hose loop may get obstructed or caught by the brackets or any other equipment.

How to adjust the upper arm MH dressing cable package IRBDP MH3 is detailed in section [Adjustments of the cable package - IRBDP MH3 UE on page 175](#).

The figure shows a DressPack upper arm fitted to an IRB 6600, but the problem is identical to all robot types.

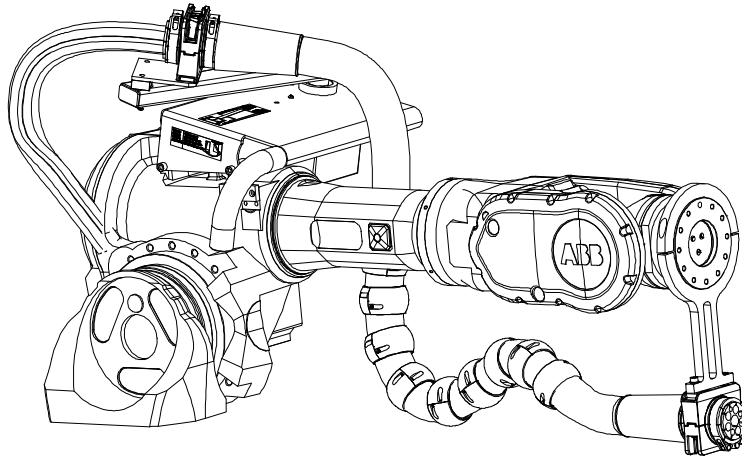

xx0500001561

	Action	Note
1	<p>Make sure that the position of the ball joint housing is correct.</p> <p>The position of the ball joint housing and the cable package may differ, depending on the robot model. See illustration and table below.</p> <p>Position 1:</p> <ul style="list-style-type: none"> • IRB 6650S - 3.0 • IRB 7600 - 2.3 • IRB 7600 - 2.55 <p>Position 2:</p> <ul style="list-style-type: none"> • IRB 6650S - 3.5 <p>Position 3:</p> <ul style="list-style-type: none"> • IRB 7600 - 2.8 • IRB 7600 - 3.5 	<p>xx0500001578</p> <p>Parts:</p> <ul style="list-style-type: none"> • A: Ball joint housing • B: Tension arm

Continues on next page

	Action	Note
2	Adjust the tension arm unit to reduce the slack in the hose package Adjusting tension arm unit on page 322 .	
3	If this does not solve the problem, the robot movements must be limited. If this is not done, there is a substantial risk of damaging the hose/cable package.	
4	After changing the DressPack upper arm installation, it needs to be inspected to ensure the function.	Detailed in section Adjustments of - IRBDP MH2 UE and IRBDP SW2 UE on page 171 .

Hoses and cables too long

The hoses and cables at the end of the hose package are too long. The length should allow any required robot movement without stretching and also allow rotation inside the process cable support, axis 6.

The figure shows a DressPack upper arm fitted to an IRB 6600, but the problem is identical to all robot types.

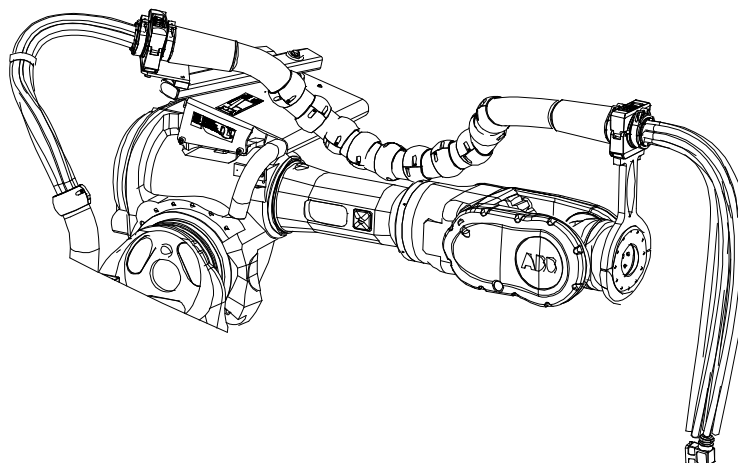

xx0500001575

	Action	Note
1	<p>Cut the weld cable and hoses to a length that will suit the application before making any connections to the tool.</p> <p> Note</p> <p>Do not pull back the cables and hoses through the protective hose!</p> <p>Note the length of cables and hoses to make it easier for a later change to a spare cable package.</p>	<p>Do not cut the hoses and weld cable too short. During programming it can be necessary to adjust the position of the process cable support, axis 6.</p>

Continues on next page

2 Installation



2.3.1 Adjustments of - IRBDP MH2 UE and IRBDP SW2 UE

Continued

	Action	Note
2	Loop the excess hoses and cables in a way that enables securing them with <i>cable clamps</i> or similar allowing quick replacement of the package.	When securing cables and hoses with cable ties: <i>never</i> overtighten the ties! This may damage the equipment.  Note Use wide cable ties!
3	After changing the DressPack upper arm installation, it needs to be inspected to ensure the function.	Detailed in section Adjustments of - IRBDP MH2 UE and IRBDP SW2 UE on page 171 .

Process cable package too short

If the DressPack is too short, unacceptable strain may be put on the cables, hoses and connectors.

	Action	Note
1	Make sure the correct cable package is used.  Note Remember that different lengths of the upper arm require different cable packages!	Check the Adjustments of - IRBDP MH2 UE and IRBDP SW2 UE on page 171 section for article numbers!
2	Check that the position of the ball joint housing is correct.	
3	Make sure all attachments and supports are <i>fitted correctly</i> .	Detailed in section Adjustments of - IRBDP MH2 UE and IRBDP SW2 UE on page 171 . If required adjust their fitting positions! When securing cables and hoses with cable ties: <i>never</i> overtighten the ties! This may damage the equipment.
4	 Note If the DressPack cable package appears to be fitted too strained, the reason can be that the tension arm is adjusted too tightly.	How to adjust the tension arm is detailed in section Adjusting tension arm unit on page 322 .
5	After changing the DressPack upper arm installation, it needs to be inspected to ensure the function.	Detailed in section Preventive inspection, DressPack upper arm on page 212 .

2.3.2 Adjustments of the cable package - IRBDP MH3 UE

Overview



The procedure below details how to adjust the routing of the upper arm cable package -IRBDP MH3 UE, in order to avoid reducing its life.

Hoses and cables too long around the wrist

Depending on robot version and gripper design, the length of the protection hose, air hose and/or cables may need to be adjusted. Protection hose and air hose can be cut to the desired length.

It is possible to fit the protection hose in different positions, depending on where the gripping clamp is fitted on the bracket. There are more than one position to fit the gripping clamp.

The procedure below details how to fit gripping clamp and protection hose in the different positions.

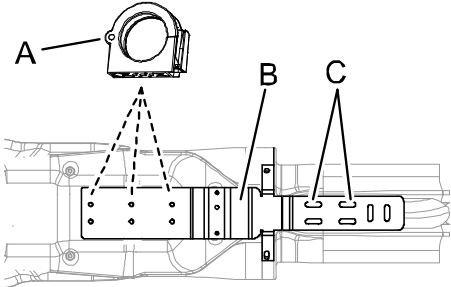
	Action	Note
1	 DANGER Turn off all: <ul style="list-style-type: none"> • electric power supply • hydraulic pressure supply • air pressure supply to the robot, before entering the robot working area.	
2	 CAUTION The cable package is sensitive to mechanical damage. They must be handled with care, especially the connectors, in order to avoid damaging them.	
3	Fit the <i>gripping clamp</i> in the best suitable position on the <i>bracket</i> . Choose one of the positions shown in the figure.	 <p>xx0700000389</p> <p>Parts:</p> <ul style="list-style-type: none"> • A: Gripping clamp • B: Bracket left • C: Position for straps
4	If the cables are too long it is possible to pull them back out of the protection hose and then put them in a loop. Fit the cables with the enclosed <i>straps</i> on the bracket.	Shown in the figure above.

2 Installation

2.3.3 Adjustment of the cable package - IRBDP SW5 CE (DressPack Basic)

2.3.3 Adjustment of the cable package - IRBDP SW5 CE (DressPack Basic)





Overview

The position of the ball joint housing and gripping clamp on the adjustable bracket is different depending on robot version.

Adjustment procedure

The procedure below details how to adjust the position of the process cable package DressPack Basic before commissioning.

It is possible to place the ball joint housing and gripping clamp in different positions on the adjustable bracket in order to get the smoothest movements possible of the process cable package and preventing premature wear.

	Action	Note
1	 DANGER Turn off all: <ul style="list-style-type: none">• electric power supply• hydraulic pressure supply• air pressure supply to the robot, before entering the robot working area.	
2	 CAUTION The cable package is sensitive to mechanical damage. They must be handled with care, especially the connectors, in order to avoid damaging them.	
3	Fit the <i>ball joint housing and gripping clamp</i> on the adjustable bracket with the brackets and attachment screws.	Detailed in section Fitting the attachments of IRBDP SW5 CE (DressPack Basic) on page 101 .  Note Place the axis 6 bracket in a way that axis 5 doesn't press the DressPack against the robot arm in any position or movement in the working programs of the robot.  Note Do not secure the attachment screws completely at this point! It must still be possible to move the ball joint housing and gripping clamp back and forth on the adjustable bracket.
4	Fit the process cable package in the ball joint housing and gripping clamp.	Detailed in section Fitting the cable package IRBDP SW5 CE (DressPack Basic) on page 109 .

Continues on next page

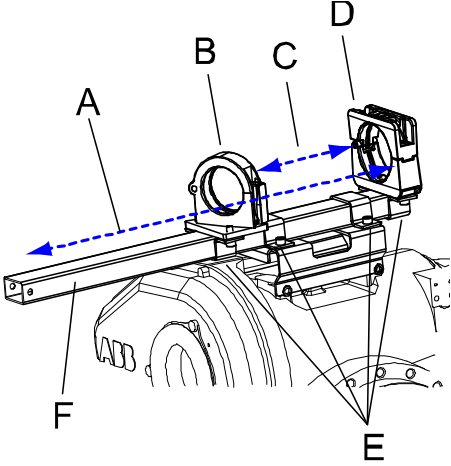
	Action	Note
5	<p>Adjust the process cable package in a way that it will move smoothly in accordance to the movements of the robot's axes 4, 5 and 6, by putting the <i>ball joint housing</i> and <i>gripping clamp</i> in the best position possible. The adjustable bracket is also possible to put in different positions depending on robot model and variant.</p> <p>Adjust the position of the <i>adjustable bracket</i> in order to adapt the position of the process cable package to the different arm lengths and movements of the wrist and upper arm. The adjustable bracket shall be fitted as far back as possible in order to allow the DressPack to follow the movements of the robot arm. The process cable package must not be wound hard against the robot arm at any given position while the robot is moving.</p> <p> Note</p> <p>If the process cable package is fitted wrongly it will result in too much rubbing against the robot. This will result in increased wear of the cable package.</p>	 <p>xx0800000109</p> <p>Parts:</p> <ul style="list-style-type: none"> • A: Position can be adjusted depending on which cable package is used. • B: Gripping clamp • C: Distance and position can be adjusted depending on robot model and version, and cable package. • D: Ball joint housing • E: Bracket • F: Adjustable bracket
6	<p>When fitting the <i>gripping clamp</i> on the adjustable bracket, fit it behind the <i>ball joint housing</i>.</p>	<p>Pos C in the figure above.</p>
7	<p>Secure the attachment screws of the brackets holding the ball joint housing and gripping clamp.</p> <p>Lock screws with locking liquid.</p>	
8	<p>If there is any exceptional strain on the process cable package, adjust the position of the ball joint housing and gripping clamp further.</p>	
9	<p>Depending on the actual fitting of the DressPack and the robot program, the protective sleeves may have to be moved in order to prevent the protection hose from being worn directly while rubbing against robot and/or wrist.</p>	

2 Installation

2.3.4 Inspection during programming and test-running

2.3.4 Inspection during programming and test-running

General

In order to ensure adequate life of the equipment, it is vital that the cables and hoses are properly installed and operated correctly, with their movement patterns well within the acceptable limits.

Checking the cable package at the upper arm

This procedure describes how to inspect the DressPack upper arm installation during programming and test-running the complete installation the very first times.

IRBDP MH2 UE, IRBDP SW2 UE, IRBDP SW2 CE and IRBDP SW5 CE

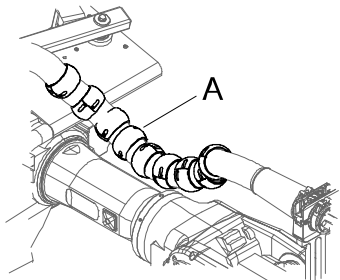
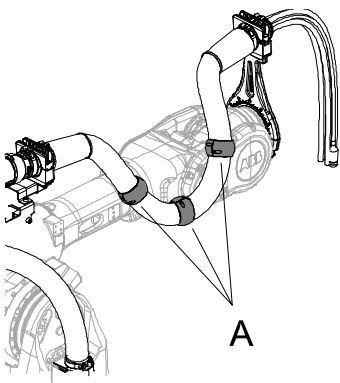
	Action	Note
1	Inspect the DressPack upper arm installation.	See section Inspection, DressPack upper arm on page 166 .
2	Check the position of the process cable support axis 6, in relation to the final movement pattern of the robot wrist.	Make a note of where the process cable support axis 6 was finally positioned to make it easier to replace it in the future.
3	<p>Check the positions of the <i>protective sleeves</i> after programming is completed.</p> <p>Place these where they prevent the protective hose from rubbing against the robot's upper arm as much as possible.</p> <p>If required, additional protective sleeves may be fitted.</p>	<p>IRBDP MH2 UE, IRBDP SW2 UE & IRBDP SW2 CE</p>  <p>xx0500001441</p> <p>IRBDP SW5 CE</p>  <p>xx0800000084</p> <p>Parts:</p> <ul style="list-style-type: none"> A: Protective sleeves <p>Make a note of where the protective sleeves were finally positioned to make it easier to replace them in the future.</p>

Continues on next page

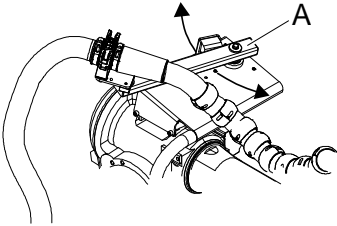
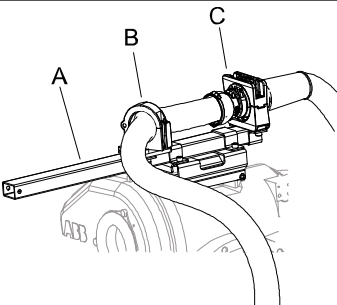
	Action	Note
4	Check the operating cycle of the robot, to make sure the movement pattern of the wrist does not cause extensive wear or strain of the cable package.	If required, re-program the robot movement pattern!
5	Large rotating movements of the upper arm (axes 4 and 6 combined) may cause twisting of the DressPack.	When programming such movements, we recommend that the rotating movement of axis 6 is ordered before that of axis 4. This reduces the risk of damaging the DressPack upper arm.
6	Make sure the upper arm protective hose <i>does not get flattened</i> during rotating upper arm movements.	Flattening indicates an overstressed hose and <i>increases</i> the risk of damaging the DressPack upper arm.
7	Make sure no combined rotating movements of axes 5 and 6 causes collisions between the <i>cables/hoses</i> or the <i>process cable support axis 6</i> and the upper arm. Such movements may also cause excessive bending of cables or hoses.	Collisions and excessive bending will <i>increase</i> the risk of damaging the equipment. Minimum bending radius: 10 x cable/hose diameter.
8	Valid for IRBDP MH2 UE, IRBDP SW2 UE & IRBDP SW2 CE. Make sure that the movements of the <i>tension arm</i> are smooth and do not jerk the cable package.	 <p>xx0500001442</p> <p>Parts:</p> <ul style="list-style-type: none"> • A: Tension arm (seen from above) <p>If required, increase or reduce the amount of spring tension of the tension arm unit.</p>
9	Valid for IRBDP SW5 CE Make sure all movements at the <i>adjustable bracket with ball joint housings and gripping clamp</i> are smooth and do not jerk the process cable package.	 <p>xx0800000085</p> <p>Parts:</p> <ul style="list-style-type: none"> • A. Adjustable bracket • B: Gripping clamp • C: Ball joint housing
10	IRB 7600 only: Make sure the process cable package does not rub against the sides of the wrist more than absolutely necessary.	The rubbing may result in the cable getting stuck. When the package is released, the retracting unit may snap back, potentially causing damage to the equipment.
11	If any of the actions recommended above, cause you to change the DressPack installation, it must be reinspected.	See section Inspection, DressPack upper arm on page 166 .

Continues on next page

2 Installation

2.3.4 Inspection during programming and test-running

Continued

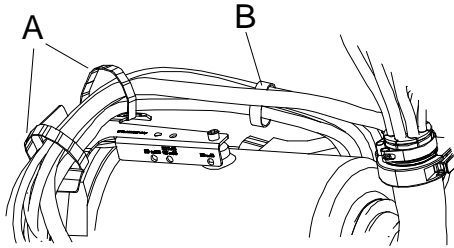
	Action	Note
12	<p>Make sure that the <i>velcro straps</i> is not too tight. The cables should be able to twist individually.</p> <p>The <i>straps</i> shall be tight!</p>	 <p>xx0500001792</p> <p>Parts:</p> <ul style="list-style-type: none"> • A: Straps • B: Velcro straps
13	<p>Make sure that no parts of the DressPack are in contact with the surroundings.</p>	

IRBDP MH3 LE & IRBDP MH3 UE

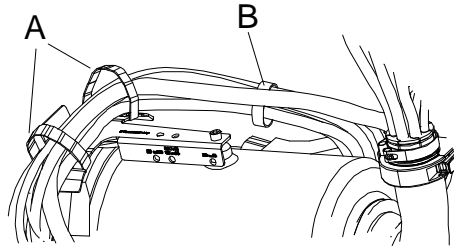
	Action	Note
1	<p>Inspect the DressPack upper arm installation before programming and test-running.</p>	<p>See section Inspection, DressPack upper arm on page 166.</p>
2	<p>Make a check of the operating cycle of the robot, to make sure that the movement pattern of the wrist does not cause extensive wear or strain of the cable package.</p>	<p>If required, re-program the robot movement pattern.</p>
3	<p>Make sure that the upper arm protective hose does not get flattened during rotating upper arm movements.</p>	<p>Flattening indicates an overstressed hose and increases the risk of damaging the DressPack upper arm.</p>
4	<p>IRB 7600</p> <p>Make sure the process cable package does not rub against the sides of the wrist more than absolutely necessary.</p>	<p>The rubbing may result in the cable getting stuck. When the package is released, the retracting unit may snap back, potentially causing damage to the equipment.</p>
5	<p>If any of the actions recommended above, causes a change of the DressPack installation, it must be reinspected.</p>	<p>See section Inspection, DressPack upper arm on page 166.</p>
6	<p>Make sure that the <i>velcro straps</i> is not too tight. The cables should be able to twist individually.</p> <p>The <i>straps</i> shall be tight.</p>	 <p>xx0500001792</p> <p>Parts:</p> <ul style="list-style-type: none"> • A: Straps • B: Velcro straps
7	<p>Make sure that no parts of the DressPack are in contact with the surroundings.</p>	

Continues on next page

2.3.4 Inspection during programming and test-running

Continued

	Action	Note
8	<p>(Only applicable if process cable support axis 6 is used!)</p> <p>Make sure no combined rotating movements of axes 5 and 6 causes collisions between the cables/hoses or the process cable support axis 6, and the upper arm. Such movements may also cause excessive cable/hose bending.</p>	<p>Collisions and excessive bending will increase the risk of damaging the equipment.</p> <p>Minimum bending radius: 10x cable/hose diameter.</p>

Checking the DressPack at the lower arm

This instruction describes how to inspect the DressPack lower arm installation during programming and test-running the complete installation the very first times.

	Action	Note
1	Inspect the DressPack lower arm installation before programming and test-running.	See section Inspection, DressPack lower arm on page 165
2	Check the operating cycle of the robot, to make sure the movement pattern of the robot does not cause extensive wear or straining on the cable package.	If required, re-program the robot movement pattern!
3	If any of the actions recommended above, causes changes of the DressPack lower arm installation, it must be reinspected.	See section Inspection, DressPack lower arm on page 165

2 Installation

2.4.1 DressPack - arm load parameters and LoadId

2.4 DressPack armload parameters

2.4.1 DressPack - arm load parameters and LoadId

General

A DressPack is adding load to the robot. If the arm and tool loads are not stated correctly, this will affect the behavior and the wear of the robot.



Note

The extra weight of the DressPack products will affect the arm load data and the performance of the robot. The effect differs depending on which type of DressPack product being used.



Note

The "Add to tool data" shall only be used when stating the effect of the DressPack on tool load manually.

Coordinate system definitions

Coordinate system definitions when defining arm loads.

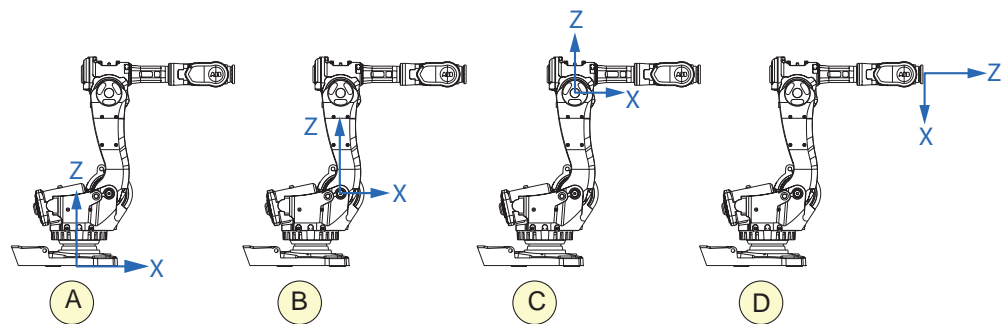

xx0500001893

A	Frame - axis 1
B	Lower arm - axis 2 (Z is in the lower arm direction)
C	Upper arm - axis 3 (X is in the upper arm direction)
D	Tool

Arm load parameters for spot welding

Arm load parameters for IRBDP SW2 and IRBDP SW5

The following table specifies values for DressPack for Spot Welding.

Frame axis 1	MassX [kg]	Mass CenterX [m]	Mass CenterY [m]	Mass CenterZ [m]
IRB 6650S - 200/3.0	9.0	0.080	-0.550	0.465
IRB 6650S - 190/3.0 LID	9.0	0.080	-0.550	0.465
IRB 6650S - 125/3.5	9.0	0.080	-0.550	0.465

Continues on next page

IRB 6650S - 100/3.5 LID	9.0	0.080	-0.550	0.465
Lower arm - axis 2	Mass [kg]	Mass CenterX [m]	Mass CenterY [m]	Mass CenterZ [m]
IRB 6650S - 200/3.0	13.1	0	-0.550	0.550
IRB 6650S - 190/3.0 LID	13.1	0	-0.550	0.550
IRB 6650S - 125/3.5	13.1	0	-0.550	0.550
IRB 6650S - 100/3.5 LID	13.1	0	-0.550	0.550
Upper arm - axis 3	Mass [kg]	Mass CenterX [m]	Mass CenterY [m]	Mass CenterZ [m]
IRB 6650S - 200/3.0	53.5	0.085	0.114	0.286
IRB 6650S - 190/3.0 LID	53.5	0.085	0.114	0.286
IRB 6650S - 125/3.5	55.1	0.133	0.111	0.287
IRB 6650S - 100/3.5 LID	55.1	0.133	0.111	0.287

If Tool load is entered manually the following mass shall be added to tooldata tload.

Add to tool data	Mass [kg]	Mass CenterX [m]	Mass CenterY [m]	Mass CenterZ [m]
IRB 6650S - 200/3.0	9.4	-0.212	0	0
IRB 6650S - 190/3.0 LID	9.4	-0.212	0	0
IRB 6650S - 125/3.5	9.4	-0.212	0	0
IRB 6650S - 100/3.5 LID	9.4	-0.212	0	0

Arm load parameters for IRBDP SW6 Lean ID

These tables show the values for the cable package IRBDP SW6 - Spot welding.

Frame - axis 1	Mass [kg]	Mass CenterX [m]	Mass CenterY [m]	Mass CenterZ [m]
IRB 6650S	9	0.080	0.550	0.465
Lower arm - axis 2	Mass [kg]	Mass CenterX [m]	Mass CenterY [m]	Mass CenterZ [m]
IRB 6650S - 200/3.0	6.4	0.025	0.496	0.831
IRB 6650S - 190/3.0 LID	6.4	0.025	0.496	0.831
IRB 6650S - 125/3.5	6.4	0.025	0.496	0.831
IRB 6650S - 100/3.5 LID	6.4	0.025	0.496	0.831
Upper arm - axis 3	Mass [kg]	Mass CenterX [m]	Mass CenterY [m]	Mass CenterZ [m]
IRB 6650S - 200/3.0	16.5	0.042	0.064	0.069
IRB 6650S - 190/3.0 LID	16.5	0.042	0.064	0.069
IRB 6650S - 125/3.5	17.0	0.042	0.064	0.069
IRB 6650S - 100/3.5 LID	17.0	0.042	0.064	0.069

Continues on next page

2 Installation

2.4.1 DressPack - arm load parameters and LoadId

Continued

Upper arm - axis 4	Mass [kg]	Mass CenterX [m]	Mass CenterY [m]	Mass CenterZ [m]
IRB 6650S - 200/3.0	13.2	0.959	0.201	0.199
IRB 6650S - 190/3.0 LID	13.2	0.959	0.201	0.199
IRB 6650S - 125/3.5	13.7	1.209	0.191	0.199
IRB 6650S - 100/3.5 LID	13.7	1.209	0.191	0.199

If Tool load is entered manually the following mass shall be added to tooldata tload.

Add to tool data	Mass [kg]	Mass CenterX [m]	Mass CenterY [m]	Mass CenterZ [m]
IRB 6650S - 200/3.0	3.1	0	0	0.099
IRB 6650S - 190/3.0 LID	3.1	0	0	0.099
IRB 6650S - 125/3.5	3.1	0	0	0.099
IRB 6650S - 100/3.5 LID	3.1	0	0	0.099



Note

These values reflect the standard mounting of the Process bracket, pointing straight upwards in the robot calibration position. If the mounting is changed, the X, Y and Z values must be changed correspondingly.

Arm load parameters for material handling

Arm load parameters for IRBDP MH

The following table specifies values for DressPack for Material handling.

Frame axis 1	Mass [kg]	Mass CenterX [m]	Mass CenterY [m]	Mass CenterZ [m]
IRB 6650S - 200/3.0	5.9	0.080	-0.550	0.465
IRB 6650S - 190/3.0 LID	5.9	0.080	-0.550	0.465
IRB 6650S - 125/3.5	5.9	0.080	-0.550	0.465
IRB 6650S - 100/3.5 LID	5.9	0.080	-0.550	0.465

Lower arm - axis 2	Mass [kg]	Mass CenterX [m]	Mass CenterY [m]	Mass CenterZ [m]
IRB 6650S - 200/3.0	10.4	0	-0.550	0.653
IRB 6650S - 190/3.0 LID	10.4	0	-0.550	0.653
IRB 6650S - 125/3.5	10.4	0	-0.550	0.653
IRB 6650S - 100/3.5 LID	10.4	0	-0.550	0.653

Upper arm - axis 3	Mass [kg]	Mass CenterX [m]	Mass CenterY [m]	Mass CenterZ [m]
IRB 6650S - 200/3.0	42.4	0.072	0.116	0.286
IRB 6650S - 190/3.0 LID	42.4	0.072	0.116	0.286
IRB 6650S - 125/3.5	43.0	0.104	0.115	0.286
IRB 6650S - 100/3.5 LID	43.0	0.104	0.115	0.286

Continues on next page

If Tool load is entered manually the following mass shall be added to tooldata tload.

Add to tool data	Mass [kg]	Mass CenterX [m]	Mass CenterY [m]	Mass CenterZ [m]
IRB 6650S - 200/3.0	8.2	-0.212	0	0
IRB 6650S - 190/3.0 LID	8.2	-0.212	0	0
IRB 6650S - 125/3.5	8.2	-0.212	0	0
IRB 6650S - 100/3.5 LID	8.2	-0.212	0	0

Arm load parameters for IRBDP MH3

The following table specifies values for DressPack for Material handling.

Frame axis 1	Mass [kg]	Mass CenterX [m]	Mass CenterY [m]	Mass CenterZ [m]
IRB 6650S	5.9	0.080	-0.550	0.465

Lower arm - axis 2	Mass [kg]	Mass CenterX [m]	Mass CenterY [m]	Mass CenterZ [m]
IRB 6650S - 200/3.0	3.7	0.028	-0.242	0.845
IRB 6650S - 190/3.0 LID	3.7	0.028	-0.242	0.845
IRB 6650S - 125/3.5	3.7	0.028	-0.242	0.845
IRB 6650S - 100/3.5 LID	3.7	0.028	-0.242	0.845
IRB 6650S - 90/3.9	3.7	0.028	-0.242	0.845

Upper arm - axis 3	Mass [kg]	Mass CenterX [m]	Mass CenterY [m]	Mass CenterZ [m]
IRB 6650S - 200/3.0	14.1	0.025	-0.067	0.087
IRB 6650S - 190/3.0 LID	14.1	0.025	-0.067	0.087
IRB 6650S - 125/3.5	14.4	0.020	-0.067	0.087
IRB 6650S - 100/3.5 LID	14.4	0.020	-0.067	0.087
IRB 6650S - 90/3.9	14.1	0.025	-0.067	0.087

Upper arm - axis 4	Mass [kg]	Mass CenterX [m]	Mass CenterY [m]	Mass CenterZ [m]
IRB 6650S - 200/3.0	10.2	0.990	-0.177	0.188
IRB 6650S - 190/3.0 LID	10.2	0.990	-0.177	0.188
IRB 6650S - 125/3.5	10.4	1.240	-0.167	0.188
IRB 6650S - 100/3.5 LID	10.4	1.240	-0.167	0.188
IRB 6650S - 90/3.9	10.7	1.490	-0.157	0.188

Arm load parameters for IRBDP MH6

The following table specifies values for DressPack for Material handling.

Frame axis 1	Mass [kg]	Mass CenterX [m]	Mass CenterY [m]	Mass CenterZ [m]
IRB 6650S	5.9	0.080	-0.550	0.465

Continues on next page

2 Installation

2.4.1 DressPack - arm load parameters and LoadId

Continued

Lower arm - axis 2	Mass [kg]	Mass CenterX [m]	Mass CenterY [m]	Mass CenterZ [m]
IRB 6650S - 200/3.0	3.7	0.028	-0.242	0.845
IRB 6650S - 190/3.0 LID	3.7	0.028	-0.242	0.845
IRB 6650S - 125/3.5	3.7	0.028	-0.242	0.845
IRB 6650S - 100/3.5 LID	3.7	0.028	-0.242	0.845

Upper arm - axis 3	Mass [kg]	Mass CenterX [m]	Mass CenterY [m]	Mass CenterZ [m]
IRB 6650S - 200/3.0	14.1	0.025	-0.067	0.087
IRB 6650S - 190/3.0 LID	14.1	0.025	-0.067	0.087
IRB 6650S - 125/3.5	14.4	0.020	-0.067	0.087
IRB 6650S - 100/3.5 LID	14.4	0.020	-0.067	0.087

Upper arm - axis 4	Mass [kg]	Mass CenterX [m]	Mass CenterY [m]	Mass CenterZ [m]
IRB 6650S - 200/3.0	11.4	0.875	-0.223	0.199
IRB 6650S - 190/3.0 LID	11.4	0.875	-0.223	0.199
IRB 6650S - 125/3.5	11.7	1.225	-0.213	0.199
IRB 6650S - 100/3.5 LID	11.7	1.225	-0.213	0.199

If Tool load is entered manually the following mass shall be added to tooldata tload.

Add to tool data	Mass [kg]	Mass CenterX [m]	Mass CenterY [m]	Mass CenterZ [m]
IRB 6650S - 200/3.0	2.1	0	0	-0.099
IRB 6650S - 190/3.0 LID	2.1	0	0	-0.099
IRB 6650S - 125/3.5	2.1	0	0	-0.099
IRB 6650S - 100/3.5 LID	2.1	0	0	-0.099



Note

These values reflect the standard mounting of the Process bracket, pointing straight upwards in the robot calibration position. If the mounting is changed, the X, Y and Z values must be changed correspondingly.

Default arm loads

For Lean ID robots, default arm loads are set for axis 1-4. These are set according to the values for the cable package IRBDP SW6 - Spot welding. If any other values should be used (for example IRBDP MH6 - Material handling), the arm loads must be changed manually.



Note

No tooldata is set as default. This must be set manually.

Continues on next page

Procedures Step 1 - Arm load data

How to define the *Arm load* data is described in *Operating manual - IRC5 with FlexPendant* or *Operating manual - OmniCore*.

All system parameters are described in *Technical reference manual - System parameters*.

Define the arm loads, typically:

- load:_1
- load:_2
- load:_3

The used arm load is defined for each arm, irb_1, irb_2, and irb_3.

Procedures Step 2 - load identification

It is recommended to use the load identification service routine to define the load data for an individual robot, as this method not only measures the mass but also the inertia of the tool.

Detailed in *Operating manual - IRC5 with FlexPendant* or *Operating manual - OmniCore*.

	Action	Note
1	Check if the cable package prevents movements.	If the cable package prevent the motions.
2	If not: Run the load identification service routine.	The DressPack forces on the wrist will "increase" the load parameters, but this is anyhow a good approximation of the actual load case to be considered by the motion planning functions of the robot.
3	If the cable package prevent the motions: Remove the cable package.	
4	Make the load identification.	
5	Refit the cable package.	
6	Add the DressPack load manually.	See Procedures Step 1 - Arm load data on page 187 .

2 Installation

2.5.1 Installation of DressPack floor

2.5 DressPack floor

2.5.1 Installation of DressPack floor

Configuration and connections of DressPack floor

The DressPack floor is made up of several components. Some of these components are specific to DressPack application, while others are used also in other applications.

The configuration of the components differs between different application types.

Types of application

Some typical applications are specified below:

Type of application	Description	Example of included components
H		Robot, single cabinet controller
S	Pneumatic gun	Robot, single cabinet controller
HS	Material handling and pneumatic gun	Robot, single cabinet controller, pedestal gun
Se	Servo gun	Robot, single cabinet controller
HSe	Material handling and servo gun	Robot, single cabinet controller, pedestal gun

Connection points

The cables and connections points between the components are all detailed and illustrated in the circuit diagram for the current application. See references to the circuit diagrams in [References on page 10](#).

Required equipment

Equipment, etc.	Article number	Note
DressPack floor	For spare part number see chapter: <ul style="list-style-type: none">Spare parts on page 361.	A number of versions are available.
Standard toolkit	3HAC17290-7	The contents are defined in section Toolkits, DressPack on page 357 .



Reference documents

Document	Document number	Note
<i>Circuit diagram - DressPack IRB 6640, IRB 6650S, IRB 7600</i>	3HAC026209-001	

Continues on next page

Installation

The procedure below details how to install the DressPack floor. Also refer to the current circuit diagram according to [References on page 10](#) and the [Spare parts on page 361](#) chapter.

	Action	Note
1	 DANGER Turn off all: <ul style="list-style-type: none"> • electric power supply • hydraulic pressure supply • air pressure supply to the robot, before entering the safe-guarded space.	
2	 CAUTION The cable package is sensitive to mechanical damage. Handle it with care in order to avoid damaging the cabling or the connectors.	
3	Determine which type of installation is to be done. Study the circuit diagram to decide which cables to connect.	The different types are shown in section Configuration and connections of DressPack floor on page 188 .
4	Whenever possible, run all cables/hoses in cable ducts or trenches. Make sure these meet the required standards.	Make sure: <ul style="list-style-type: none"> • no floor weld cable is routed along signal cabling to minimize the risk of interference. • the duct/trench floor is free from sand and other contamination. This is to reduce the risk of damaging the cable insulation. • no cables or hoses rub against any sharp corners which might damage them.
5	Do not bend or twist any cable or hose excessively.	Minimum bending radius is approximately 10x the cable or hose diameter.
6	Make sure all cable straps are tight enough to prevent the cable package from moving in any undesired way.	
7	Select which CP/CS cabling (customer power/customer signals) to be used.	Some versions include industrial buses. See circuit diagram and the Spare parts on page 361 chapter.

Continues on next page

2 Installation

2.5.1 Installation of DressPack floor

Continued

	Action	Note
8	<p>Connect the CP/CS cable to the manipulator and controller cabinet connectors.</p> <p> Note</p> <p>If the M12 Ethernet/PROFINET connector is not tightened correctly, there is a risk that the connector can loosen and the cable shield gets disconnected, which will require retightening with the correct torque tools. For secure connection, always tighten with correct torque and by using proper torque tool, e.g. assembly tool SAC BIT M12-D15 and torque screwdriver TSD 04 SAC with preset torque of 0.4 Nm.</p>	<p>See circuit diagram and the Spare parts on page 361 chapter.</p>
9	<p>If used, connect the split box cable to the water and air unit on the robot and to the spot welding cabinet (if no PROFINET is available) or to the single cabinet controller (if PROFINET is available) <i>connectors</i>.</p>	<p>See circuit diagram and the Spare parts on page 361 chapter.</p>
10	<p>If used, connect the functional ground cable to the robot base and to the spot welding cabinet.</p>	<p>See circuit diagram.</p>

2.5.2 Inspection, DressPack floor

General

In order to ensure adequate life of the equipment, it is vital that the cables and hoses are properly installed and operated correctly, with their movement patterns well within the acceptable limits.

This instruction details how to inspect the DressPack floor installation in this regard.

Procedure, process cable package

This section details each inspection to be carried out, not necessarily in any particular order unless stated.

	Action	Note
1	Make sure that the cable package is properly connected at the robot base as well as at the other end.	
2	Make sure that no hoses or cables, or parts thereof, are routed in such a way that they are subjected to wear, for example hoses being run over by fork lifts etc.	
3	Make sure that no cables or hoses rub against any sharp corners which might damage them.	
4	<p>Make sure all connection points are well tightened and sealed in order to avoid leaks.</p> <p> Note</p> <p>If the M12 Ethernet/PROFINET connector is not tightened correctly, there is a risk that the connector can loosen and the cable shield gets disconnected, which will require retightening with the correct torque tools. For secure connection, always tighten with correct torque and by using proper torque tool, e.g. assembly tool SAC BIT M12-D15 and torque screwdriver TSD 04 SAC with preset torque of 0.4 Nm.</p>	

2 Installation

2.6.1 Installation of Water and air unit

2.6 Water and air unit

2.6.1 Installation of Water and air unit

Overview

This section details how to install the Water and Air unit. The figures show IRB 6700, but the principle is the same for other robot types as well.

Location of the Water and Air unit

The Water and Air unit is located on top of the robot base, as shown in the figure.

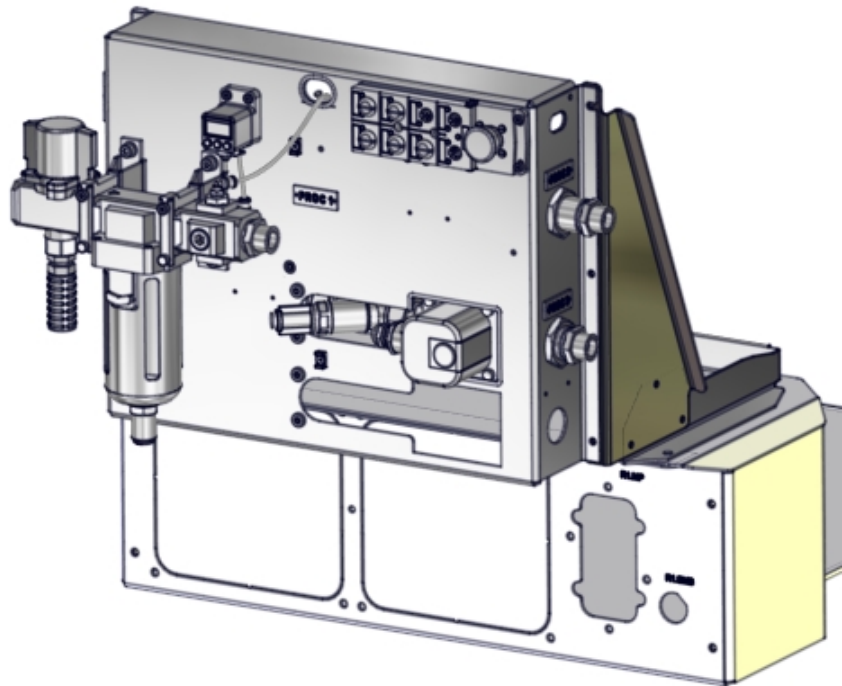

xx1300002321

General technical data

The table below shows technical data of the water and air pressure:

Parameter	Value
Water operating pressure	Max. 0.6 MPa / 87 PSI
Air operating pressure	Max. 1.0 MPa / 145 PSI

Continues on next page

The table below shows technical data for water and air quality:

Parameter	Value
Water quality	Normal filtered industrial water quality, 80 to 100 mesh.
Air quality	Use clean air. When there is excessive condensate, install a device that will eliminate water, such as a dryer or water separator (Drain Catch) on the inlet side of the air filter.

Required equipment

Equipment, etc	Article number	Note
Water and Air unit	For spare part number see chapter: <ul style="list-style-type: none"> Spare parts on page 361. 	
Standard toolkit, DressPack	3HAC17290-7	The contents are defined in section Toolkits, DressPack on page 357.

Reference documents

Document	Document number	Note
<i>Circuit diagram - DressPack for spot-welding SWC IRC5 M2004</i>	3HAC026208-001	Valid for all robots without PROFINET.
<i>Circuit diagram - DressPack SWC IRC5 Design 2014 PROFINET</i>	3HAC044736-001	Valid for all robots with option 782-13 Bosch MFDC PROFINET.

Installation of Water and air unit

The procedure below details how to install the Water and Air unit on the robot base.

	Action	Note
1	 DANGER Turn off all: <ul style="list-style-type: none"> • electric power supply • water pressure supply • air pressure supply to the robot, before entering the robot working area.	

Continues on next page

2 Installation

2.6.1 Installation of Water and air unit

Continued

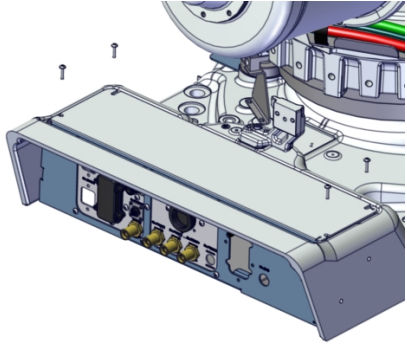
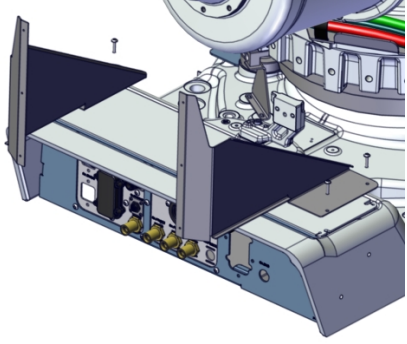
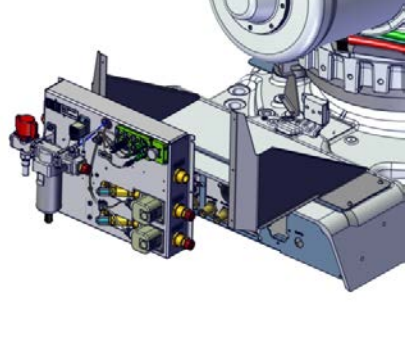
	Action	Note
2	<p>Remove the attachment screws securing the top cover at the base of the robot. Do not remove the top cover!</p> <p> Note</p> <p>Keep the screws! They will be reused when fitting the water and air unit on the top cover.</p>	 <p>xx170000995</p>
3	<p>Fit the bracket using the attachment screws removed earlier.</p>	 <p>xx170000996</p>
4	<p>Fit the water and air unit to the brackets with its attachment screws (Fastite).</p>	 <p>xx170000997</p>

Continues on next page

Connections to Water and air unit

The figure shows the connections at the robot base.

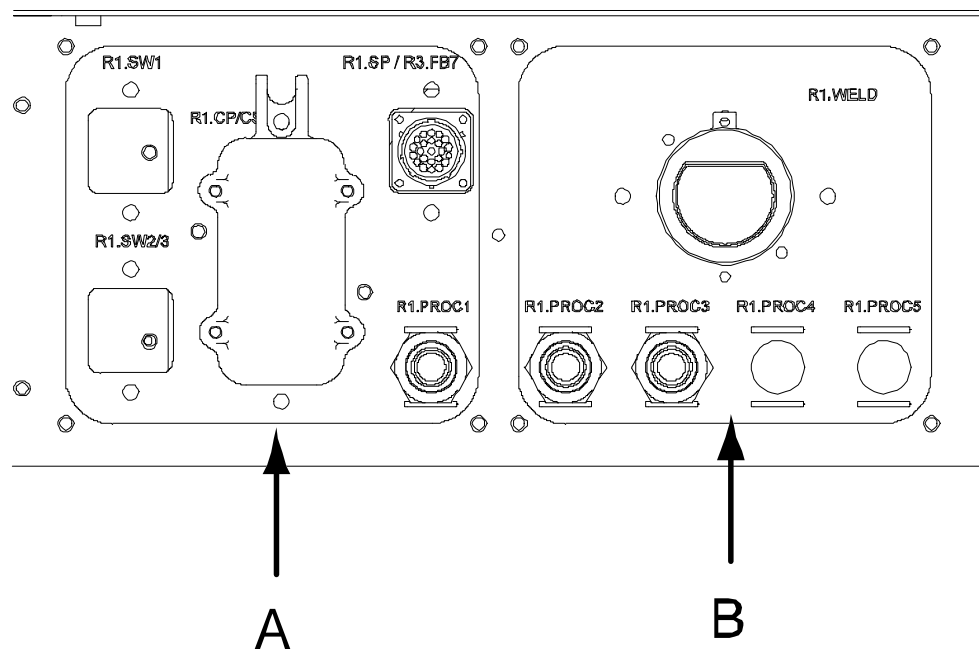

xx0600003178

A	Customer plate
B	Process plate

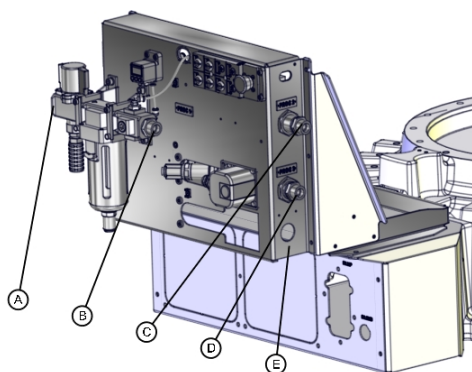

xx1300002326

Item in figure	Connect to:	Function:
A	Shop compressed air supply	
B	PROC1 on robot base	Compressed air supply to robot
C	PROC2 on robot base	Water in circuit
D	PROC3 on robot base	Water return circuit
E	PROC4 on robot base Note! Only the position of this connection is shown in the figure!	Depending on option selected: <ul style="list-style-type: none"> • Second water return • Regulated air

Continues on next page

2 Installation

2.6.1 Installation of Water and air unit

Continued

 <p>CAUTION</p> <p>Do not tighten the brass couplings for water and air with excessive force.</p>	<p>Tightening torque:</p> <ul style="list-style-type: none"> • Brass coupling 1/2": 31 Nm. • Stainless steel coupling 1/2": 49 Nm. • Brass coupling 3/8": 17 Nm. • Mixed metals: Use the lower tightening torque value of the two metals. <p>Always apply Molykote P1900 to stainless steel couplings and apply if needed for couplings of mixed metals or brass.</p>
---	---

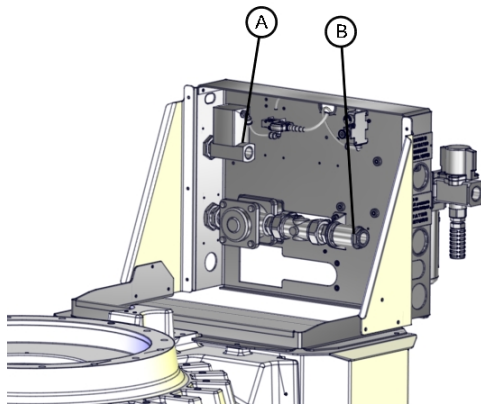

xx1300002327

Item in figure	Connect to:	Function:
A	Shop water supply	
B	Shop water drain Note! In case of a second water return, the water drain connection is moved to the outside of the mounting plate!	

Shop water supply

Use this procedure to connect the Water and Air unit to the shop water supply.

	Action	Note
1	Route the water supply hose through the upper hole in the mounting plate.	
2	Connect the hose to the fitting with a G $\frac{1}{2}$ " thread on the solenoid valve (A).  <p>CAUTION</p> <p>Do not tighten the brass couplings for water and air with excessive force.</p>	

Continues on next page

Shop compressed air supply

Use this procedure to connect the Water and Air unit to the shop compressed air supply.

	Action	Note
1	<p>Connect the air hose to the fitting with a G$\frac{1}{2}$" thread on the air shut off valve (C).</p> <p> CAUTION</p> <p>Do not tighten the brass couplings for water and air with excessive force.</p>	

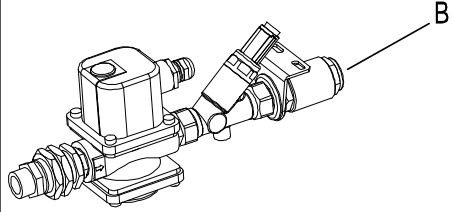

Water drain connection, One water return

Use this procedure to connect the water drain connection with one water return, to the Water and Air unit.

	Action	Note
1	Route the water drain hose through the lower hole in the mounting plate.	
2	<p>Connect the hose to the fitting with a G$\frac{1}{2}$" thread on the check-valve.</p> <p> CAUTION</p> <p>Do not tighten the brass couplings for water and air with excessive force.</p>	 <p>xx0600003348</p> <ul style="list-style-type: none"> • B: Water drain connection, one water return

Water drain connection, Two water return

Use this procedure to connect the water drain connection with two water return, to the Water and Air unit.

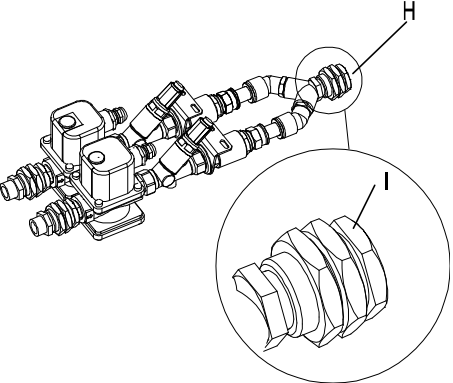
	Action	Note
1	<p>Connect the hose to the <i>bulkhead fitting</i> with a G$\frac{1}{2}$" thread.</p> <p> CAUTION</p> <p>Do not tighten the brass couplings for water and air with excessive force.</p> <p> Note</p> <p>Any rotation of the bulkhead fitting must be avoided when mounting. Hold the <i>outer part of the bulkhead fitting</i> with a suitable tool, in order to prevent rotation.</p>	 <p>xx0600003349</p> <p>Parts:</p> <ul style="list-style-type: none"> • H: Bulkhead fitting • I: Outer part of bulkhead fitting

Continues on next page

2 Installation

2.6.1 Installation of Water and air unit

Continued

Hoses connecting Robot and Water and Air unit

Use this procedure to connect hoses between robot and Water and Air unit.

	Action	Note
1	 CAUTION Do not tighten the brass couplings for water and air with excessive force.	Tightening torque: <ul style="list-style-type: none">• Brass coupling 1/2": 31 Nm.• Stainless steel coupling 1/2": 49 Nm.• Brass coupling 3/8": 17 Nm.• Mixed metals: Use the lower tightening torque value of the two metals. Always apply Molykote P1900 to stainless steel couplings and apply if needed for couplings of mixed metals or brass.
2	Connect Proc 1 on the Water and Air unit with Proc 1 on the robot.	
3	Connect Proc 2 on the Water and Air unit with Proc 2 on the robot.	
4	Connect Proc 3 on the Water and Air unit with Proc 3 on the robot.	
5	Connect Proc 4 on the Water and Air unit with Proc 4 on the robot.	If second water return or regulated air is used.
6	Secure all connectors.	See <i>Tightening torques</i> in section Screw joints on page 353 .

2.6.2 Return water flow control

Overview

The mechanical flow control valve is pre-set at delivery at 8 liter/min (maximum flow).

Settings

The procedure below details how to set the mechanical flow control valve.

	Action	Note
1	Open the solenoid valve on the water inlet.	
2	Water flow is indicated on the scale of the Flow control valve.	
3	Adjust water flow by using the red adjusting knob on the scale of the Flow control valve to the required set flow.	The red adjusting knob is placed on the back of the Water and Air unit.

2 Installation

2.6.3 Return water flow switch setting

2.6.3 Return water flow switch setting



Introduction

The mechanical flow switch is pre-set at delivery to 8 liters/min at 0.2 MPa water pressure.

If the water pressure exceeds 0.2 MPa, the setting cannot be done with the graduation on the window name plate, as the pressure affects the measured flow. Please perform the setting as described in the following procedure.

Settings

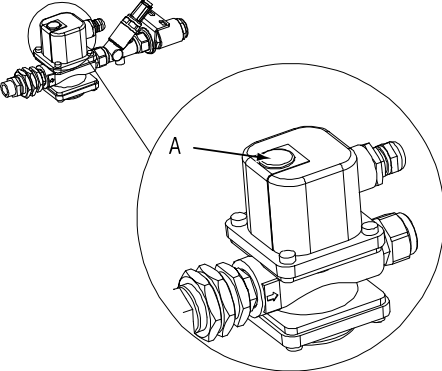
The procedure below details how to set the mechanical flow switch.

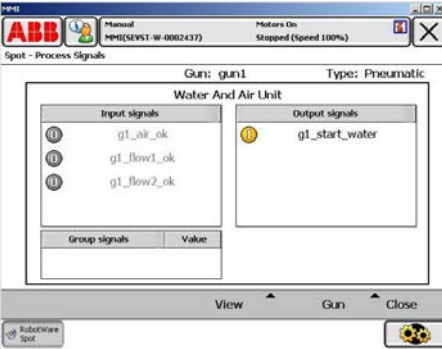
	Action	Note
1	Open the solenoid valve on the water inlet.	
2	Water flow is indicated on the scale of the flow control valve.	
3	Adjust the water flow to the level where the Flow switch shall give alarm. Use the red adjusting knob on the scale of the flow control valve.	See section Return water flow control on page 199 .
4	<p>To adjust the set flow on the mechanical Flow switch, remove the grommet on the upper cover and rotate the flow adjusting gear by using a flat screwdriver.</p> <p>Turning clockwise will increase the set flow and turning counterclockwise will decrease the set flow.</p>	 <p>xx0600003346</p> <p>Parts:</p> <ul style="list-style-type: none"> A: Flow switch
5	<p>Depending on initial value, increase or decrease the set value until the <code>g_flow_ok</code> changes, by observing the <i>Process Signals window</i> on the FlexPendant.</p> <p> Note</p> <p>The indicated flow level may differ from real flow as the flow switch is affected by the water pressure.</p>	 <p>xx0600003355</p> <ul style="list-style-type: none"> Process Signals window
6	Refit the grommet on the flow switch.	

Continues on next page

	Action	Note
7	Increase water flow to desired level by adjusting the flow control valve. Put back the red adjusting knob on the back of the Water and Air unit.	 Note This level shall be higher than the alarm level.

2 Installation

2.6.4 Setting of air pressure switch (only applicable to type S)

2.6.4 Setting of air pressure switch (only applicable to type S)

General

The digital pressure switch monitors the shop floor air pressure.

Settings

The procedure below details how to set the digital pressure switch. The example shows how to set according to the pre-set values. The sensor will set **g1_air_ok** in the robot controller when pressure reaches 0.5 MPa and reset **g1_air_ok** if pressure goes lower than 0.45 MPa.

	Mode	Action	Note
1	Preparation	Make sure that the pressure switch is connected to 12-24 VDC power.	
2	Initialize	In measurement mode, press SET button for two seconds or more.	0
3	Selection of Unit	Press UP or DOWN button until the display matches the figure on the right, then press the SET button.	PA PA indicates MPa.
4	OUT1 Output type Setting	Press UP or DOWN button until display matches the figure on the right, then press the SET button.	1no ("1no" = Output 1 normally open)
5	OUT2 Output type Setting	Ignore and press the SET button.	2n*
6	Response Time Setting	Press UP or DOWN button until display matches the value on the right, then press the SET button.	24
7	Auto/Manual Setting	Press UP or DOWN button until display matches the value on the right, then press the SET button.	ñAn (ñAn indicates manual setting)
8	Value Setting	In measurement mode, press the SET button.	
9	Set Point Value for OUT1(1) Pressure OK goes high	When the display blinks, press UP or DOWN button without pressing the SET button. Press UP or DOWN button until the display matches the value on the right, then press the SET button.	P_1 0.500
10	Set Point Value for OUT1(2) Pressure OK goes low	When the display blinks, press UP or DOWN button without pressing the SET button. Press UP or DOWN button until the display matches the value on the right, then press the SET button.	P_2 0.450
11	Set Point Value for OUT2(1)	Ignore and press the SET button.	P/n3
12	Set Point Value for OUT2(2)	Ignore and press the SET button.	P/n4
13		The pressure switch changes to measurement mode. All settings are completed.	0
14	Zero Clear Function	Press UP and DOWN buttons simultaneously for about 2 seconds, under atmospheric pressure.	0

Continues on next page

2.6.4 Setting of air pressure switch (only applicable to type S)

Continued

Pre-set values

Parameter	Pre-set value
Unit specification	MPa
Hysteresis mode	Normally open
Response time	24 ms
High pressure P_1	0.5 MPa
Low pressure P_2	0.05 MPa

2 Installation

2.6.5 Setting of electrical proportional valve (option)

2.6.5 Setting of electrical proportional valve (option)

Introduction

The electrical proportional valve is available as an option.

The output pressure from the proportional valve is set by a voltage input signal, 0 - 10 VDC.

The output pressure range is 0.005 - 0.9 MPa.

I/O configuration

The following has to be done in order to configure the system to automatically feed the electrical proportional valve with 24 V only, when there is a sufficient air pressure indicated by the air pressure switch. If there is not enough pressure, the electrical proportional valve works continuously and the lifetime may be shortened.

The related input and output is **gx_air_ok** and **gx_epvalve_on**, where x represents the actual gun. The example below shows the setting for gun 1.

	Action	Note
1	Create a digital output signal named g1_epvalve_on on unit SWBOARD1 and unit mapping 14.	
2	Create a cross connection between g1_air_ok and g1_epvalve_on .	

Setting

Normally the pre-set values are used. But if other settings are desired, do as described below.

The procedure below details how to set the proportional valve.

Mode		Action	Note
Preparation	1	Make sure that the 12-24 VDC power is connected.	
Release key locking	2	The indication <i>Loc</i> flashes on LED by pushing the DOWN key for two seconds or more. The key locking function is released by pushing the SET key here.	The keys are locked after the power is turned on and cannot be operated. <i>Loc</i> is indicated on LED when the keys are pushed.
Min. pressure setting	3	Press the SET key.	<i>F_1</i> is indicated on LED.
	4	Set the required min. pressure by using the UP and DOWN keys.	The min. pressure is equal to 0 VDC input signal.
	5	When finished, press the SET key.	<i>F_2</i> is indicated on LED.
Max. pressure setting	6	Set the required max. pressure by using the UP and DOWN keys.	The max. pressure is equal to 10 VDC input signal.
	7	When finished press the SET key.	<i>P_1</i> is indicated on LED.

Continues on next page

Mode		Action	Note
Setting switch output, P1	8	Set the value 0 (zero) by using the UP and DOWN keys.	There are three kinds of modes of the switch function: <ul style="list-style-type: none"> • Window Comparator Mode • Hysteresis Mode • Out of range Mode The choice of the different modes is determined by setting the two values P1 and P2 and the relation between value P1 and value P2. P1=P2=0 Out of range mode
	9	When finished, press the SET key.	P_2 is indicated on LED.
Setting switch output, P2	10	Set the value 0 (zero) by using the UP and DOWN keys.	
	11	When finished, press the SET key.	LED returns to the present pressure indication. Setting is completed.
Active key locking	12	The indication <i>unL</i> flashes on LED when the DOWN key is pressed for two seconds or more. Key locking function is released by pressing SET key here.	

Pre-set values

Parameter	Pre-set value
Min. pressure F1	0.0 MPa
Max. pressure F2	0.9 MPa
Switch output	Out of range mode (P1=P2=0)

Insufficient air pressure (Only applicable to type S)

If the Air pressure switch indicates too low pressure, the 24 V supply of the Electrical proportional valve is disconnected and the valve stops from operating.

If the Air pressure switch is to be set without having sufficient air pressure, the corresponding digital output *gx_epvalve_on* supplying the valve with 24 V, has to be set manually. This is most easily done by simulating input *gx_air_ok*.

2 Installation

2.7 Test run after installation, maintenance, or repair

2.7 Test run after installation, maintenance, or repair

Safe handling

Use the following procedure after installation, maintenance, or repair, before initiating motion.



DANGER

Initiating motion without fulfilling the following aspects, may increase the risk for injury or cause damage to the robot.

	Action
1	Remove all tools and foreign objects from the robot and its working area.
2	Verify that the robot is properly secured to its position by all screws, before it is powered up.
3	Verify that any safety equipment installed to secure the position or restrict the robot motion during service activity is removed.
4	Verify that the fixture and work piece are well secured, if applicable.
5	Verify that all safety equipment is installed, as designed for the application.
6	Verify that no personnel are inside the safeguarded space.
7	If maintenance or repair has been done, verify the function of the part that was maintained.
8	Verify the application in the operating mode manual reduced speed.

Collision risks



CAUTION

When programming the movements of the robot, always identify potential collision risks before initiating motion.

3 Maintenance

3.1 Introduction

Structure of this chapter

This chapter describes all the maintenance activities recommended for the DressPack IRB6650S.

It is based on the maintenance schedule found at the beginning of the chapter. The schedule contains information about required maintenance activities including intervals, and refers to procedures for the activities.

Each procedure contains all the information required to perform the activity, including required tools and materials.

The procedures are gathered in different sections and divided according to the maintenance activity.

Safety information

Observe all safety information before conducting any service work.

There are general safety aspects that must be read through, as well as more specific safety information that describes the danger and safety risks when performing the procedures. Read the chapter [Safety on page 17](#) before performing any service work.

The maintenance must be done by qualified personnel in accordance with the safety requirements set forth in the applicable national and regional standards and regulations.

3 Maintenance

3.2.1 Maintenance schedule

3.2 Maintenance schedule and component life

3.2.1 Maintenance schedule

General

The DressPack must be maintained regularly to ensure its function. The lifetime of a process cable package can be extended with the correct preventive maintenance activities. A daily visual check of the DressPack is highly recommended, which is normally performed by robot production personnel. It is essential that the person performing the visual check have basic training in ABB DressPack.

Wear parts

Wear parts should be replaced before considerable damage occurs to the process cable package. Replace wear parts before the part is completely damaged.

The following parts are considered as wear parts:

- Protection sleeves
- Protective hose
- Hose reinforcement
- Slide sleeves
- Damper

Activities and intervals, standard equipment

The sections referred to in the table can be found in the different chapters for each maintenance activity.

The table below specifies the required maintenance activities and intervals:

Maintenance activity	Equipment	Interval	Detailed in section:
Inspection	Water & Air unit	1 month	Preventive inspection of Water and air unit on page 219
Inspection	All cables	Regularly ⁱ	Preventive inspection of all cables, DressPack on page 210
Inspection	DressPack upper arm	Regularly <i>i</i>	Preventive inspection, DressPack upper arm on page 212
Cleaning	DressPack upper arm	Regularly <i>i</i>	Cleaning, DressPack upper arm on page 222
Cleaning	Water & Air unit	Regularly <i>i</i>	Cleaning, Water and air unit on page 225

ⁱ "Regularly" implies that the activity is to be performed regularly, but the actual interval may not be specified by the robot manufacturer. The interval depends on the operation cycle of the robot, its working environment and movement pattern.

Generally, the more contaminated the environment, the closer the maintenance intervals. Also, the more demanding the movement pattern (sharper bending cable harness), the closer the intervals.

Continues on next page

DressPack upper arm cable package

Based on experience, some parts are more exposed to wear. Therefore the DressPack upper arm cable package should be inspected according to the following schedule.

Interval	Action
Weekly	None
Every two weeks	Inspection wear
Every third month	Inspection
After changing movement pattern	Inspection

3 Maintenance

3.3.1 Preventive inspection of all cables, DressPack

3.3 Inspection activities

3.3.1 Preventive inspection of all cables, DressPack

Cables in the DressPack system

There are many different cables used in the DressPack system. The different cables used are listed in Spare parts section.

The inspection activities described below are a general description, and does not refer to any specific cable.

Required equipment

Equipment	Art. no.	Note
Standard toolkit	3HAC17290-7	The contents are defined in section Toolkits, DressPack on page 357 .

Inspection

The procedure below details how to inspect all cables included in the DressPack system.

This instruction applies to:

- DressPack upper arm and cables and hoses contained within
- DressPack lower arm and cables and hoses contained within
- DressPack lower/upper arm and cables and hose contained within
- DressPack floor and cables and hoses contained within.

	Action	Note
1	 DANGER Turn off all: <ul style="list-style-type: none">• electric power supply• hydraulic pressure supply• air pressure supply to the robot, before entering the safe-guarded space.	
2	Make sure that the unit is clean and not overly contaminated.	Clean if required as detailed in section Cleaning, DressPack upper arm on page 222 .
3	Make sure that all bolts are fastened.	Recommended tightening torques are specified in section Screw joints on page 353 .
4	Make sure that all connections are fastened.	Re-tighten if necessary.
5	Make sure that all hose connections are fastened and that there are no leaks.	Re-tighten if necessary.

Continues on next page

3.3.1 Preventive inspection of all cables, DressPack Continued

	Action	Note
6	Check for mechanical wear, especially in areas where the cable/hose package rub against, or move close to, the robot or any other structure. Especially check any cable/hose package at the robot wrist.	Replace any worn items as detailed in the chapter Repair on page 227 . Re-adjust the assembly after installation.
7	If any of the protective sleeves are worn, rotate it or replace it.	Detailed in section Replacement of protective sleeves on page 304 .
8	Check the attachments of the cable/hose package, to make sure they are properly secured.	Secure any loose items as detailed in the Installation on page 35 chapter.
9	Check all cable retainers, to make sure the cables/hoses are securely locked in the cable retainers.	Tighten any loose retainers as detailed in section Preventive inspection of all cables, DressPack on page 210 . Tighten any loose cable retainers as detailed in section Fitting the cable package IRBDP SW2 CE on page 92 .

3 Maintenance

3.3.2 Preventive inspection, DressPack upper arm

3.3.2 Preventive inspection, DressPack upper arm

Location of DressPack upper arm

The figure shows the cable package IRBDP SW2 UE.

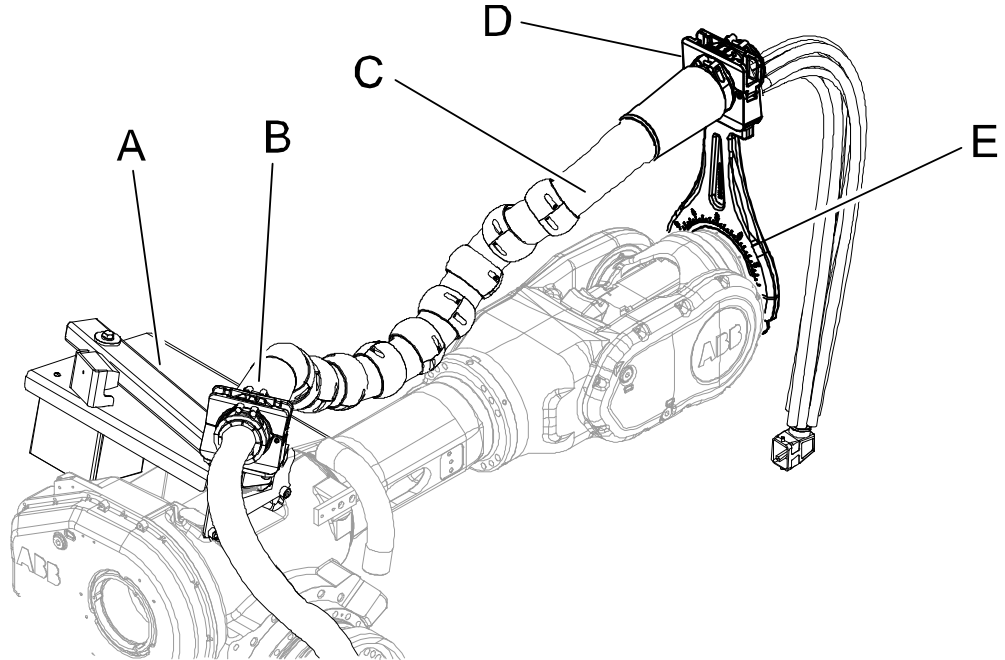

xx080000086

A	Tension arm unit
B	Ball joint housing (tension arm unit)
C	Process cable package, upper arm
D	Ball joint housing (process cable support axis 6)
E	Process cable support axis 6

Continues on next page

The figure shows the cable package IRBDP SW5 CE.

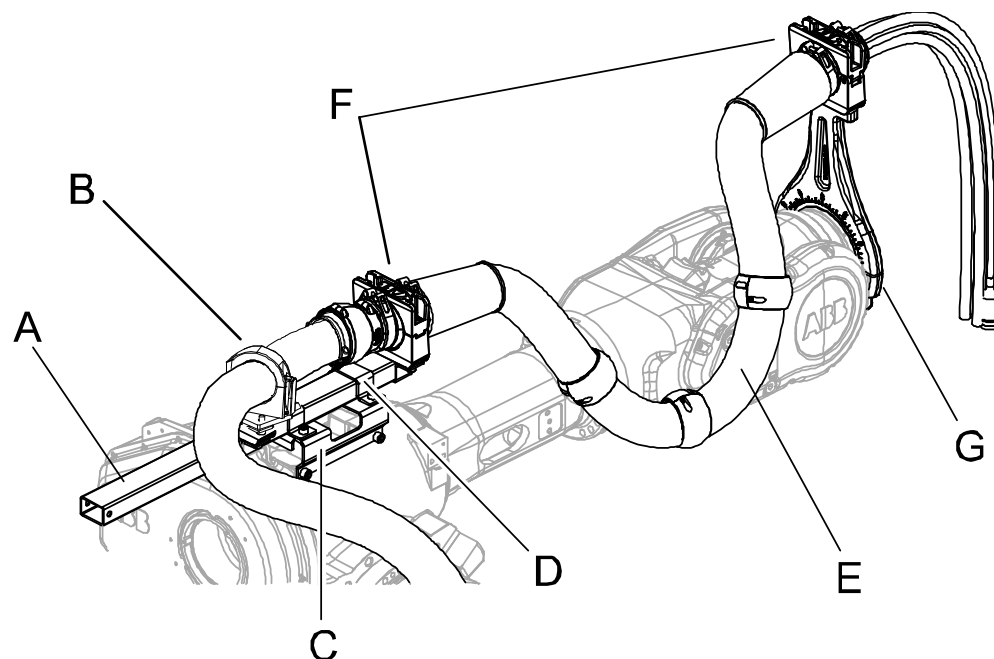

xx080000087

A	Adjustable bracket
B	Gripping clamp
C	Axis 3 bracket
D	Bracket
E	Process cable package IRBDP SW5 CE, upper end
F	Ball joint housing
G	Process cable support axis 6

Required equipment

Equipment	Article number	Note
Standard toolkit	3HAC17290-7	The contents are defined in section Toolkits, DressPack on page 357 .

Inspection - Robot standing still

Use this procedure to inspect the DressPack when the robot is not in motion.

	Action	Note
1	 DANGER Turn off all: <ul style="list-style-type: none"> • electric power supply • hydraulic pressure supply • air pressure supply to the robot, before entering the safe-guarded space.	

Continues on next page

3 Maintenance

3.3.2 Preventive inspection, DressPack upper arm

Continued

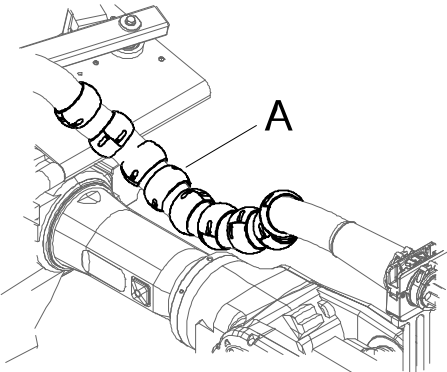
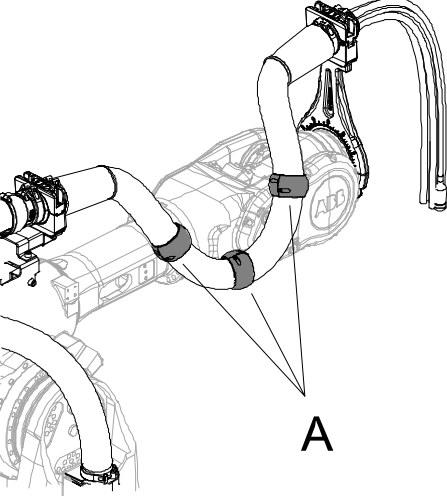
	Action	Note
2	Make sure that the DressPack is not contaminated.	If required, clean as detailed in section Cleaning, DressPack upper arm on page 222 .
3	Make sure that all bolts are fastened.	Recommended standard tightening torques are specified in section Screw joints on page 353 .
4	<p>(Not applicable to cable package IRBDP MH3 UE)</p> <p>Check the position and state of the <i>protective sleeves</i>.</p> <p>Place these where they prevent the protection hose from rubbing against the upper arm of the robot, as much as possible.</p> <p>If required, additional protective sleeves may be fitted.</p> <p> Note</p> <p>When fitting several protective sleeves, always leave a space between them (approximately the width of one slide sleeve).</p>	<p>IRBDP SW2 UE</p>  <p>xx0500001441</p> <p>IRBDP SW5 CE</p>  <p>xx0800000084</p> <p>Parts:</p> <ul style="list-style-type: none"> • A: Protective sleeves <p>Make a note of where the protective sleeves were positioned to facilitate replacing them in the future.</p> <p>If required, replace the protective sleeves.</p>

Continues on next page

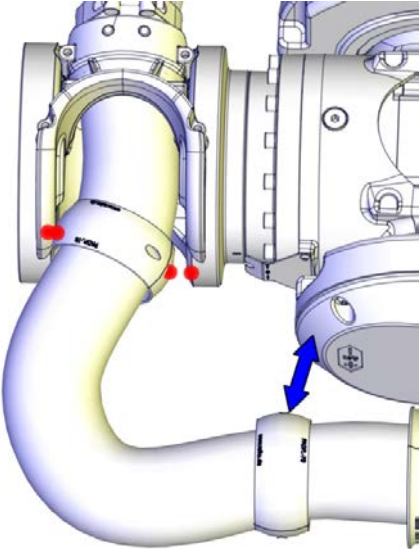
	Action	Note
5	<p>Only applicable to cable packages IRBDP SW6 UI & IRBDP MH6 UI:</p> <p>Check the position and state of the <i>protective sleeves</i>.</p> <p>Correct fitting of the protective sleeve at the wrist cover:</p> <ul style="list-style-type: none"> • align the center of the radius on the front end of the wrist cover, with the center of the radius on the corresponding protective sleeve. See figure! <p>Correct fitting of the protective sleeve at the axis-6 cable support:</p> <ul style="list-style-type: none"> • align the center of the radius (right side) of the axis-6 cable support, with the center of the radius of the corresponding protective sleeve. See figure! <p>Replace protective sleeves if needed. For correct fitting of the new protective sleeve, see instructions above for a correct fitting. The number of protective sleeves must remain the same (2 pcs).</p>	 <p>xx140000224</p>
6	<p>Make sure all cable straps are tight enough to prevent the cable package from moving in an undesired way.</p>	
7	<p>Make sure that the velcro strap are not too tight. The cables should be able to twist.</p>	
8	<p>Make sure that the cable package is properly connected at:</p> <ul style="list-style-type: none"> • the connection plate • the robot base • the lower arm • the tool on the turning disc of the robot. 	
9	<p>Make sure that all connections are fastened and that there are no leaks.</p>	<p>Re-tighten if necessary.</p>
10	<p>Make sure that the cable package is not cracked or damaged in any other way.</p>	

Continues on next page

3 Maintenance

3.3.2 Preventive inspection, DressPack upper arm

Continued

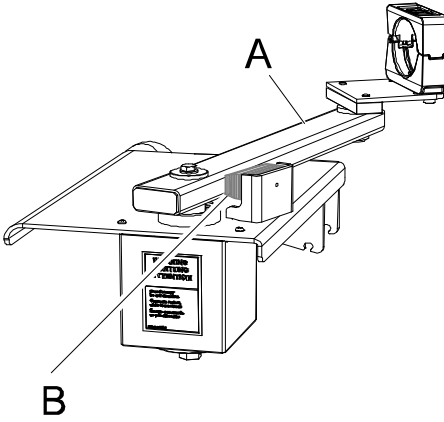
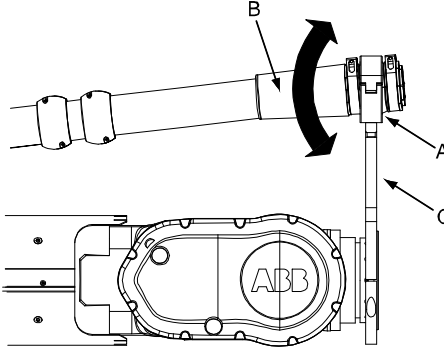
	Action	Note
11	<p>(Not applicable to cable package IRBDP SW5 CE, IRBDP MH6 UI and IRBDP SW6)</p> <p>Inspect the <i>rubber damper</i>.</p> <p>Make sure it is not chipped or damaged in any other way.</p>	 <p>xx0700000318</p> <p>Parts:</p> <ul style="list-style-type: none"> • A: Tension arm • B: Rubber damper <p>If required, replace the damper.</p>
12	<p>(Not applicable to cable package IRBDP MH3 UE, IRBDP MH6 UI and IRBDP SW6)</p> <p>Make sure the <i>sliding surfaces</i> at both ends of the slide sleeves (at the process cable support axis 6 as well as at the tension arm unit) has not been damaged or show excessive wear.</p> <p>Check this with normal hand force:</p> <ol style="list-style-type: none"> 1 grab hold of the package 2 pull and turn to make sure that the package is free to slide. <p>If the slide sleeves are too worn:</p> <ol style="list-style-type: none"> 1 disassemble and clean 2 replace. <p>Always make sure that the slide sleeves are clean! If they are dirty, clean them!</p>	 <p>xx0300000199</p> <p>Parts:</p> <ul style="list-style-type: none"> • A: Slide sleeve slide surface • B: Hose reinforcement • C: Process cable support axis 6 <p>A damaged surface may potentially prevent the cable package from rotating, thus causing excessive wear.</p> <p>Cleaning agent is specified in section Required equipment on page 213.</p> <p>If required, replace the slide sleeves as detailed in section Replacement of slide sleeves on page 330.</p>

Continues on next page

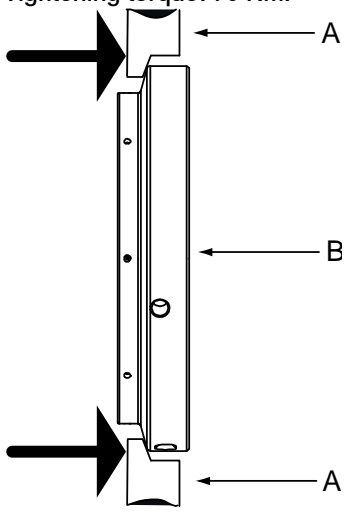
	Action	Note
13	<p>(Not applicable to cable package IRBDP MH3 UE)</p> <p>Check that the process cable support axis 6 is fully pushed forward against the turning disc axis 6.</p>	<p>If needed, adjust tightening torque. Tightening torque: 70 Nm.</p>  <p>xx0400001040</p> <p>Parts:</p> <ul style="list-style-type: none"> • A: Process cable support axis 6 • B: Turning disc axis 6
14	<p>(Not applicable to cable package IRBDP MH3 UE, IRBDP MH6 UI and IRBDP SW6)</p> <p>Visually inspect the <i>hose reinforcement</i> to make sure there are no cracks or other damage.</p>	<p>Shown in the figure above. If required, replace the hose reinforcement as detailed in the section Replacement of hose reinforcement on page 327.</p>
15	<p>Check all cable clamps securing the process cable package and protective hose for tightness.</p>	<p>Tightening torques are specified either in:</p> <ul style="list-style-type: none"> • Installation chapter (non-standard tightening torques) or • standard tightening torque table (standard tightening torques).

Inspection - Reduced speed

The following procedure details how to inspect the DressPack upper arm when the robot is moving in reduced speed.



WARNING

A robot in motion is dangerous and may cause severe personal injuries, if safety procedures are not followed. Hence, all work must be performed outside the robots working range and outside the robots safety area.

Secure the following before work starts:

- Check that all emergency stops are fully functional.
- Close and activate all safety equipment (safety gates and/or safety curtains etc.).

	Action
1	<p>Make sure that no hoses or cables, or parts thereof, touch any part of the robot structure in a way that may cause wear.</p>

Continues on next page

3 Maintenance

3.3.2 Preventive inspection, DressPack upper arm

Continued

	Action
2	Make sure all cables and hoses move smoothly together during operation and that no part of the cable package moves in a different pattern.

Inspection - Full speed

The following procedure details how to inspect the DressPack upper arm, when the robot is moving in full speed.



WARNING

A robot in motion is dangerous and may cause severe personal injuries, if safety procedures are not followed. Hence, all work must be performed outside the robots working range and outside the robots safety area.

Secure the following before work starts:

- Check that all emergency stops are fully functional.
- Close and activate all safety equipment (safety gates and/or safety curtains etc.).

	Action	Note
1	Make sure that no hoses or cables, or parts thereof, touch any part of the robot structure (or something in the vicinity of it) in a way that may cause wear.	
2	Make sure all cables and hoses move smoothly together during operation and that no part of the cable package moves in a different pattern.	
3	(Not applicable to cable package IRBDP MH3 UE, IRBDP SW6 UI and IRBDP MH6 UI) Make sure that when the robot program is running, the movement of the tension arm unit shall be smooth, but still strong enough to retract the hose package without excessive force.	

3.3.3 Preventive inspection of Water and air unit

Location of Water and air unit, type S

The Water and air unit is located as shown in the figure.

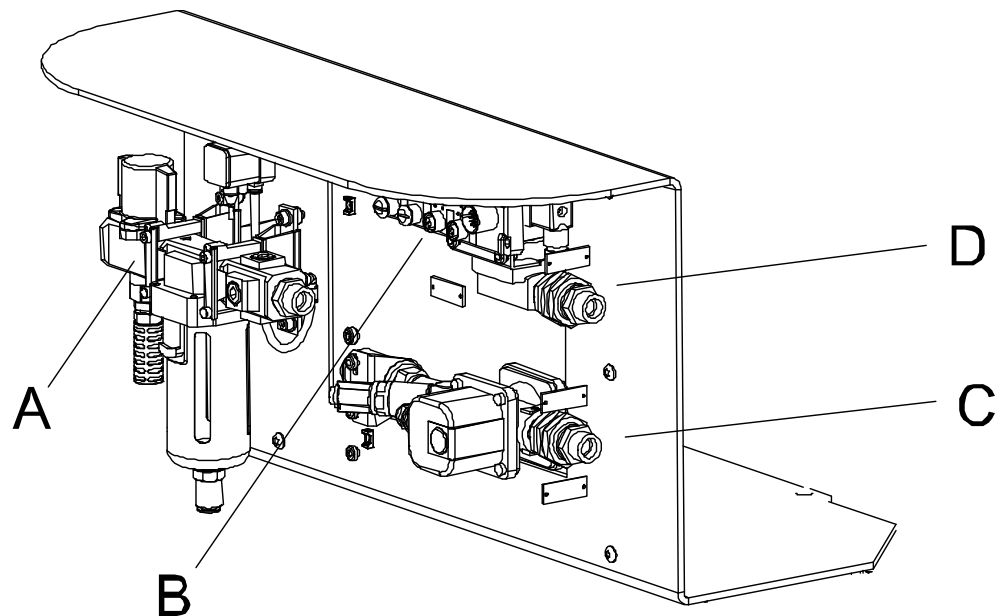

xx0600003293

A	Air supply circuit
B	Split box
C	Water return circuit
D	Water in circuit

Location of Water and air unit, type Sb

The Water and air unit is located as shown in the figure.

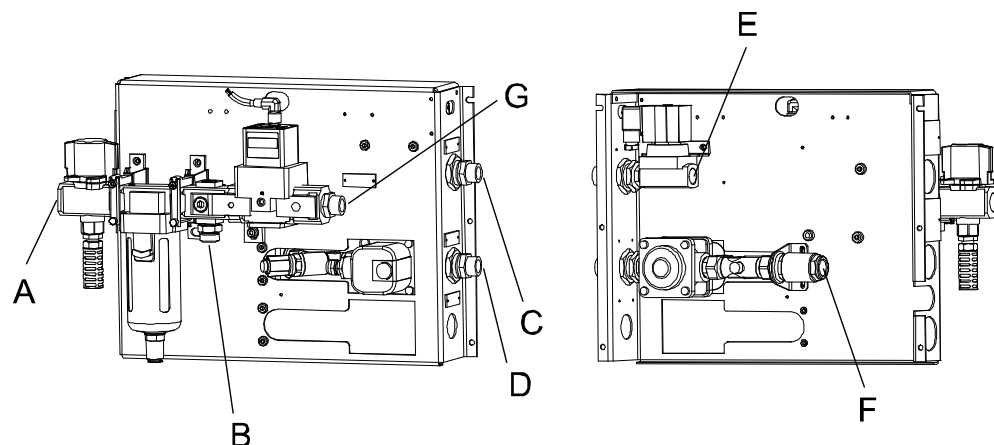

xx0800000122

A	Shop compressed air supply
B	PROC 1 on robot base

Continues on next page

3 Maintenance

3.3.3 Preventive inspection of Water and air unit

Continued

C	PROC 2 on robot base
D	PROC 3 on robot base
E	Shop water supply
F	Shop water drain
G	PROC 4 on robot base (option)

Required equipment

Equipment	Article number	Note
Standard Toolkit, DressPack	3HAC17290-7	The contents are defined in section Toolkits, DressPack on page 357 .

General inspection

The procedure below describes how to perform a general inspection of the Water and air unit.

	Action	Note
1	Check that the Water and air unit is not contaminated.	Clean if required as detailed in section Cleaning, Water and air unit on page 225 .
2	Check that the bolts are fastened.	Recommended tightening torques are specified in section Tightening torque on page 354 .
3	<p>Check that all connections are correctly made and that there are no leaks.</p> <p> CAUTION</p> <p>Do not tighten the brass couplings for water and air with excessive force.</p>	<p>Retighten if necessary.</p> <p>Tightening torque:</p> <ul style="list-style-type: none"> • Brass coupling 1/2": 31 Nm. • Stainless steel coupling 1/2": 49 Nm. • Brass coupling 3/8": 17 Nm. • Mixed metals: Use the lower tightening torque value of the two metals. <p>Always apply Molykote P1900 to stainless steel couplings and apply if needed for couplings of mixed metals or brass.</p>

Inspection, air supply circuit

The procedure below describes how to inspect the air supply circuit.

	Action	Note
1	<p>Check if there is water in the filter receptacle.</p> <p>Normally the filter receptacle is drained automatically in case of a fall of air pressure. If there is no fall of pressure in the air system, there is an automatic draining of the system, when the water level reaches a certain level.</p>	<p>If there is a lot of water in the filter receptacle, this is a sign that the supplied air consist of too much water.</p> <p>If this is the case, steps must be taken to correct this problem!</p>
2	Drain the air filter receptacle manually by pressing a small pin at the bottom of the air filter unit.	
3	Make a check that there is no leakage.	Retighten if necessary!

Continues on next page

	Action	Note
4	Make a check of the condition of the air filter.	If needed replace the air filter. Normally the filter should be replaced after one year of use.

Inspection, water in and water return circuits

The procedure below describes how to inspect the water in and water return circuits.

	Action	Note
1	Open the hand operated ball valve for water inlet.	
2	Open the water return valve on the water in circuit.	
3	Close the hand operated ball valve for water outlet.	
4	While the system is under pressure, check if there are any leaks.	Retighten if necessary!
5	Reset the system.	

3 Maintenance

3.4.1 Cleaning, DressPack upper arm

3.4 Cleaning activities

3.4.1 Cleaning, DressPack upper arm

Location DressPack upper arm

The figure shows cable package IRBDP SW2 UE.

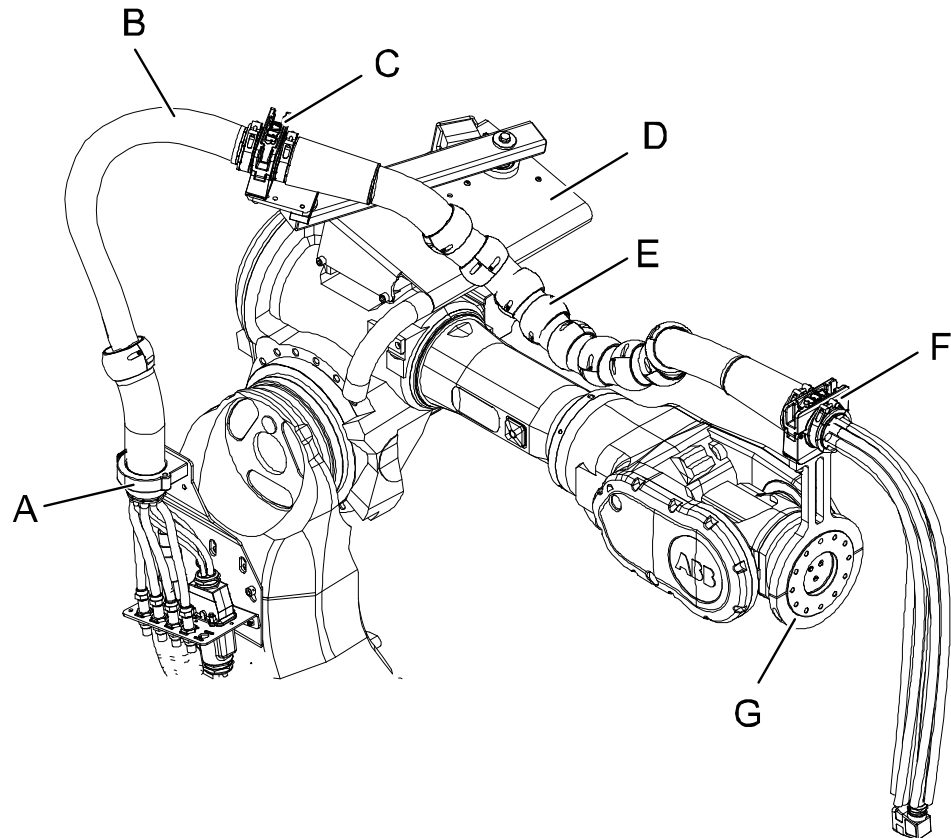

xx0500001530

A	Gripping clamp (lower arm)
B	Cable package, upper arm
C	Ball joint housing (tension arm unit)
D	Tension arm unit
E	Protective sleeves
F	Ball joint housing (process cable support axis 6)
G	Process cable support axis 6, complete

Continues on next page

The figure shows cable package IRBDP SW5 CE.

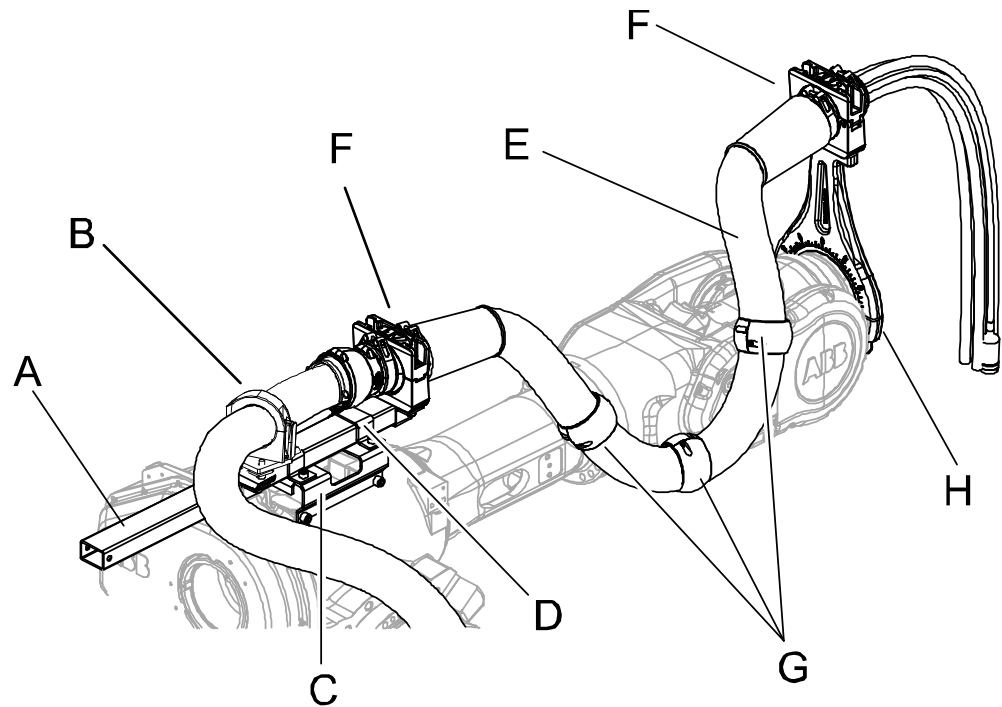

xx080000088

A	Adjustable bracket
B	Gripping clamp
C	Axis 3 bracket
D	Bracket
E	Process cable package IRBDP SW5 CE, upper end
F	Ball joint housing
G	Slide sleeves
H	Process cable support axis 6

Required equipment

Equipment	Art. no.	Note
Standard toolkit	3HAC17290-7	The contents are defined in section Toolkits, DressPack on page 357 .
Dry rag and medium soft brush		For cleaning the protective hose ribs.

Continues on next page

3 Maintenance

3.4.1 Cleaning, DressPack upper arm

Continued

Cleaning

The procedure below details how to clean the DressPack upper arm.

	Action	Note
1	Clean the DressPack upper arm exterior, in order to avoid filling up the spaces between the ribs with debris. Make sure to clean any areas where any hoses bend or rub against the robot. If the harness is not cleaned sufficiently, breakage of the protective hose may result.	Only use equipment and cleaning agents as specified in section Required equipment on page 210 .
2	Clean the slide sleeves of any sort of contamination.	

3.4.2 Cleaning, Water and air unit

Location of Water and air unit, type S

The Water and air unit is located as shown in the figure.

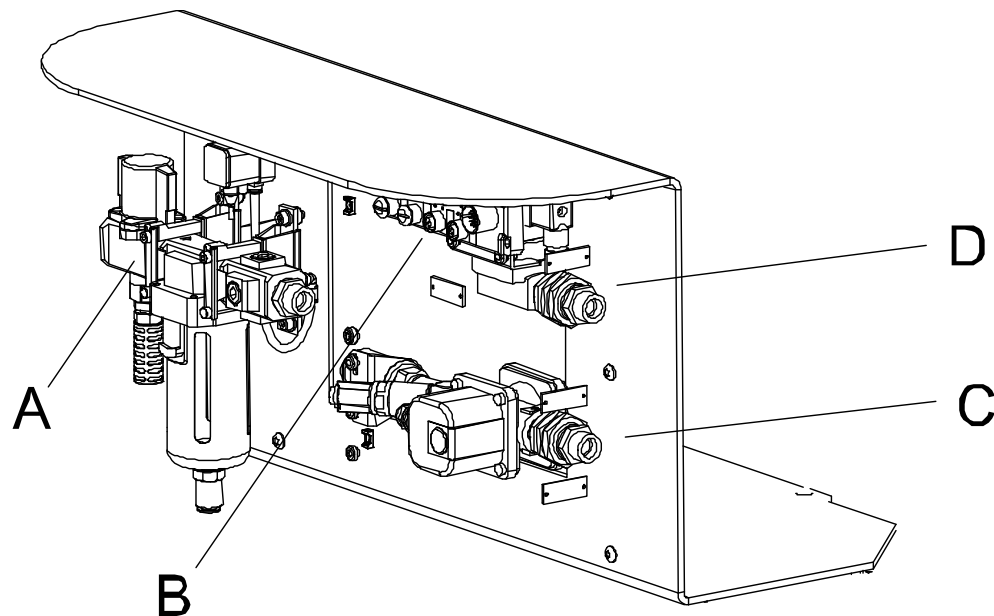

xx0600003293

A	Air supply circuit
B	Split box
C	Water return circuit
D	Water in circuit

Location Water and air unit, type Sb

The Water and air unit is located as shown in the figure.

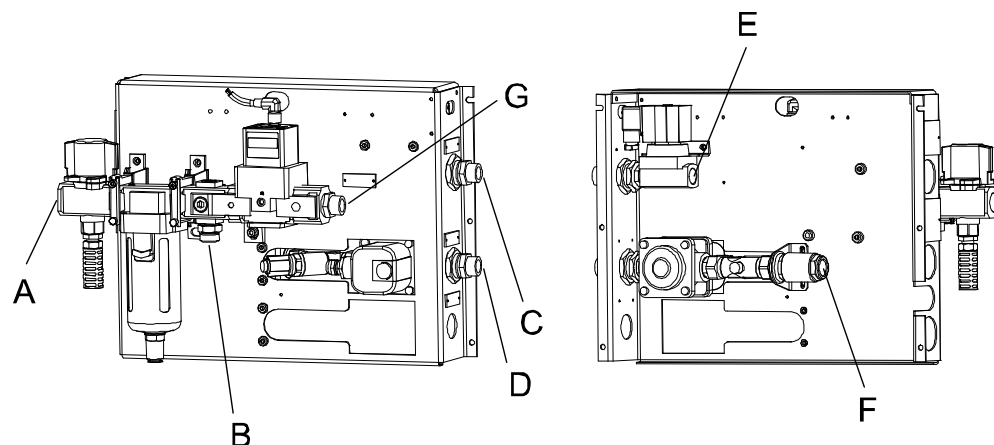

xx0800000122

A	Shop compressed air supply
B	PROC 1 on robot base

Continues on next page

3 Maintenance

3.4.2 Cleaning, Water and air unit

Continued

C	PROC 2 on robot base
D	PROC 3 on robot base
E	Shop water supply
F	Shop water drain
G	PROC 4 on robot base (option)

Required equipment

Equipment	Note
Dry rag	When cleaning the Water and air unit, only use household neutral detergent.

Maintenance of Air filter

	Action	Note
1	Periodically inspect the resin bowl for cracks or other deterioration.	If found, replace the bowl with a new one.
2	Periodically inspect the cleanliness of the resin bowl.	If the resin bowl is dirty, replace it with a new one or clean it. Use a household (neutral) detergent when cleaning, other detergent may break the bowl.
3	Replace the filter element within two years since first use.	Replacement of the air filter is detailed in section Replacement of Air filter element on page 346 .
4	Replace the filter after pressure drop from initial outlet reaches 0.1 MPa.	Replacement of the air filter is detailed in section Replacement of Air filter element on page 346 .
5	Replace if the filter element is broken.	Replacement of the air filter is detailed in section Replacement of Air filter element on page 346 .

4 Repair

4.1 Introduction

Structure of this chapter

This chapter describes repair activities for the DressPack IRB6650S. Each procedure contains the information required to perform the activity, for example spare parts numbers, required special tools, and materials.

**WARNING**

Repair activities not described in this chapter must only be carried out by ABB.

Report replaced units

**Note**

When replacing a part on the DressPack IRB6650S, report to your local ABB the serial number, the article number, and the revision of both the replaced unit and the replacement unit.

This is particularly important for safety equipment to maintain the safety integrity of the installation.

Safety information

Make sure to read through the chapter [Safety on page 17](#) before commencing any service work.

4 Repair

4.2.1 Repair activities

4.2 DressPack cable package

4.2.1 Repair activities

General

This section describes the main activities of replacing the cable packages or parts thereof.



CAUTION

The cabling is sensitive to mechanical damage. Handle it with care to avoid damage to the cabling or the connector, avoid any kind of tilt or skew.

Procedures

For information about:	Also see
Replacing the cable packages IRBDP MH2 LE and IRBDP SW2 LE.	Described in section Replacing the cable packages IRBDP MH2 LE and SW2 LE on page 238
Replacing the cable packages IRBDP MH2 UE and IRBDP SW2 UE.	Described in section Replacing the cable packages IRBDP MH2 UE and IRBDP SW2 UE on page 244
Replacement of the cable package IRBDP SW2 CE.	Described in section Replacement of cable package IRBDP SW2 CE on page 247
Replacing the cable package IRBDP MH1 LI and MH2 LI.	Described in section Replacing the cable packages - IRBDP MH1 LI and MH2 LI on page 230
Replacing the cable package IRBDP MH3 UE.	Described in section Replacing the cable package IRBDP MH3 UE on page 253
Replacing the cable package IRBDP SW5 CE (DressPack Basic).	Described in section Replacing the cable package IRBDP SW5 CE (DressPack Basic) on page 257 .
Replacement of <i>tension arm unit</i>	Described in section Replacement of tension arm unit on page 299
Replacement of <i>hose reinforcement</i>	Described in section Replacement of hose reinforcement on page 327 .
Replacement of <i>slide sleeves</i>	Described in section Replacement of slide sleeves on page 330 .
Repair of <i>process cable package</i>	Described in section Repair of process cable package on page 316
Adjusting <i>tension arm unit</i>	Described in section Adjusting tension arm unit on page 322

4.2.2 Addition of functional ground (Paramulti)

Configuration of customer connection plates

Only for Paramulti DressPack and for spare part replacement.

The Paramulti DressPack spare part includes functional ground. If the installed DressPack has not included functional ground previously, following action needs to be done:

Drill an 8.4 mm mm hole in the customer plate according to the figure.

Customer connection plate at the upper arm housing

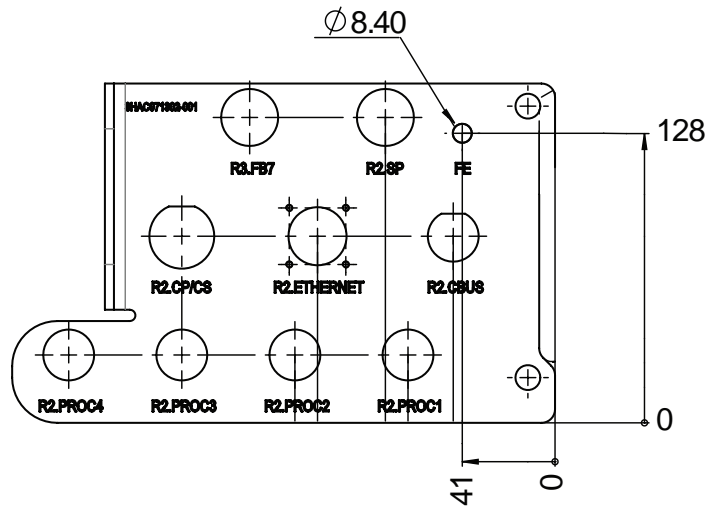

xx1900001269

Customer connection plate at the base

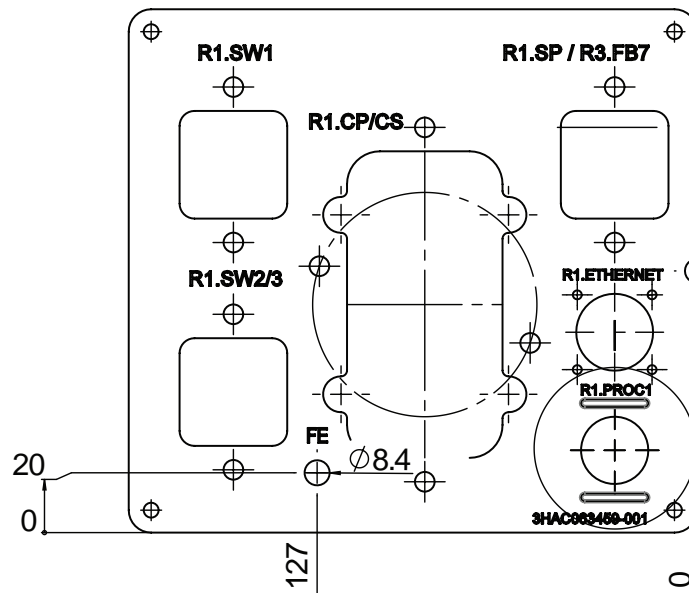

xx1900001268

4 Repair

4.2.3 Replacing the cable packages - IRBDP MH1 LI and MH2 LI

4.2.3 Replacing the cable packages - IRBDP MH1 LI and MH2 LI

Introduction

This procedure describes (in two steps) how to replace the internal process cable packages:

- IRBDP MH1 LI *and*
- IRBDP MH2 LI.

Location of the cable package IRBDP MH1 LI

The cable package IRBDP MH1 LI is located as shown in the illustration.

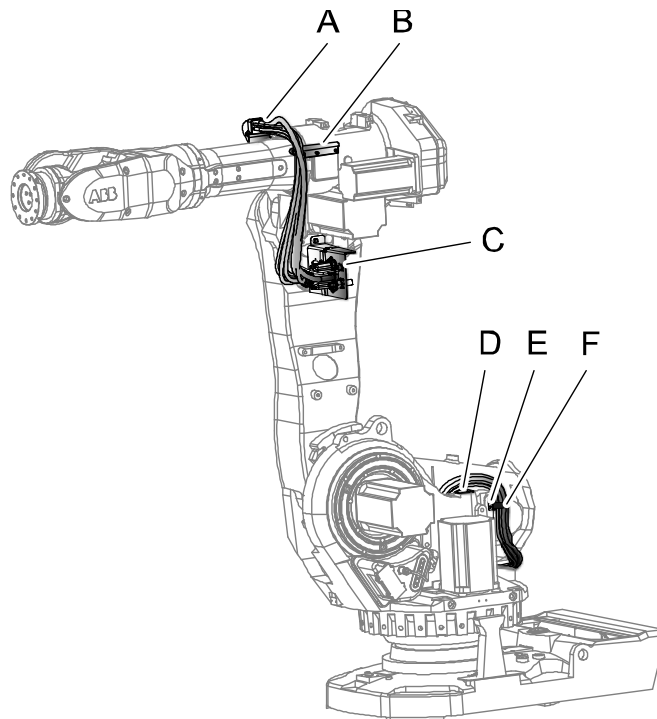

xx100000123

A	Cable bracket
B	Cable guide and strap
C	Connection plate
D	Bracket
E	Cable fixing bracket
F	Strap

Continues on next page

Location of the cable package IRBDP MH2 LI

The cable package IRBDP MH2 LI is located as shown in the illustration.

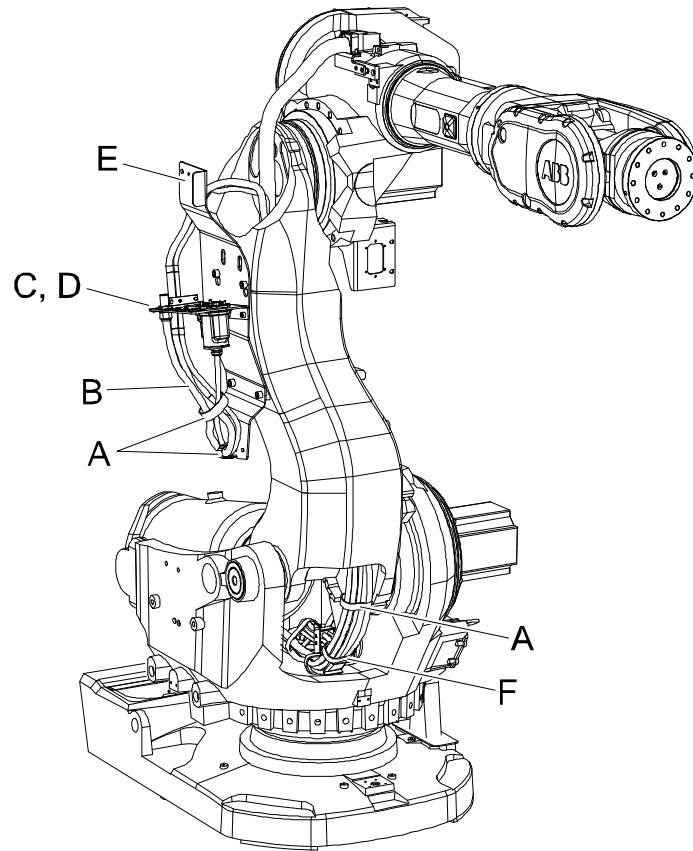

xx0500001534

A	Velcro straps
B	Lower arm internal cable package
C	Cable fixing bracket
D	Connection plate
E	Lower arm plate
F	Cable bracket, base frame

Required equipment

The following equipment is required for replacement of the cable packages IRBDP MH1 LI and MH2 LI.

Equipment	Note
Cable packages IRBDP MH1 LI and MH2 LI	See <i>Spare Parts!</i> A number of version are available, see Lower arm Internal cable package on page 363
Standard toolkit, DressPack	The content is described in section <i>Toolkit, DressPack</i>

Continues on next page

4 Repair



4.2.3 Replacing the cable packages - IRBDP MH1 LI and MH2 LI

Continued

Equipment	Note
Other tools and procedures may be required. See references to these procedures in the step-by-step instructions below.	These procedures include references to the tools required.
Locking liquid (Loctite 243)	For locking attachment screws specified in the procedure.
Circuit diagram	Art. no. 3HAC026209-001

Replacing the cable packages IRBDP MH1 LI and MH2 LI - the first part

Use this procedure to replace the cable packages IRBDP MH1 LI and MH2 LI, the first part.

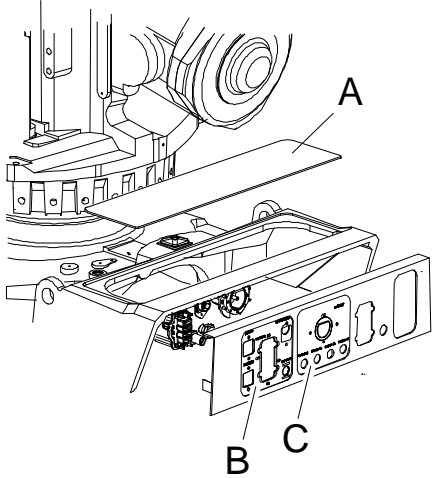
	Action	Note
1	 DANGER Turn off all: <ul style="list-style-type: none"> • electric power supply • hydraulic pressure supply • air pressure supply to the robot, before entering the robot working area.	
2	 CAUTION The cable package is sensitive to mechanical damage. They must be handled with care, especially the connectors, in order to avoid damaging them.	
3	Remove the <i>cover plate</i> .	
4	Disconnect <i>hose and connectors</i> from the <i>customer plate</i> .	 <p>xx0500001422</p> <p>Parts:</p> <ul style="list-style-type: none"> • A: Cover plate • B: Customer plate • C: Process plate (Not included in MH)

Continues on next page

4.2.3 Replacing the cable packages - IRBDP MH1 LI and MH2 LI

Continued

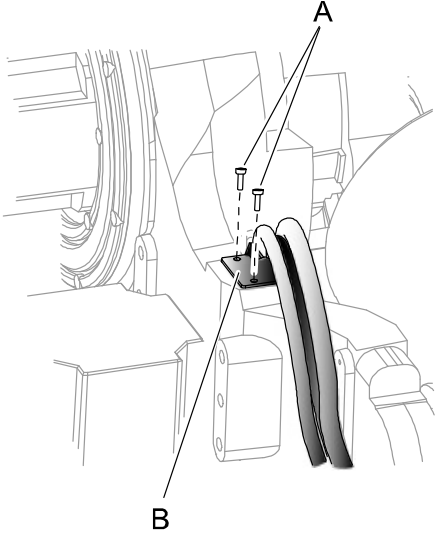
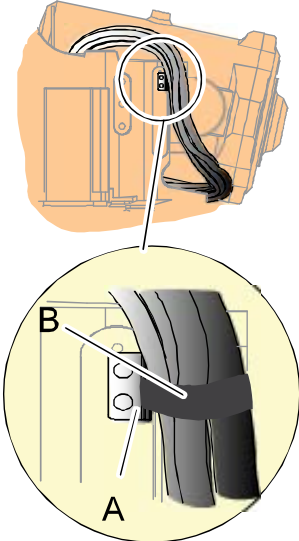
	Action	Note
5	Loosen the <i>cable and hose clamp</i> attached to the base frame.	 <p>xx0500001538</p> <p>Parts:</p> <ul style="list-style-type: none"> • A: Attachment screws (2 pcs) • B: Cable and hose clamp
6	Cut the <i>cable strap</i> securing the cable harness to the cable fixing bracket.	 <p>xx1000000118</p> <p>Parts:</p> <ul style="list-style-type: none"> • A: Cable fixing bracket • B: Cable strap
7	Pull the lower end of the cable package up through the hole of axis 1.	

Continues on next page

4 Repair

4.2.3 Replacing the cable packages - IRBDP MH1 LI and MH2 LI

Continued

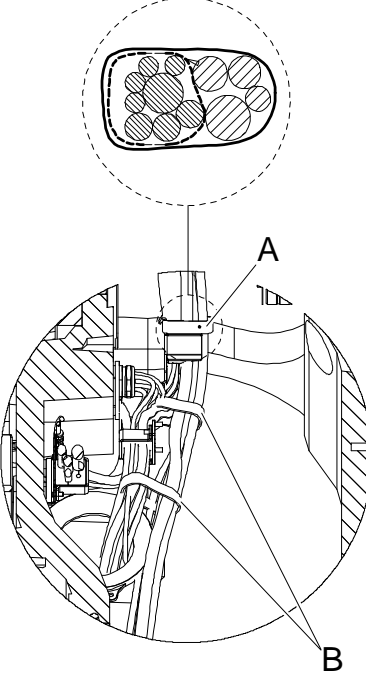
	Action	Note
8	Remove the cable package from the cable bracket on the inside of the base frame.	 <p>xx0500001546</p> <p>Parts:</p> <ul style="list-style-type: none"> • A: Existing + new velcro strap • B: New velcro strap (2 pcs)
9	Only applicable to IRB 6650! Remove the <i>cable bracket</i> from the rail inside the lower arm.	
10	Continue with step two of replacing the process cable package, depending on variant.	Depending on which cable harness is used, continue with step two at: <ul style="list-style-type: none"> • IRBDP MH1 LI : Replacing the cable package IRBDP MH1 LI - the second part on page 234 • IRBDP MH2 LI : Replacing the cable package IRBDP MH2 LI - the second part on page 235

Replacing the cable package IRBDP MH1 LI - the second part

Use this procedure to continue with the second part of replacing the cable package IRBDP MH1 LI.

	Action	Note
1	Disconnect all <i>hose and cable connectors</i> from the <i>connection plate</i> .	
2	Remove the <i>cable bracket</i> securing the cable package on the upper arm.	

Continues on next page

4.2.3 Replacing the cable packages - IRBDP MH1 LI and MH2 LI

Continued

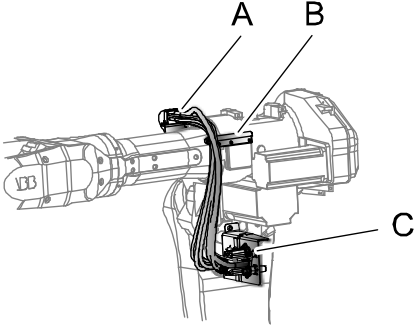
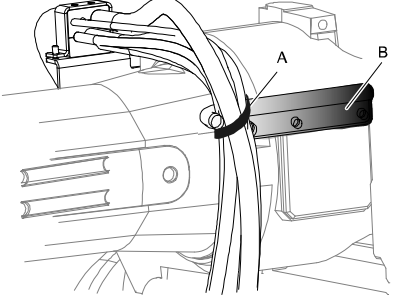
	Action	Note
3	Cut the <i>cable strap</i> on the cable guide.	 <p>xx100000127</p> <p>Parts:</p> <ul style="list-style-type: none"> • A: Cable bracket • B: Cable guide and strap • C: Connection plate
4	Pull the cable package down through the lower arm and remove it.	 <p>xx100000128</p> <p>Parts:</p> <ul style="list-style-type: none"> • A: Strap • B: Cable guide
5	Replace the damaged cable package.	See section <ul style="list-style-type: none"> • Location of the cable package IRBDP MH1 LI on page 230

Replacing the cable package IRBDP MH2 LI - the second part

Use this procedure to continue with the second part of replacing the cable package IRBDP MH2 LI.

	Action	Note
1	Disconnect all <i>hose and cable connectors</i> from the <i>connection plate</i> .	

Continues on next page

4 Repair

4.2.3 Replacing the cable packages - IRBDP MH1 LI and MH2 LI

Continued

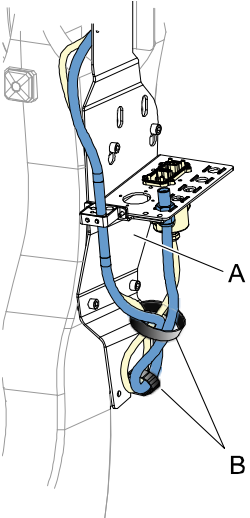
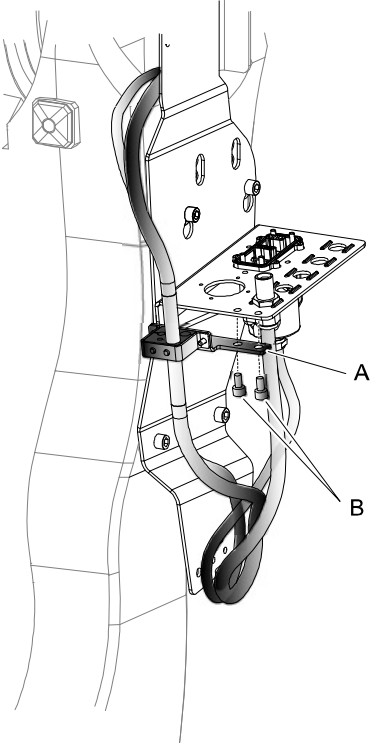
	Action	Note
2	Unstrap the <i>velcro straps</i> .	 <p>xx0500001545</p> <p>Parts:</p> <ul style="list-style-type: none">• A: Lower arm plate• B: Velcro strap (2 pcs)
3	Loosen the <i>cable fixing bracket</i> from the <i>connection plate</i> , and remove the cables and hoses from the connection plate.	 <p>xx0500001544</p> <p>Parts:</p> <ul style="list-style-type: none">• A: Cable fixing bracket• B: Attachment screw (2 pcs)
4	Pull the cable package down through the lower arm and remove it.	

Continues on next page

4.2.3 Replacing the cable packages - IRBDP MH1 LI and MH2 LI

Continued

	Action	Note
5	Replace the damaged cable package.	See section <ul style="list-style-type: none">• Location of the cable package IRBDP MH2 LI on page 231

4 Repair

4.2.4 Replacing the cable packages IRBDP MH2 LE and SW2 LE

4.2.4 Replacing the cable packages IRBDP MH2 LE and SW2 LE

Location of the cable package

The procedure below details how to replace the cable packages IRBDP MH2 LE and IRBDP SW2 LE. The actual work may differ due to the number of cables and hoses, type of connectors etc. However if differences are noticeable, these are pointed out in the procedure description.

The cable packages IRBDP MH2 LE and IRBDP SW2 LE consists of the parts shown in the illustration.

Continues on next page

4.2.4 Replacing the cable packages IRBDP MH2 LE and SW2 LE

Continued

Replacement of the upper arm cable package is detailed in section [Replacing the cable packages IRBDP MH2 UE and IRBDP SW2 UE on page 244](#).

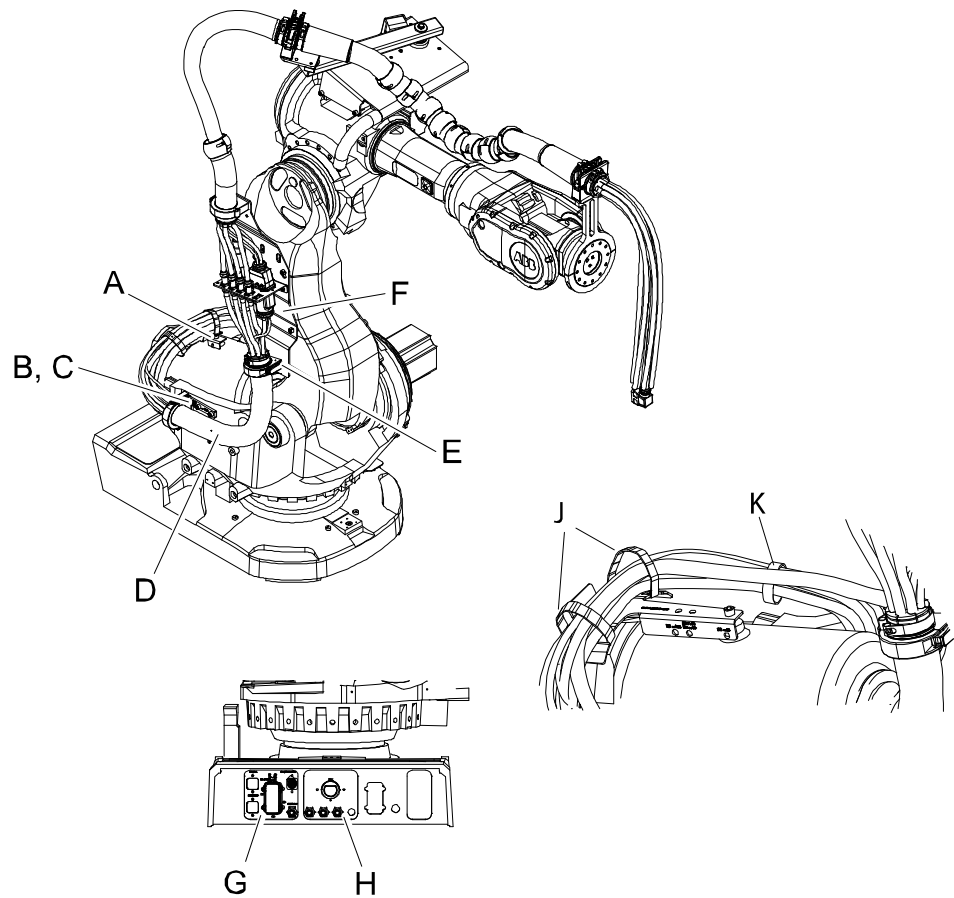

en0500001413

A	Attachment (balancing device)
B	Turn plate
C	Gripping clamp
D	Process cable package (lower arm)
E	Gripping clamp
F	Lower arm plate
G	Customer plate
H	Process plate
J	Straps
K	Velcro strap

Continues on next page

4 Repair

4.2.4 Replacing the cable packages IRBDP MH2 LE and SW2 LE

Continued



Required equipment

The following equipment is required for replacement of the cable packages.

Equipment	Art. no.	Note
Cable package IRBDP MH2 LE	For spare part number see chapter: <ul style="list-style-type: none">• Spare parts on page 361.	A number of version are available.
Cable package IRBDP SW2 LE	For spare part number see chapter: <ul style="list-style-type: none">• Spare parts on page 361.	A number of version are available.
Locking liquid	3HAB7116-1	For locking the cable clamps
Standard toolkit, DressPack	3HAC17290-7	The contents are defined in section Toolkits, DressPack on page 357 .
Other tools and procedures may be required. See references to these procedures in the step-by-step instructions below.		These procedures include references to the tools required.
Circuit diagram	3HAC026209-001	

Procedures

Use this procedure to remove the cable packages IRBDP MH2 LE and IRBDP SW2 LE from the robot, before it is disassembled.

	Action	Note
1	 DANGER Turn off all: <ul style="list-style-type: none">• electric power supply• hydraulic pressure supply• air pressure supply to the robot, before entering the robot working area.	
2	 CAUTION The cable package is sensitive to mechanical damage. They must be handled with care, especially the connectors, in order to avoid damaging them.	

Continues on next page

4.2.4 Replacing the cable packages IRBDP MH2 LE and SW2 LE

Continued

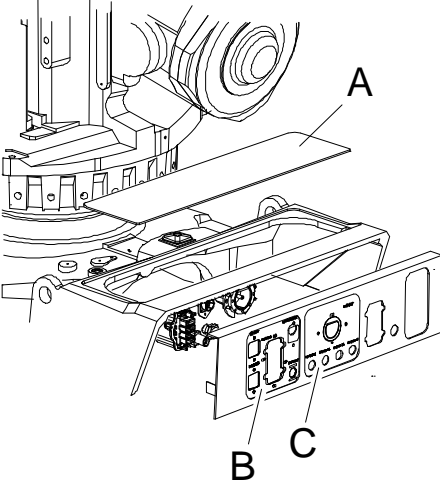
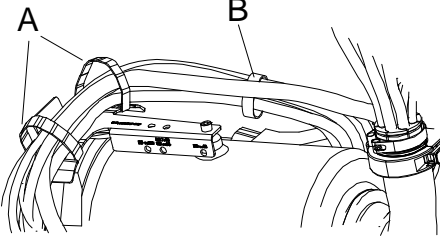
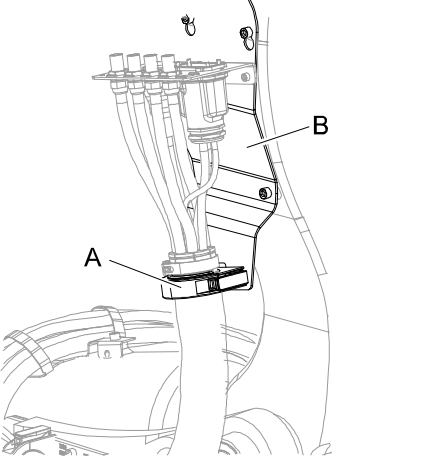
	Action	Note
3	Remove the <i>cover plate</i> .	 <p>xx0500001422</p> <p>Parts:</p> <ul style="list-style-type: none"> • A: Cover plate • B: Customer plate • C: Process plate
4	Open the <i>straps</i> and <i>velcro strap</i> .	 <p>xx0500001792</p> <p>Parts:</p> <ul style="list-style-type: none"> • A: Straps • B: Velcro strap
5	Disassemble the cable package from the <i>lower arm plate</i> .	 <p>xx0500001426</p> <p>Parts:</p> <ul style="list-style-type: none"> • A: Gripping clamp • B: Lower arm plate

Continues on next page

4 Repair

4.2.4 Replacing the cable packages IRBDP MH2 LE and SW2 LE

Continued

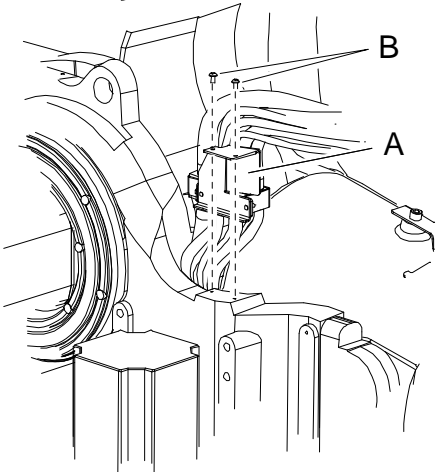
	Action	Note
6	<p>Disconnect all hoses from the <i>customer</i> and <i>process plates</i>.</p> <p> Note</p> <p>It is very important to disconnect the hoses to drain them from water before the disconnection of the cable connectors. This will minimize the risk of getting water into the electrical connectors.</p>	
7	<p>Disconnect the cable connectors from the customer and process plates.</p>	
8	<p>Loosen the weld cable clamp and pull the weld cable through the center hole of gear-box axis 1.</p>	
9	<p>Loosen the cable and hose clamp.</p>	 <p>xx0500001421</p> <p>Parts:</p> <ul style="list-style-type: none"> • A: Cable and hose clamp • B: Attachment screw (2 pcs)
10	<p>Pull the lower end of cable package out through the hole in gear box axis 1.</p> <p>Order of disassembly:</p> <ol style="list-style-type: none"> 1 Hoses 2 Signal cables 	

Continues on next page

4.2.4 Replacing the cable packages IRBDP MH2 LE and SW2 LE

Continued

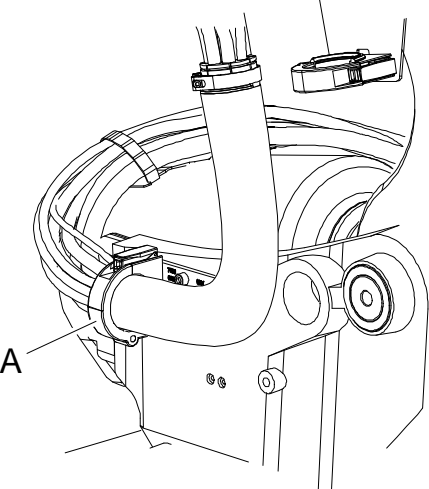
	Action	Note
11	Open the <i>gripping clamp</i> on the frame, and remove the cable package.	 <p>xx0500001425</p> <p>Parts:</p> <ul style="list-style-type: none"> • A: Gripping clamp on base frame.
12	Refit the new or repaired lower arm cable package.	Detailed in section, Fitting the cable packages IRBDP MH2 LE and IRBDP SW2 LE on page 74

4 Repair

4.2.5 Replacing the cable packages IRBDP MH2 UE and IRBDP SW2 UE

4.2.5 Replacing the cable packages IRBDP MH2 UE and IRBDP SW2 UE

Location of the cable packages IRBDP MH2 UE and IRBDP SW2 UE

This procedure describes how to replace the cable packages. The actual work may differ due to the number of cables and hoses, type of connectors etc. However, if differences are noticeable, these are pointed out in the procedure description.

The cable packages IRBDP MH2 UE and IRBDP SW2 UE consists of the parts shown in the figure.

Replacement of the lower arm cable package is described in section [Replacing the cable packages IRBDP MH2 LE and SW2 LE on page 238](#).

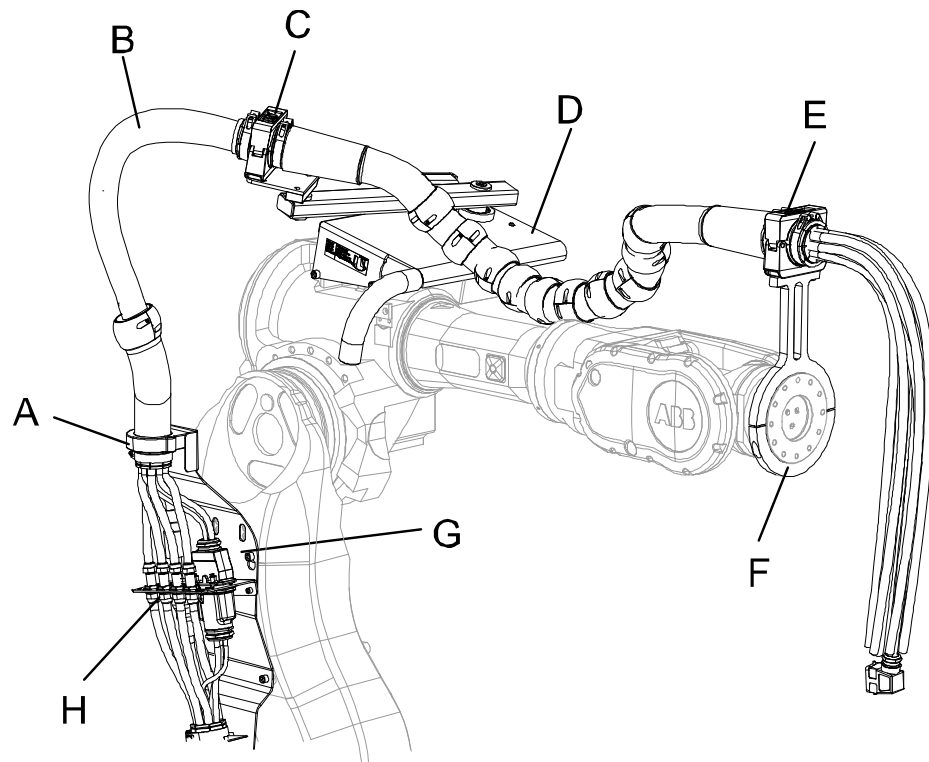

xx0500001490

A	Gripping clamp
B	Process cable package, upper arm
C	Ball joint housing (tension arm unit)
D	Tension arm unit
E	Ball joint housing (process cable support axis 6)
F	Process cable support axis 6, complete
G	Lower arm plate
H	Connection plate



Continues on next page

Required equipment

Equipment, etc.	Art. no.	Note
Cable package IRBDP MH2 UE	For spare part number see chapter: <ul style="list-style-type: none"> • Spare parts on page 361. 	A number of variants are available.
Cable package IRBDP SW2 UE	For spare part number see chapter: <ul style="list-style-type: none"> • Spare parts on page 361. 	A number of variants are available.
Standard Toolkit, DressPack	3HAC17290-7	The contents are defined in section Toolkits, DressPack on page 357.
Protective plastic		To protect the connector pins during disassembly.
Other tools and procedures may be required. See references to these procedures in the step-by-step instructions below.		These procedures include references to the tools required.
Circuit diagram	3HAC026209-001	DressPack

Removal

Use this procedure to remove the cable packages IRBDP MH2 UE and IRBDP SW2 UE from the robot, before it is disassembled.

	Action	Note
1	 DANGER Turn off all: <ul style="list-style-type: none"> • electric power supply • hydraulic pressure supply • air pressure supply to the robot, before entering the robot working area.	
2	 CAUTION The cable package is sensitive to mechanical damage. They must be handled with care, especially the connectors, in order to avoid damaging them.	

Continues on next page

4 Repair

4.2.5 Replacing the cable packages IRBDP MH2 UE and IRBDP SW2 UE

Continued

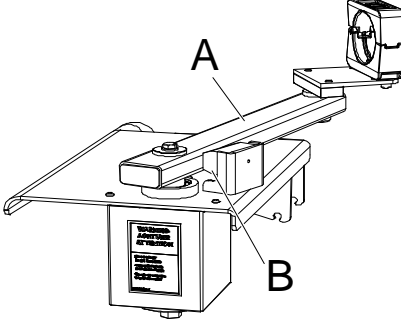
	Action	Note
3	<p> WARNING</p> <p>The tension arm unit pulls the hose package backwards! Hence, in order to avoid accidents, the robot must be positioned in a way that the arm of the tension unit is placed in its rear position.</p> <p>The <i>tension arm</i> must rest on the <i>damper</i> before disassembly of the upper arm harness starts!</p>	 <p>xx0500001794</p> <p>Parts:</p> <ul style="list-style-type: none"> • A: Tension arm • B: Damper
4	Disconnect the hoses from the tool.	
5	Disconnect the cables from the tool.	
6	Open the <i>ball joint housing</i> and remove the cable package from the <i>process cable support, axis 6</i> .	Shown in the figure, Location of the cable packages IRBDP MH2 UE and IRBDP SW2 UE on page 244
7	Disconnect the hoses at the <i>connection plate, lower arm</i> .	Shown in the figure Location of the cable packages IRBDP MH2 UE and IRBDP SW2 UE on page 244 .
8	Disconnect all connectors at the <i>connection plate, lower arm</i> .	Shown in the figure, Location of the cable packages IRBDP MH2 UE and IRBDP SW2 UE on page 244
9	Open the <i>gripping clamp</i> and remove the cable package from the <i>lower arm plate</i> .	Shown in the figure, Location of the cable packages IRBDP MH2 UE and IRBDP SW2 UE on page 244
10	Open the <i>ball joint housing</i> and remove the cable package from the <i>tension arm unit</i> .	Shown in the figure, Location of the cable packages IRBDP MH2 UE and IRBDP SW2 UE on page 244
11	Refit the new or repaired upper cable package.	See section Fitting the cable packages IRBDP MH2 UE and IRBDP SW2 UE on page 88 .

4.2.6 Replacement of cable package IRBDP SW2 CE

Location

This section details how to replace the cable package IRBDP SW2 CE.

Figure shows IRB 6600.

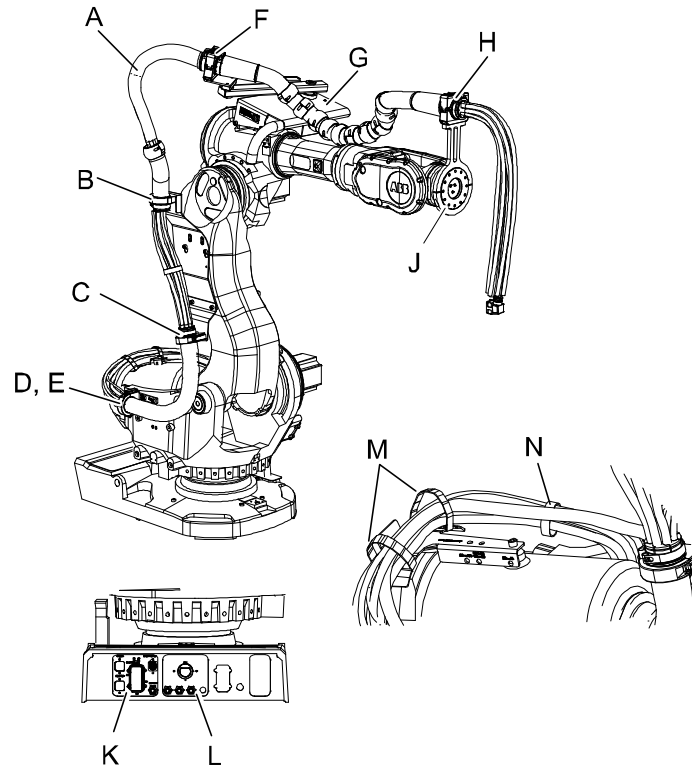

xx0500001445

A	Process cable package
B	Upper gripping clamp (lower arm plate)
C	Lower gripping clamp (lower arm plate)
D	Turn plate
E	Gripping clamp (base)
F	Ball joint housing (tension arm unit)
G	Tension arm unit
H	Ball joint housing (process cable support axis 6)
J	Process cable support axis 6, complete
K	Customer plate
L	Process plate
M	Straps
N	Velcro strap

Continues on next page

4 Repair

4.2.6 Replacement of cable package IRBDP SW2 CE

Continued



Required equipment

The following equipment are required for replacement of the lower/upper arm cable package.

Equipment	Art. no.	Note
Cable package IRBDP SW2 CE		A number of versions are available. See <i>Spare Parts chapter</i> .
Locking liquid	3HAB7116-1	Loctite 243. For locking the gripping clamps.
Standard toolkit, DressPack	3HAC17290-7	The contents are described in section <i>Toolkit, DressPack</i> .
Other tools and procedures may be required. See references to these procedures in the step-by-step instructions below.		These procedures include references to the tools required.
Circuit diagram	3HAC026209-001 3HAC026208-001	

Procedure

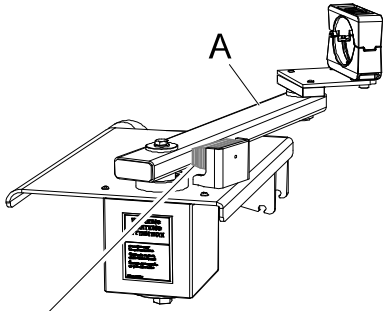
The procedure below details how to remove the cable package IRBDP SW2 CE from the robot, before it is disassembled.

Action	Note
<p>1</p> <p> WARNING</p> <p>In order to avoid accidents place the robot in a service position (upper arm slightly upwards) with the <i>tension arm</i> resting against the <i>damper</i>.</p>	 <p>xx0700000318</p> <p>Parts:</p> <ul style="list-style-type: none"> • A: Tension arm • B: Rubber damper
<p>2</p> <p> DANGER</p> <p>Turn off all:</p> <ul style="list-style-type: none"> • electric power supply • hydraulic pressure supply • air pressure supply <p>to the robot, before entering the robot working area.</p>	

Continues on next page

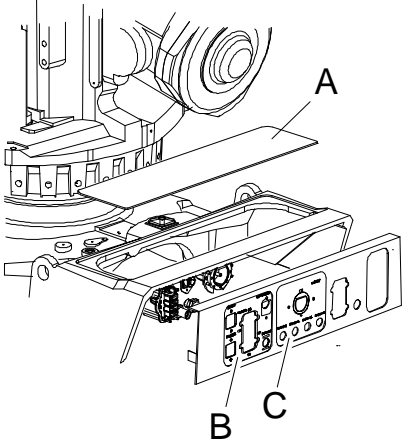
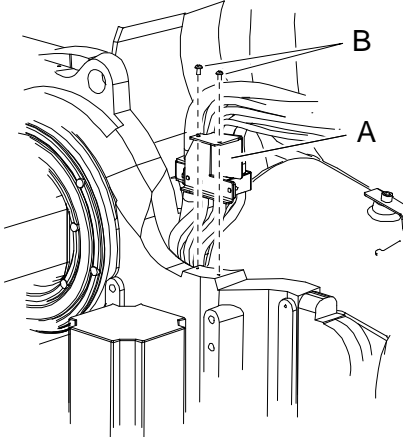
	Action	Note
3	<p> CAUTION</p> <p>The cable package is sensitive to mechanical damage. They must be handled with care, especially the connectors, in order to avoid damaging them.</p>	
4	Disconnect all hoses at tool side.	
5	Disconnect all hoses and connectors from the <i>customer</i> and <i>process plates</i> .	 <p>xx0500001422</p> <p>Parts:</p> <ul style="list-style-type: none"> • A: Cover plate • B: Customer plate • C: Process plate
6	Loosen the complete <i>cable and hose clamp</i> .	 <p>xx0500001421</p> <p>Parts:</p> <ul style="list-style-type: none"> • A: Cable and hose clamp • B: Attachment screw (2 pcs)
7	Pull the <i>cables</i> up through the centrum hole gear box axis 1.	

Continues on next page

4 Repair

4.2.6 Replacement of cable package IRBDP SW2 CE

Continued

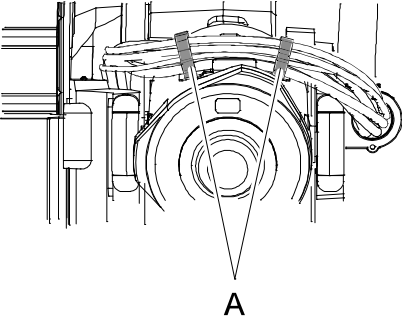
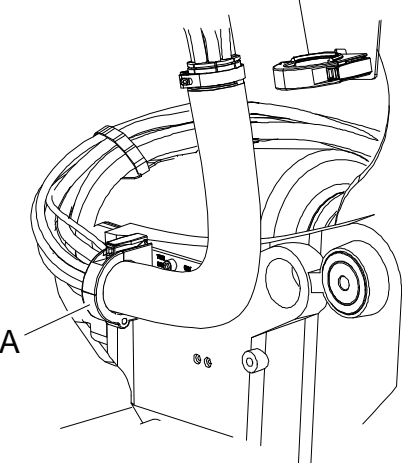
	Action	Note
8	Open the velcro straps and remove the cables and hoses.	 <p>xx0500001424</p> <p>Parts:</p> <ul style="list-style-type: none">A: Velcro straps
9	Open the <i>gripping clamp</i> on the base frame, and remove the cable package.	 <p>xx0500001425</p> <p>Parts:</p> <ul style="list-style-type: none">A: Gripping clamp on base frame.
10	Disconnect all cables at tool side.	

Continues on next page

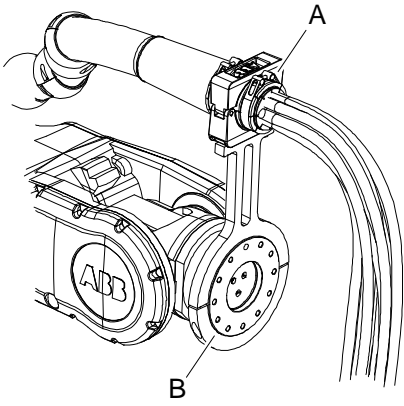
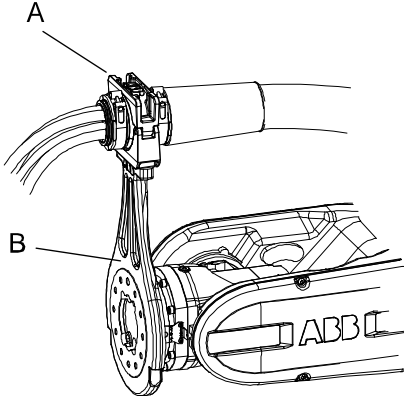
	Action	Note
11	<p>Open the <i>ball joint housing</i> on the <i>process cable support, axis 6</i> and remove the cable package.</p>	<p>The figure shows IRB 7600.</p>  <p>xx0500001438</p> <p>Parts:</p> <ul style="list-style-type: none"> • A: Ball joint housing • B: Process cable support axis 6, complete  <p>xx0600003173</p> <p>Parts:</p> <ul style="list-style-type: none"> • A: Ball joint housing • B: Process cable support axis 6, complete

Continues on next page

4 Repair

4.2.6 Replacement of cable package IRBDP SW2 CE

Continued

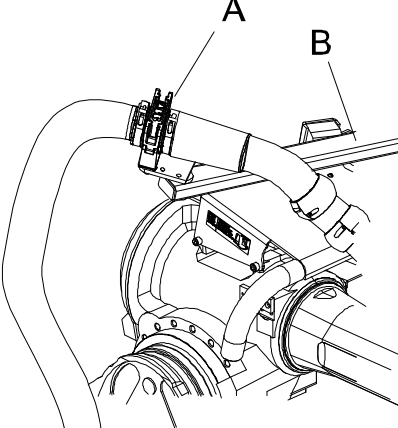
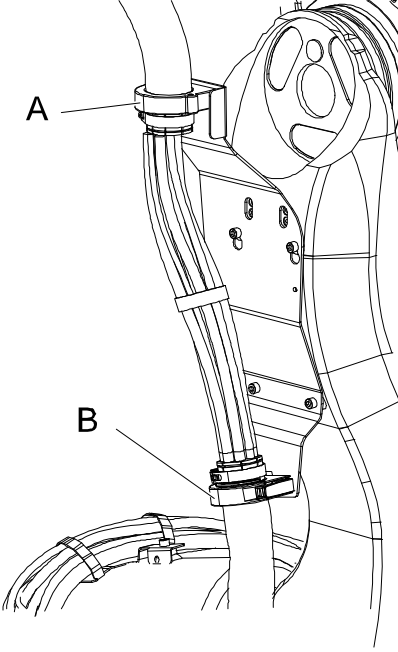
	Action	Note
12	Open the <i>ball joint housing</i> on the <i>tension arm unit</i> , and remove the cable package.	 <p>xx0500001437</p> <p>Parts:</p> <ul style="list-style-type: none">• A: Ball joint housing• B: Tension arm unit
13	Open the upper and lower gripping clamps on the lower arm plate, and remove the cable package.	 <p>xx0500001483</p> <p>Parts:</p> <ul style="list-style-type: none">• A: Upper cable clamp• B: Lower cable clamp
14	Fit the new or repaired cable package.	Detailed in section, Fitting the cable package IRBDP SW2 CE on page 92

4.2.7 Replacing the cable package IRBDP MH3 UE

Location

The cable package IRBDP MH3 UE, is located as shown in the figure.

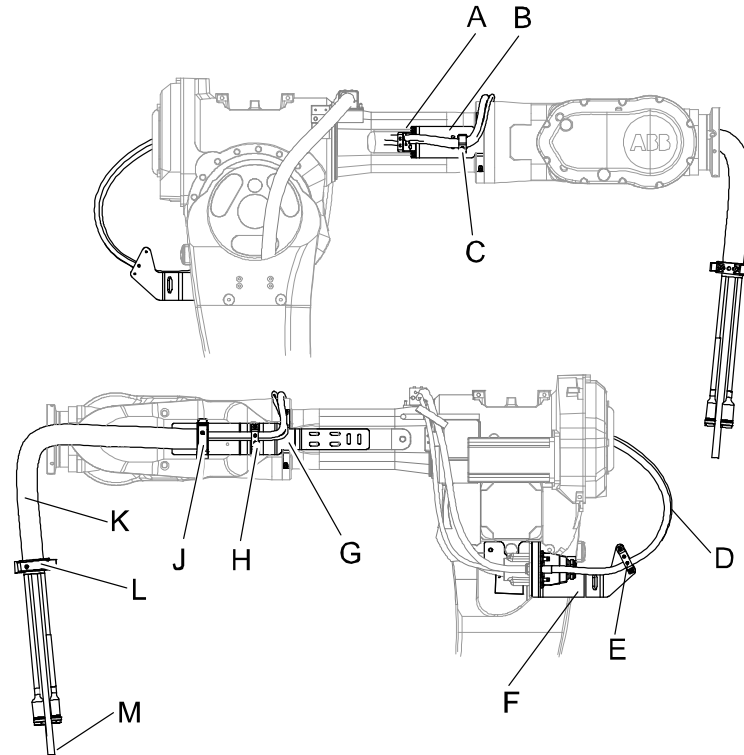

xx0700000379

A	Rubber clamp with bracket
B	Bracket, right
C	Velcro strap
D	Upper arm cable package MH dressing
E	Rubber clamp with bracket
F	Connection plate
G	Bracket, left
H	Rubber clamp with bracket
J	Gripping clamp (bracket left)
K	Protection hose
L	Gripping clamp (protection hose)
M	Air hose

Continues on next page

4 Repair

4.2.7 Replacing the cable package IRBDP MH3 UE

Continued



Required equipment

The following equipment is required for the replacement of the cable package IRBDP MH3 UE.

Equipment	Part no.	Note
Cable package IRBDP MH3 UE	For spare part number see chapter: <ul style="list-style-type: none">Spare parts on page 361.	
Standard toolkit, DressPack	3HAC17290-7	The contents are defined in section Toolkits, DressPack on page 357.
Other tools and procedures may be required. See references to these procedures in the step-by-step instructions below.		These procedures include references to the tools required.
Circuit diagram	3HAC026209-001	See chapter Circuit diagram on page 389.

Procedure

Use this procedure to replace the cable package IRBDP MH3 UE.

	Action	Note
1	 DANGER Turn off all: <ul style="list-style-type: none">electric power supplyhydraulic pressure supplyair pressure supply to the robot, before entering the robot working area.	
2	 CAUTION The cable package is sensitive to mechanical damage. They must be handled with care, especially the connectors, in order to avoid damaging them.	
3	Open the <i>gripping clamp</i> at the front end of the cable package.	Shown in the figure Location on page 253.
4	If the cables has been put in a loop and fitted with straps on the bracket left, remove the straps.	

Continues on next page

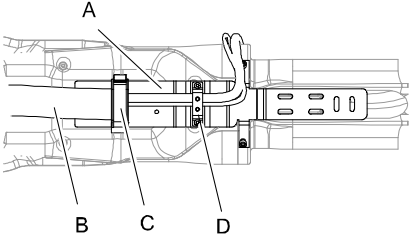
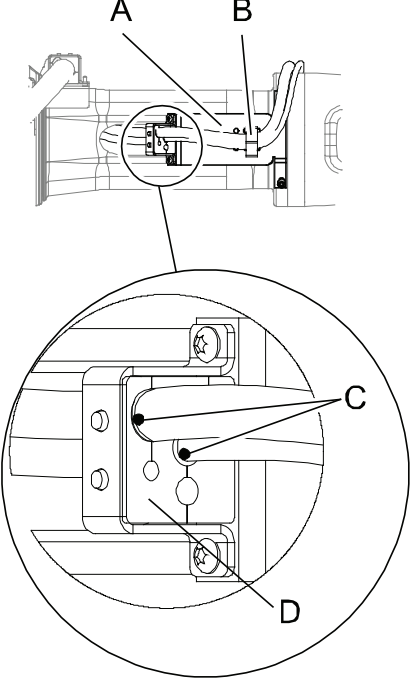
	Action	Note
5	Open the <i>gripping clamp</i> on the <i>bracket left</i> .	 <p>xx0700000372</p> <p>Parts:</p> <ul style="list-style-type: none"> • A: Bracket, left • B: Protection hose • C: Gripping clamp • D: Rubber clamp with bracket
6	Remove the <i>rubber clamp with bracket</i> on the <i>bracket left</i> .	Shown in the figure above.
7	Remove the <i>rubber clamp with bracket</i> on the <i>bracket right</i> . Open the <i>velcro strap</i> .	 <p>xx0700000370</p> <p>Parts:</p> <ul style="list-style-type: none"> • A: Bracket, right • B: Velcro strap • C: White markings on cables • D: Rubber clamp with bracket

Continues on next page

4 Repair

4.2.7 Replacing the cable package IRBDP MH3 UE

Continued

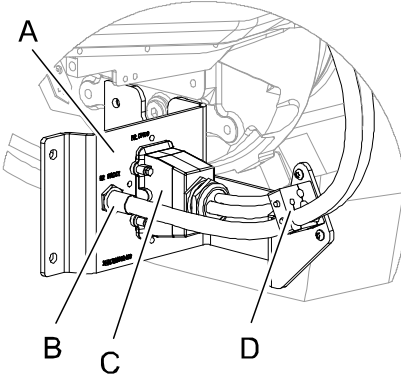
	Action	Note
8	Remove the <i>rubber clamp with bracket</i> on the <i>connection plate</i> and disconnect <i>cables</i> and <i>hose</i> .	 <p>xx0700000368</p> <p>Parts:</p> <ul style="list-style-type: none">• A: Connection plate• B: Hose• C: Signal and power cable• D: Rubber clamp with bracket
9	Pull out the cable package from the upper arm and put it in a safe place.	
10	Refit the new or repaired cable package.	Detailed in section Fitting the cable package IRBDP MH3 UE on page 64.

4.2.8 Replacing the cable package IRBDP SW5 CE (DressPack Basic)

Overview

This procedure describes how to replace the cable package IRBDP SW5 CE (DressPack Basic).

Location of the cable package IRBDP SW5 CE

The cable package IRBDP SW5 CE (DressPack Basic) consists of the parts shown in the figure.

Figure shows IRB 6600.

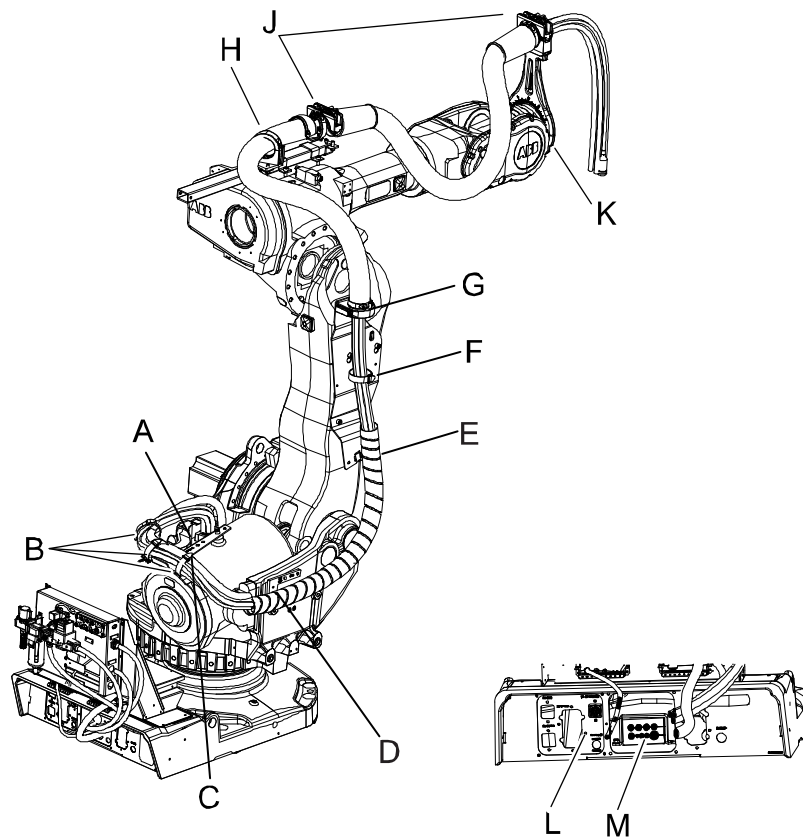

xx080000100

A	Cable and hose clamp
B	Velcro straps
C	Attachment balancing cylinder
D	Spiral hose clamp (turn plate)
E	Spiral hose clamp (lower arm plate)
F	Velcro strap
G	Gripping clamp (lower arm plate)
H	Gripping clamp (adjustable bracket)
J	Ball joint housing
K	Process cable support axis 6

Continues on next page

4 Repair

4.2.8 Replacing the cable package IRBDP SW5 CE (DressPack Basic)

Continued



L	Customer plate
M	Clamp holder with plastic clamp

Required equipment

Equipment	Art. no.	Note
Cable package IRBDP SW5 CE	For spare part number see chapter: <ul style="list-style-type: none">• Spare parts on page 361.	
Standard toolkit, DressPack	3HAC17290-7	The contents are defined in section Toolkits, DressPack on page 357.
Other tools and procedures may be required. See references to these procedures in the step-by-step instructions below.		These procedures include references to the tools required.

Removal

Use this procedure to remove the cable package IRBDP SW5 CE from the robot before it is disassembled.

	Action	Note
1	 DANGER Turn off all: <ul style="list-style-type: none">• electric power supply• hydraulic pressure supply• air pressure supply to the robot, before entering the robot working area.	
2	 CAUTION The cable package is sensitive to mechanical damage. They must be handled with care, especially the connectors, in order to avoid damaging them.	

Continues on next page

4.2.8 Replacing the cable package IRBDP SW5 CE (DressPack Basic)

Continued

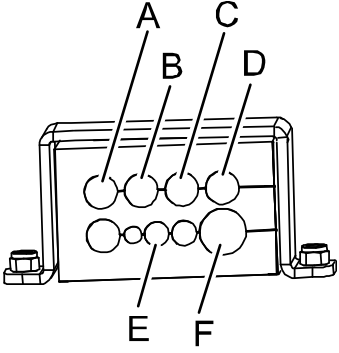
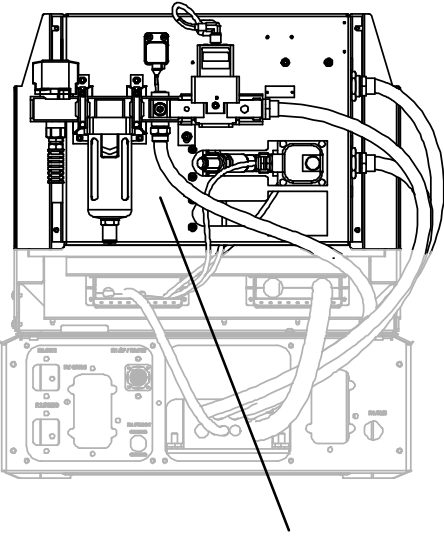
	Action	Note
3	Remove the <i>clamp holder with plastic clamp</i> in the back of the robot base, securing the cable package.	 <p>xx080000079</p> <p>Parts:</p> <ul style="list-style-type: none"> • Clamp holder with plastic clamp
4	Disconnect all cables and hoses at the <i>water and air unit</i> .	 <p>xx080000083</p> <p>Parts:</p> <ul style="list-style-type: none"> • A: Water and air unit

Continues on next page

4 Repair

4.2.8 Replacing the cable package IRBDP SW5 CE (DressPack Basic)

Continued

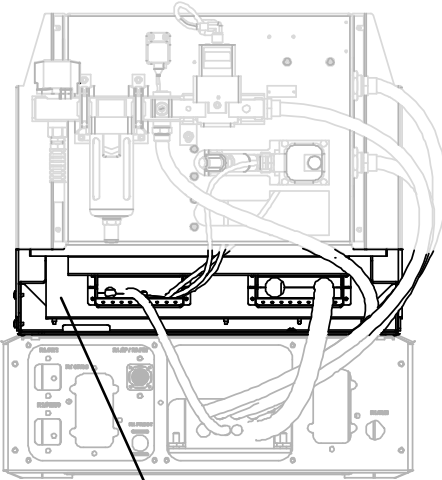
	Action	Note
5	Disconnect all cables and hoses at the <i>connection box</i> .	 <p style="text-align: center;">A</p> <p>xx0800000082</p> <p>Parts:</p> <ul style="list-style-type: none"> A: Connection box
6	Loosen the <i>cable and hose clamp</i> at the bracket axis 1.	Shown in the figure Location of the cable package IRBDP SW5 CE on page 257 .
7	Pull the lower end of the cable package carefully up through the center hole in gearbox axis 1. Order of disassembly: 1 Hoses 2 Signal cables	
8	Loosen the <i>spiral hose clamp</i> on the turn plate.	Shown in the figure Location of the cable package IRBDP SW5 CE on page 257 .
9	Remove the <i>velcro straps</i> at the attachment balancing cylinder and lower arm plate.	Shown in the figure Location of the cable package IRBDP SW5 CE on page 257 .
10	Loosen the <i>spiral hose clamp</i> on the lower arm plate.	Shown in the figure Location of the cable package IRBDP SW5 CE on page 257 .
11	Open the <i>gripping clamp</i> on the lower arm plate.	Shown in the figure Location of the cable package IRBDP SW5 CE on page 257 .
12	Open the <i>gripping clamp</i> on the adjustable bracket.	Shown in the figure Location of the cable package IRBDP SW5 CE on page 257 .
13	Open the <i>ball joint housings</i> at the process cable support axis 6 and adjustable bracket.	Shown in the figure Location of the cable package IRBDP SW5 CE on page 257 .
14	Remove the complete process cable package.	

Continues on next page

Refitting

Use this procedure to remove the cable package IRBDP SW5 CE.

	Action	Note
1	Refitting of the process cable package IRBDP SW 5 CE is described in section Fitting the cable package IRBDP SW5 CE (DressPack Basic) on page 109 .	

4 Repair

4.2.9 Replacing the cable package IRBDP MH LI

4.2.9 Replacing the cable package IRBDP MH LI

Location



xx1500001584

Required parts

Spare part	Article number	Note
Cable package IRBDP MH LI	See DressPack cable package IRBDP MH3 LI on page 376	
Material set IRBDP MH LI	3HAC054825-001	only the Velcro straps





Continues on next page

Required tools and equipment

Equipment	Article number	Note
Standard toolkit		Content is defined in section Standard toolkit on page 357 .

Removing the cable package - IRBDP MH3 LI

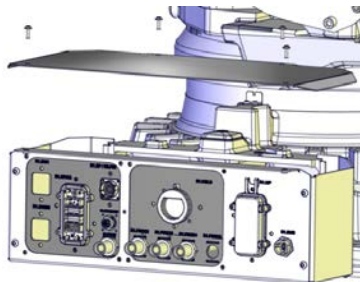
Removing the cable package

	Action	Note
1	Move the robot to a comfortable working position.	
2	 DANGER Turn off all: <ul style="list-style-type: none"> • electric power supply • air pressure supply to the robot, before starting the repair work on the robot.	
3	 CAUTION The cable package is sensitive to mechanical damage. Handle it with care in order to avoid damaging the cabling or the connectors.	
4	Remove the rear top cover.	 xx1400000197
5	Disconnect connectors at the base.	
6	Disconnect the <i>upper cable package</i> connectors at the connection plate.  Note The connection plate is part of the lower cable package.	
7	Open the velcro straps holding the cable package.	From base to connection plate at axis 3-4.

Continues on next page

4 Repair

4.2.9 Replacing the cable package IRBDP MH LI

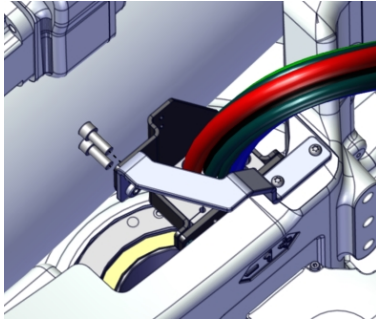
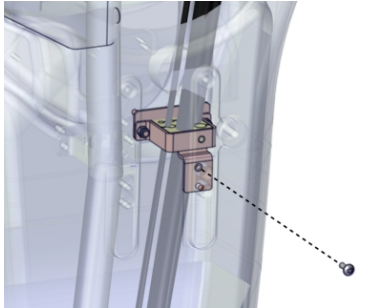
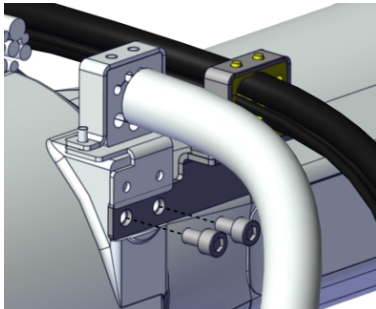
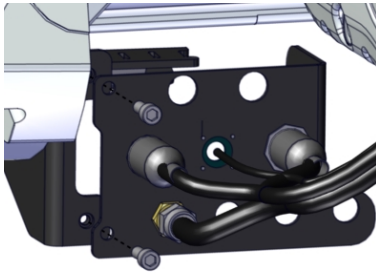

Continued

	Action	Note
8	Remove the screws from the frame adapter plate.	 xx150000896
9	Remove the screws on the lower arm.	 xx1500001594
10	Remove the screws holding the cable bracket on the upper arm.	 xx1500001595
11	Carefully pull out the cable package from the base in the following order: <ul style="list-style-type: none">• Hoses• Cables	
12	Remove the connection plate screws.	 xx1500001596

Continues on next page

Refitting the cable package - IRBDP MH3 LI

Connect the lower cable package at the base

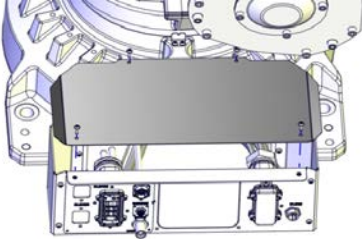
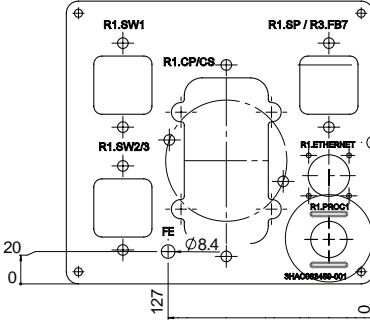
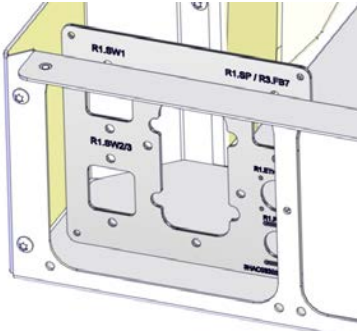
	Action	Note
1	<p> DANGER</p> <p>Turn off all:</p> <ul style="list-style-type: none"> • electric power supply • air pressure supply <p>to the robot, before starting the repair work on the robot.</p>	
2	<p> CAUTION</p> <p>The cable package is sensitive to mechanical damage. Handle it with care in order to avoid damaging the cabling or the connectors.</p>	
3	Remove the rear cover plate.	 <p>xx1400000080</p>
4	<p>Only for Paramulti DressPack and for spare part replacement.</p> <p>The Paramulti DressPack spare part includes functional ground. If the installed DressPack has not included functional ground previously, following action needs to be done:</p> <p>Drill an 8.4 mm mm hole in the customer plate according to the figure.</p>	 <p>xx1900001268</p>
5	Fit the customer plate.	 <p>xx1400001146</p> <p>Screw, M6x16 8.8-A2F (4 pcs)</p>

Continues on next page

4 Repair

4.2.9 Replacing the cable package IRBDP MH LI

Continued

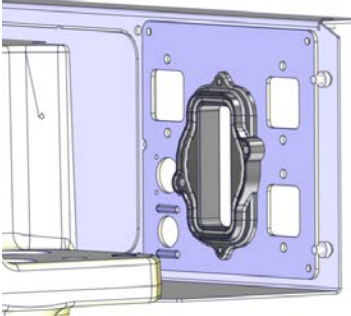
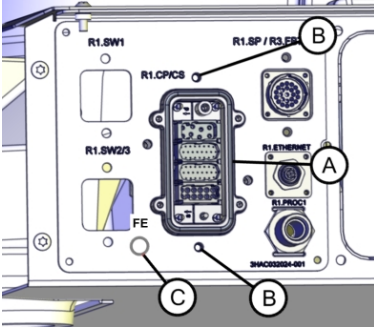
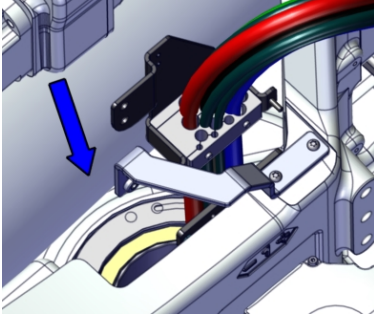
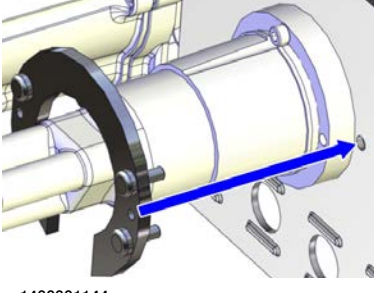
	Action	Note
6	Fit the adapter complete to the customer plate.	 <p>xx1400001140</p>
7	Fasten the adapter complete to the customer plate.	 <p>xx1400001141</p> <p>Parts:</p> <ul style="list-style-type: none"> • A: Adapter complete • B: Attachment screws M6x16 8.8-A2F (2 pcs) • C: Functional ground
8	<p>Run the cables down through the center hole of axis 1, in the following order:</p> <ul style="list-style-type: none"> • Signal cables (Spot welding) • Hoses • Check that the signal cables and hoses do not end up between the motor cables. • Check that cables and hoses do not cross each other or get twisted. 	 <p>xx1500000895</p>
9	Fit the weld connector bracket.	 <p>xx1400001144</p>

Continues on next page

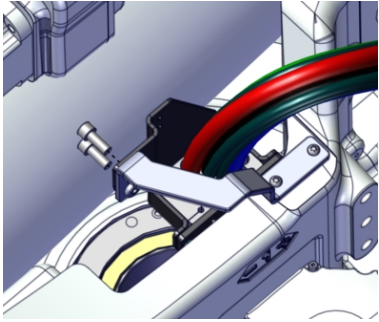
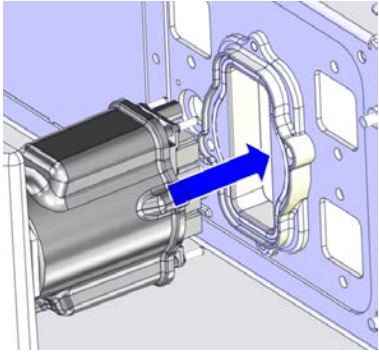
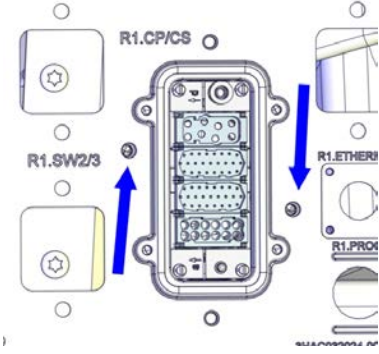



	Action	Note
10	Fasten the cable package bracket to the frame adapter plate. Lock screws with locking liquid, Loctite 243.	 <p data-bbox="1059 636 1166 656">xx150000896</p> <p data-bbox="1059 674 1439 730">Spot welding: Screw, M10x25 8.8-A3-F (2 pcs)</p> <p data-bbox="1059 734 1439 790">Material handling: Screw, M6x16 8.8-A2F (2 pcs)</p>
11	Fit the R1.CP/CS cable to the customer plate.	 <p data-bbox="1059 1158 1166 1178">xx1400001142</p>
12	Secure the R1.CP/CS connector.	 <p data-bbox="1059 1570 1166 1590">xx1400001143</p> <p data-bbox="1059 1608 1390 1628">Screw, M6x20 8.8-A2F (2 pcs)</p>

Continues on next page

4 Repair

4.2.9 Replacing the cable package IRBDP MH LI

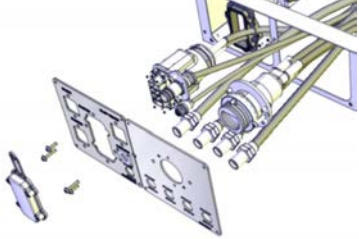
Continued

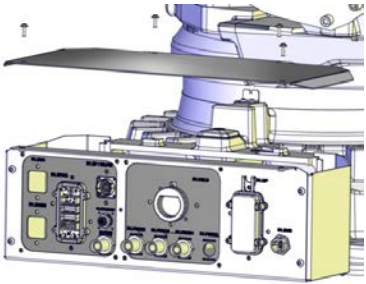
	Action	Note
13	<p>Connect the hose connectors to the customer plate.</p> <p> CAUTION</p> <p>Do not tighten the brass couplings for water and air with excessive force.</p> <p> CAUTION</p> <p>Make sure that no cables or hoses are twisted or strained. Reroute if necessary.</p>	<p>Tightening torque:</p> <ul style="list-style-type: none"> • Brass coupling 1/2": 31 Nm. • Stainless steel coupling 1/2": 49 Nm. • Brass coupling 3/8": 17 Nm. • Mixed metals: Use the lower tightening torque value of the two metals. <p>Always apply Molykote P1900 to stainless steel couplings and apply if needed for couplings of mixed metals or brass.</p>  <p>xx120000088</p>
14	<p>Connect the rest of the cable connectors to the customer plate.</p> <p>Only for Paramulti DressPack: Also connect functional ground.</p> <p> CAUTION</p> <p>Make sure that no cables or hoses are twisted or strained. Reroute if necessary.</p>	
15	<p>Refit the rear cover.</p>	 <p>xx1400000197</p> <p>Screw M6x16 8.8-A2F (4 pcs)</p>

Fitting the cable package

	Action	Note
1	<p> DANGER</p> <p>Turn off all:</p> <ul style="list-style-type: none"> • electric power supply • air pressure supply <p>to the robot, before starting the repair work on the robot.</p>	

Continues on next page

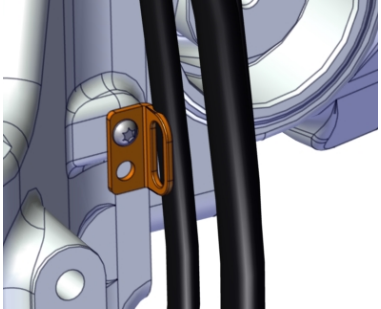
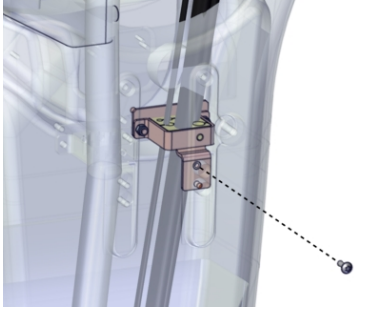
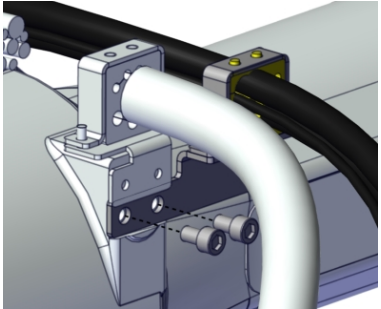

	Action	Note
2	 CAUTION The cable package is sensitive to mechanical damage. Handle it with care in order to avoid damaging the cabling or the connectors.	
3	Fasten cable package with a velcro strap.	 <p>xx1500001593</p>
4	Push the cable package through the inside of the lower arm.	
5	Fasten the cable package to the robot cabling inside the lower arm with velcro straps.	Velcro straps (4 pcs)
6	Fasten the rubber clamp with bracket inside the lower arm.	 <p>xx1500001594</p> <p>Screw M6x16 (1 pcs)</p>
7	Fasten the rubber clamp with bracket on the upper arm.	 <p>xx1500001595</p>

Continues on next page

4 Repair

4.2.9 Replacing the cable package IRBDP MH LI

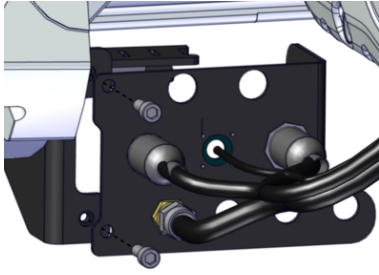
Continued

	Action	Note
8	Fasten the connection plate to mounting plate axis 3.	 <p>xx1500001596</p> <p>Screw M10x25 8.8-A3F (2 pcs)</p>
9	<p>Fasten the connectors and the water couplings on the connector plate.</p> <p> CAUTION</p> <p>Do not tighten the brass couplings for water and air with excessive force.</p> <p> CAUTION</p> <p>If the M12 Ethernet connector is not tightened correctly, there is a risk that the connector can loosen and the cable shield gets disconnected, which will require retightening with the correct torque tools.</p> <p>For secure connection, always tighten at the knurled screw with correct torque and by using proper torque tool, e.g. M12 dynamometric screwdriver SW15 (09 99 000 0646 (article number at Harting Technology Group)).</p>	<p>Tightening torque:</p> <ul style="list-style-type: none"> • Brass coupling 1/2": 31 Nm. • Stainless steel coupling 1/2": 49 Nm. • Brass coupling 3/8": 17 Nm. • Mixed metals: Use the lower tightening torque value of the two metals. <p>Always apply Molykote P1900 to stainless steel couplings and apply if needed for couplings of mixed metals or brass.</p> <p>Tightening torque, Ethernet M12: 0.6 Nm.</p>

4.2.10 Replacing the cable package IRBDP MH3 UI

Location

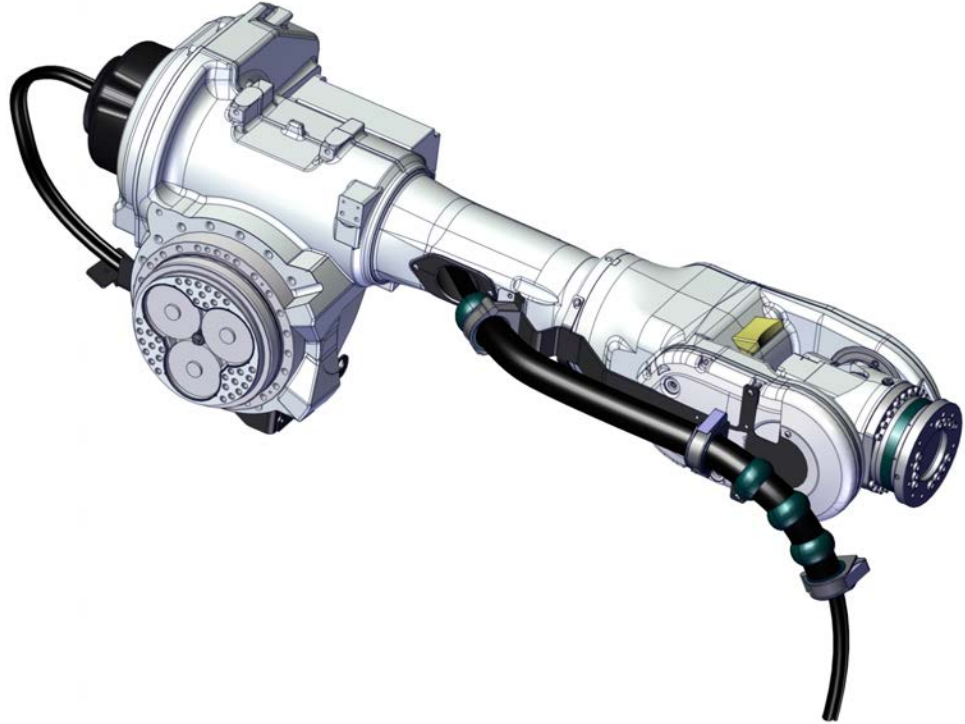

xx1500001579

Required parts

Spare part	Article number	Note
Cable package IRBDP MH3 UI	See DressPack cable package IRBDP MH3 UI on page 379	

Required tools

Equipment	Article number	Note
Standard toolkit		Content is defined in section Standard toolkit on page 357 .

Required consumable

Consumable	Article number	Note
Locking liquid	3HAB7116-1	Loctite 243 For locking attachment screws.



Continues on next page

4 Repair

4.2.10 Replacing the cable package IRBDP MH3 UI

Continued



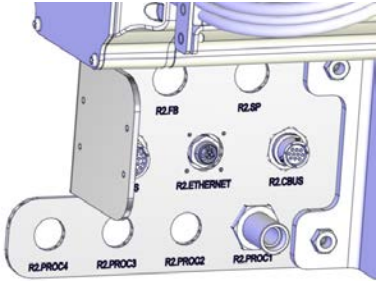
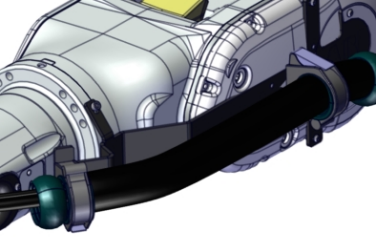
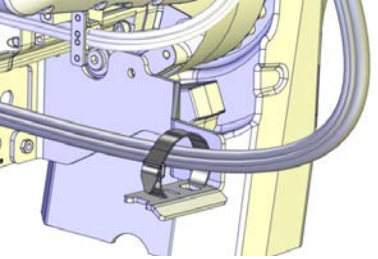

Removing the cable package - IRBDP MH3 UI

	Action	Note
1	 DANGER Turn off all: <ul style="list-style-type: none">• electric power supply• air pressure supply to the robot, before starting the repair work on the robot.	
2	 CAUTION The cable package is sensitive to mechanical damage. Handle it with care in order to avoid damaging the cabling or the connectors.	
3	Disconnect the cable package from the connection plate.	 xx1400000225
4	Open the gripping clamps on the upper arm.	 xx1500001581
5	Open the strap at the bracket.	 xx1400000096

Continues on next page

Refitting the cable package - IRBDP MH3 UI

Route the cable package - Upper arm

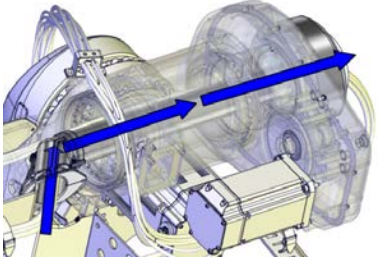
	Action	Note
1	Move the robot to a comfortable working position.	
2	 DANGER Turn off all: <ul style="list-style-type: none"> • electric power supply • air pressure supply to the robot, before starting the repair work on the robot.	
3	 CAUTION The cable package is sensitive to mechanical damage. Handle it with care in order to avoid damaging the cabling or the connectors.	
4	 Tip This procedure is best done by two persons working together - one pushing cabling and hoses into the tube and the other pulling them out at the wrist.	
5	Carefully push the cable package into the insert, through the tube and out in the back of the arm housing.  Tip The following order is preferable: <ol style="list-style-type: none"> 1 Cables 2 Hoses 3 Weld cables (where applicable) 	 xx1400000095

Apply cable grease

It is necessary to apply cable grease on the cable package inside the tube.



	Action	Note
1	Carefully pull the cable package out 10 to 15 centimeters longer than the final assembly position.	

Continues on next page

4 Repair

4.2.10 Replacing the cable package IRBDP MH3 UI

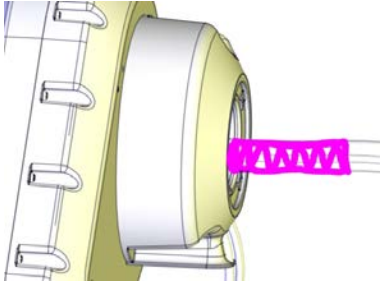
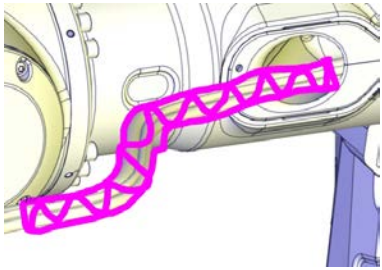
Continued



	Action	Note
2	Apply grease on the highlighted area.	 xx1400001389
3	Carefully push the cable package back into the tube and out through the insert until the area where grease was applied, is visible and able to reach.	
4	Apply grease on the highlighted area, so that the cable package inside the tube is covered with cable grease all the way through.	 xx1400001390
5	Carefully push the cable package back in through the insert and into its mounting position in the tube.	
6	 Note Make sure the cables and hoses are not twisted through the upper arm.	

Apply cable grease

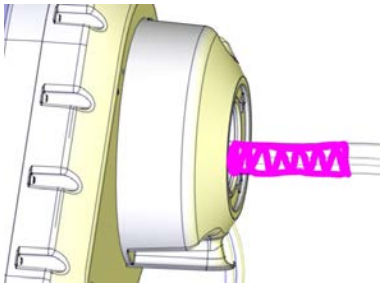

It is necessary to apply cable grease on the cable package inside the tube.

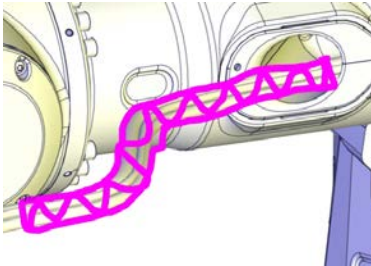
	Action	Note
1	Carefully pull the cable package out 10 to 15 centimeters longer than the final assembly position.	
2	Apply grease on the highlighted area.	 xx1400001389

Continues on next page

	Action	Note
3	Carefully push the cable package back into the tube and out through the insert until the area where grease was applied, is visible and able to reach.	
4	Apply grease on the highlighted area, so that the cable package inside the tube is covered with cable grease all the way through.	 xx1400001390
5	Carefully push the cable package back in through the insert and into its mounting position in the tube.	
6	 Note Make sure the cables and hoses are not twisted through the upper arm.	

Connecting and fitting on the upper arm



	Action	Note
1	 DANGER Turn off all: <ul style="list-style-type: none"> • electric power supply • air pressure supply to the robot, before starting the repair work on the robot.	
2	 CAUTION The cable package is sensitive to mechanical damage. Handle it with care in order to avoid damaging the cabling or the connectors.	

Continues on next page

4 Repair

4.2.10 Replacing the cable package IRBDP MH3 UI

Continued

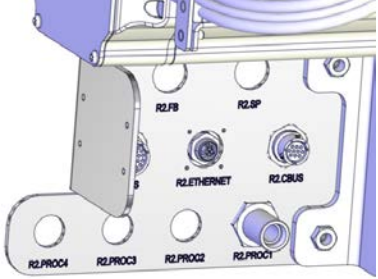
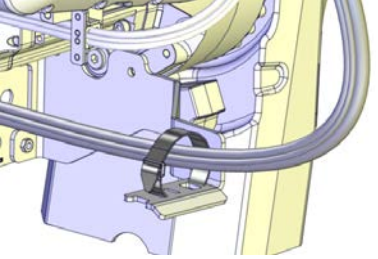
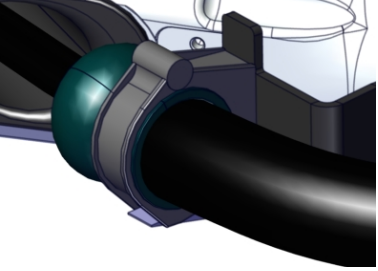
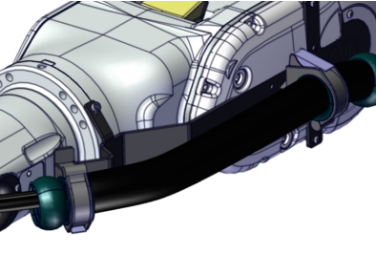
	Action	Note
3	<p>Connect the cable package to the connection plate.</p> <p> CAUTION</p> <p>Do not tighten the brass couplings for water and air with excessive force.</p> <p> CAUTION</p> <p>If the M12 Ethernet connector is not tightened correctly, there is a risk that the connector can loosen and the cable shield gets disconnected, which will require retightening with the correct torque tools.</p> <p>For secure connection, always tighten at the knurled screw with correct torque and by using proper torque tool, e.g. M12 dynamometric screwdriver SW15 (09 99 000 0646 (article number at Harting Technology Group)).</p>	<p>Tightening torque:</p> <ul style="list-style-type: none"> • Brass coupling 1/2": 31 Nm. • Stainless steel coupling 1/2": 49 Nm. • Brass coupling 3/8": 17 Nm. • Mixed metals: Use the lower tightening torque value of the two metals. <p>Always apply Molykote P1900 to stainless steel couplings and apply if needed for couplings of mixed metals or brass.</p> <p>Tightening torque, Ethernet M12: 0.6 Nm.</p>  <p>xx1400000225</p>
4	<p>Fasten the cable package to the bracket with a strap.</p>	 <p>xx1400000096</p>
5	<p>Fasten the cable package in the gripping clamps on the upper arm bracket.</p>	 <p>xx1500001582</p>  <p>xx1500001581</p>

Continues on next page

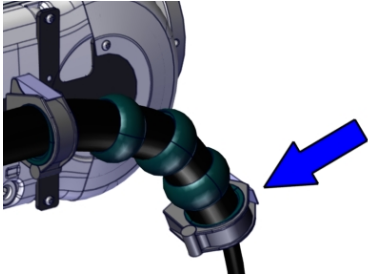
	Action	Note
6	The gripping clamp at the front shall be fitted on equipment used by the customer.	 <p>xx1500001583</p>

4 Repair

4.2.11 Replacing the cable package IRBDP SW6 LE LeanID

4.2.11 Replacing the cable package IRBDP SW6 LE LeanID

Location

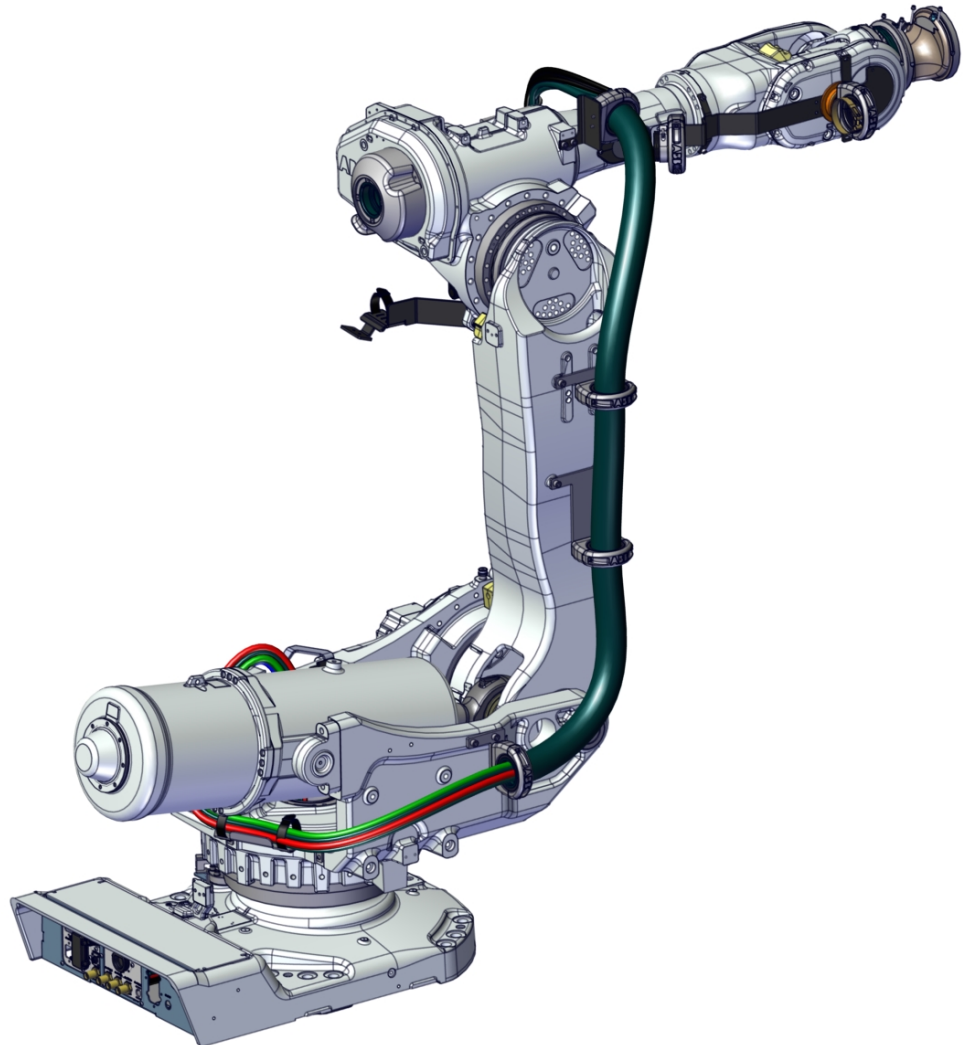

xx150000911

Required parts



Spare part	Article number	Note
Cable package IRBDP SW6 LE	See DressPack cable package IRBDP SW6 LE LeanID on page 375	

Required tools and equipment

Equipment, etc.	Article number	Note
Standard toolkit	-	Content is defined in section Standard toolkit on page 357 .

Continues on next page

Removing the cable package - IRBDP SW6 LE

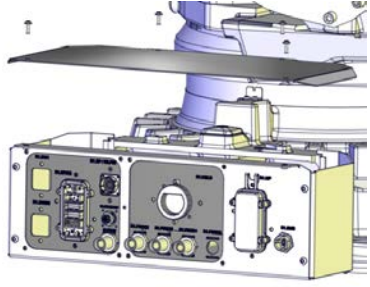
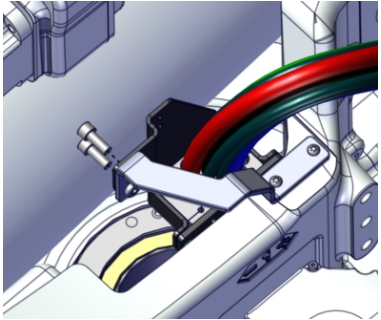



	Action	Note
1	Move the robot to a comfortable working position.	
2	 DANGER Turn off all: <ul style="list-style-type: none"> • electric power supply • air pressure supply to the robot, before starting the repair work on the robot.	
3	 CAUTION The cable package is sensitive to mechanical damage. Handle it with care in order to avoid damaging the cabling or the connectors.	
4	Remove the rear top cover.	 xx1400000197
5	Disconnect connectors at the base.	
6	Open the straps holding the cable package.	From base to connection plate at axis 3-4.
7	Unscrew the screws on the cable package bracket from the axis-1 bracket.	 xx1500000896 Screw, M10x25 8.8-A3-F (2 pcs)
8	Carefully pull out the cable package from the base in the following order: <ul style="list-style-type: none"> • Hoses • Weld cables • Remaining cables 	

Continues on next page

4 Repair

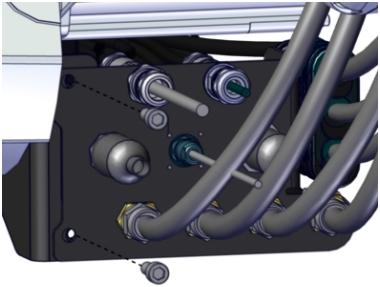
4.2.11 Replacing the cable package IRBDP SW6 LE LeanID

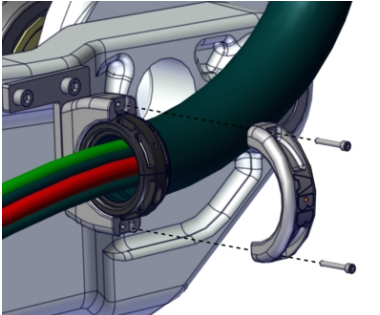

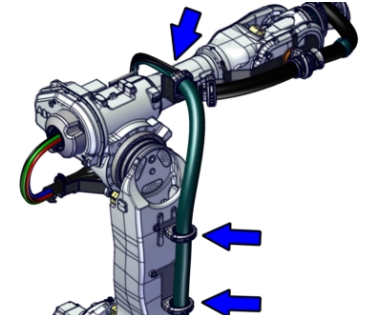
Continued

	Action	Note
9	Disconnect the <i>upper cable package</i> connectors at the connection plate.  Note The connection plate is part of the lower cable package.	
10	Remove the connection plate screws.	 xx150000903 Screw, M10x25 8.8-A3F (2 pcs)
11	Remove the housing upper part of the ball joint housing.  Note Be careful not to loose the small o-ring! The purpose of the o-ring is to keep the screws in place in the housing, upper part.	 xx150000900 Screw, M6x40 8.8-A2F (2 pcs)
12	Remove the cable package from the ball joint housings on the lower arm and on the tubular shaft.  Note Be careful not to loose the small o-ring! The purpose of the o-ring is to keep the screws in place in the housing, upper part.	 xx150000901 Screw, M6x40 8.8-A2F (6 pcs)
13	Put the cable package down.	

Continues on next page

Refitting the cable package - IRBDP SW6 LE

Connect the lower cable package at the base

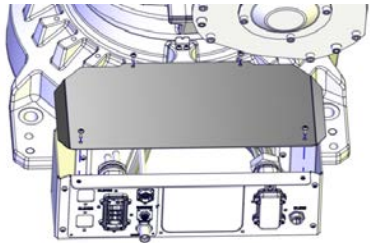
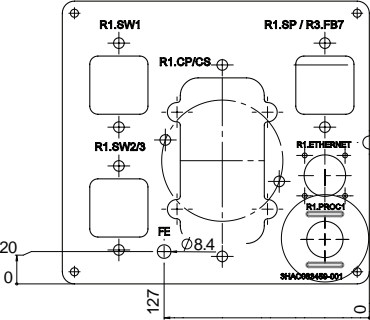
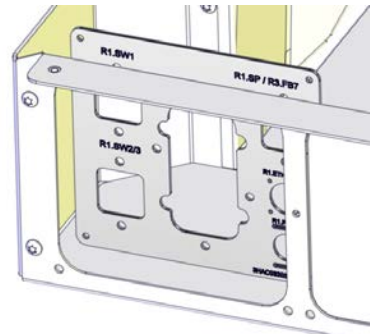
	Action	Note
1	 <p>DANGER</p> <p>Turn off all:</p> <ul style="list-style-type: none"> • electric power supply • air pressure supply <p>to the robot, before starting the repair work on the robot.</p>	
2	 <p>CAUTION</p> <p>The cable package is sensitive to mechanical damage. Handle it with care in order to avoid damaging the cabling or the connectors.</p>	
3	Remove the rear cover plate.	 <p>xx1400000080</p>
4	<p>Only for Paramulti DressPack and for spare part replacement.</p> <p>The Paramulti DressPack spare part includes functional ground. If the installed DressPack has not included functional ground previously, following action needs to be done:</p> <p>Drill an 8.4 mm mm hole in the customer plate according to the figure.</p>	 <p>xx1900001268</p>
5	Fit the customer plate.	 <p>xx1400001146</p> <p>Screw, M6x16 8.8-A2F (4 pcs)</p>

Continues on next page

4 Repair

4.2.11 Replacing the cable package IRBDP SW6 LE LeanID

Continued

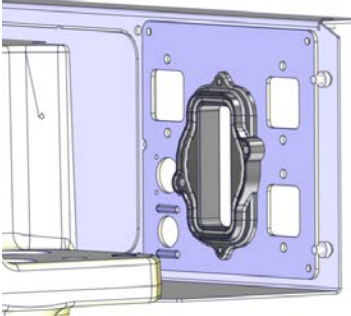
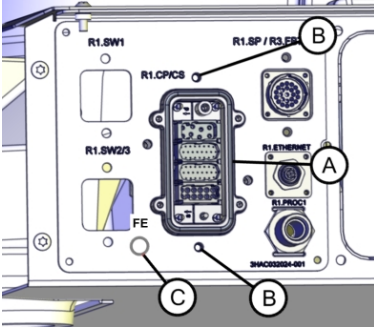
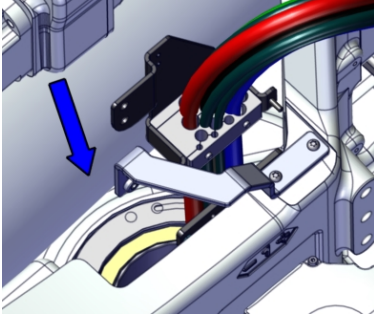
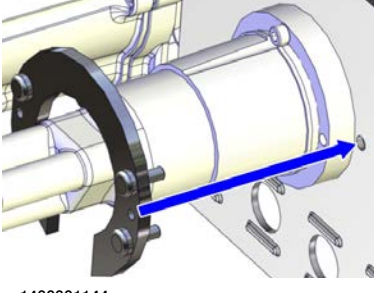
	Action	Note
6	Fit the adapter complete to the customer plate.	 <p>xx1400001140</p>
7	Fasten the adapter complete to the customer plate.	 <p>xx1400001141</p> <p>Parts:</p> <ul style="list-style-type: none">• A: Adapter complete• B: Attachment screws M6x16 8.8-A2F (2 pcs)• C: Functional ground
8	Run the cables down through the center hole of axis 1, in the following order: <ul style="list-style-type: none">• Signal cables (Spot welding)• Hoses• Check that the signal cables and hoses do not end up between the motor cables.• Check that cables and hoses do not cross each other or get twisted.	 <p>xx1500000895</p>
9	Fit the weld connector bracket.	 <p>xx1400001144</p>

Continues on next page

4.2.11 Replacing the cable package IRBDP SW6 LE LeanID

Continued

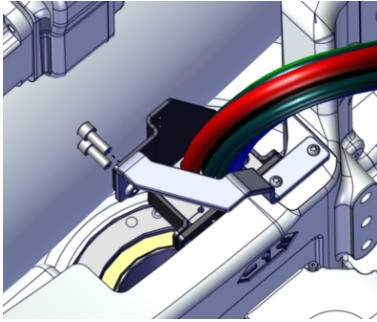
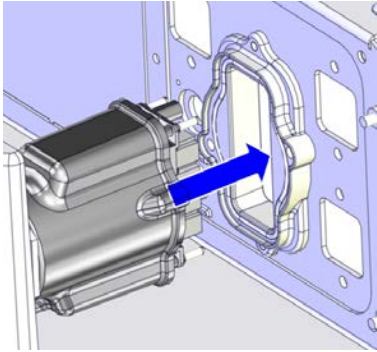
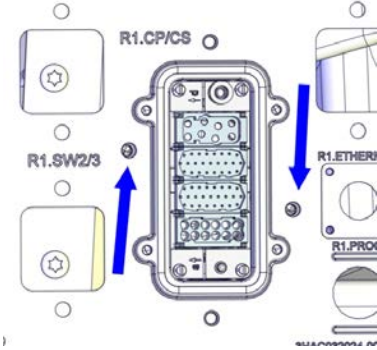



	Action	Note
10	Fasten the cable package bracket to the frame adapter plate. Lock screws with locking liquid, Loctite 243.	 <p>xx1500000896</p> <p>Spot welding: Screw, M10x25 8.8-A3-F (2 pcs) Material handling: Screw, M6x16 8.8-A2F (2 pcs)</p>
11	Fit the R1.CP/CS cable to the customer plate.	 <p>xx1400001142</p>
12	Secure the R1.CP/CS connector.	 <p>xx1400001143</p> <p>Screw, M6x20 8.8-A2F (2 pcs)</p>

Continues on next page

4 Repair

4.2.11 Replacing the cable package IRBDP SW6 LE LeanID

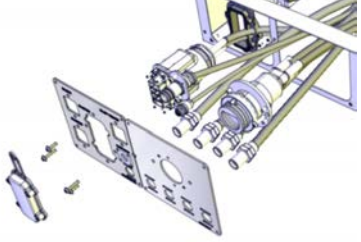
Continued

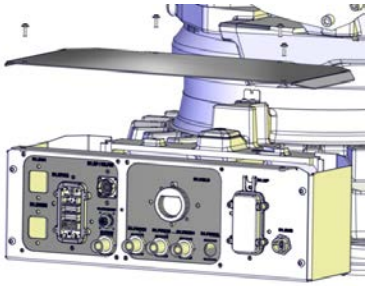
	Action	Note
13	<p>Connect the hose connectors to the customer plate.</p> <p> CAUTION</p> <p>Do not tighten the brass couplings for water and air with excessive force.</p> <p> CAUTION</p> <p>Make sure that no cables or hoses are twisted or strained. Reroute if necessary.</p>	<p>Tightening torque:</p> <ul style="list-style-type: none"> • Brass coupling 1/2": 31 Nm. • Stainless steel coupling 1/2": 49 Nm. • Brass coupling 3/8": 17 Nm. • Mixed metals: Use the lower tightening torque value of the two metals. <p>Always apply Molykote P1900 to stainless steel couplings and apply if needed for couplings of mixed metals or brass.</p>  <p>xx1200000088</p>
14	<p>Connect the rest of the cable connectors to the customer plate.</p> <p>Only for Paramulti DressPack: Also connect functional ground.</p> <p> CAUTION</p> <p>Make sure that no cables or hoses are twisted or strained. Reroute if necessary.</p>	
15	<p>Refit the rear cover.</p>	 <p>xx1400000197</p> <p>Screw M6x16 8.8-A2F (4 pcs)</p>

Fasten the cable package - Lower arm

	Action	Note
1	<p> DANGER</p> <p>Turn off all:</p> <ul style="list-style-type: none"> • electric power supply • air pressure supply <p>to the robot, before starting the repair work on the robot.</p>	

Continues on next page

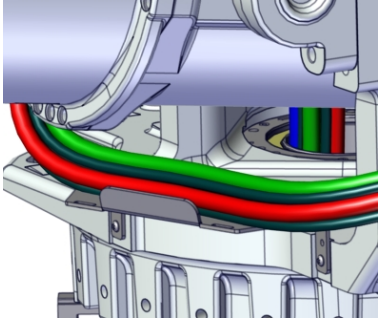
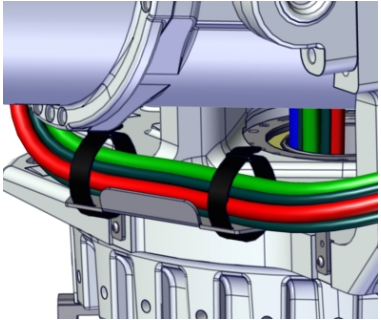
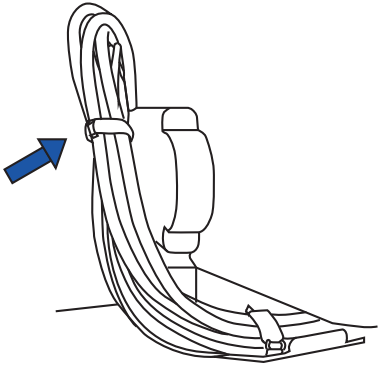

	Action	Note
2	<p> CAUTION</p> <p>The cable package is sensitive to mechanical damage. Handle it with care in order to avoid damaging the cabling or the connectors.</p>	
3	<p>Place the cable package through the cable conduit below the balancing cylinder.</p>	 <p>xx150000899</p>
4	<p>Fasten the cable package with the two straps.</p>	 <p>xx150000898</p>
5	<p>Fasten a velcro strap around the cable package between axis-1 bracket and the cable conduit.</p>	 <p>xx150000897</p>

Continues on next page

4 Repair

4.2.11 Replacing the cable package IRBDP SW6 LE LeanID

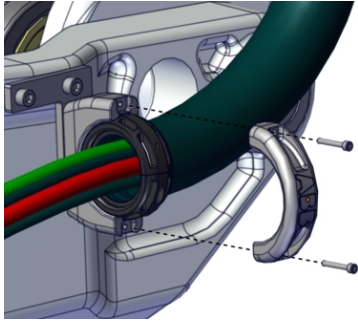
Continued

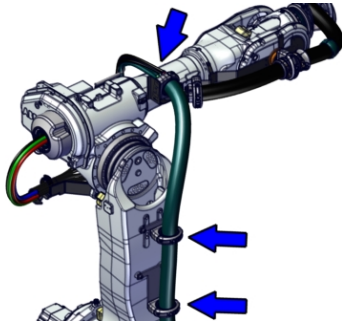
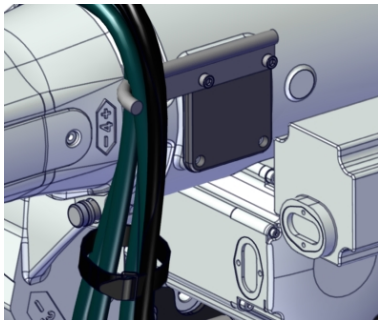
	Action	Note
6	<p>Fasten the cable package in the axis-2 ball joint housing.</p> <p> Note</p> <p>Be careful not to loose the small o-ring! The purpose of the o-ring is to keep the screws in place in the housing, upper part.</p>	 <p>xx1500000900</p> <p>Screw, M6x40 8.8-A2F (2 pcs)</p>
7	<p> CAUTION</p> <p>Do not change the position of the clamp inserts on the protection hose, being fitted in the ball joint housings. If the position is changed it will alter the bending movement of the protection hose, when the arms are moved.</p> <p>A change of position of the clamp inserts may result in serious damage to the cable package.</p>	
8	<p>Fasten the cable package in the ball joint housings on the lower arm and on the tubular shaft.</p>	 <p>xx1500000901</p> <p>Screw, M6x40 8.8-A2F (6 pcs)</p>
9	<p>Put the cable package over the cable guide and fasten it with a velcro strap. Fit another velcro strap around the cable harness.</p>	 <p>xx1500000902</p>

Continues on next page

4.2.11 Replacing the cable package IRBDP SW6 LE LeanID
Continued

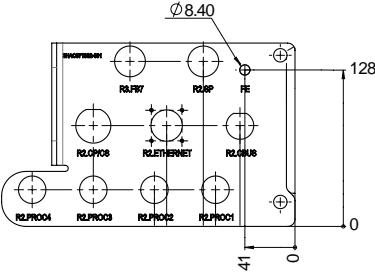
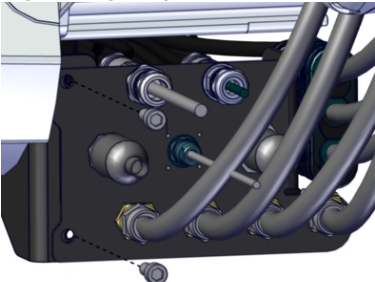
	Action	Note
10	<p>Only for Paramulti DressPack and for spare part replacement.</p> <p>The Paramulti DressPack spare part includes functional ground. If the installed DressPack has not included functional ground previously, following action needs to be done:</p> <p>Drill an 8.4 mm mm hole in the customer plate according to the figure.</p>	 <p>xx1900001269</p>
11	<p>Fasten the connection plate. Lock screws with locking liquid (Loctite 243).</p>	<p>Tightening torque: 47 Nm</p>  <p>xx1500000903</p> <p>Screw M10x25 8.8-A3F (2 pcs)</p>
12	<p>Fit a velcro strap around the cable harness.</p>	

4 Repair

4.2.12 Replacing the cable package IRBDP MH6 UI and IRBDP SW6 UI LeanID

4.2.12 Replacing the cable package IRBDP MH6 UI and IRBDP SW6 UI LeanID

Location

The figure shows the attachments of the cable packages IRBDP SW6 UI and IRBDP MH6 UI.

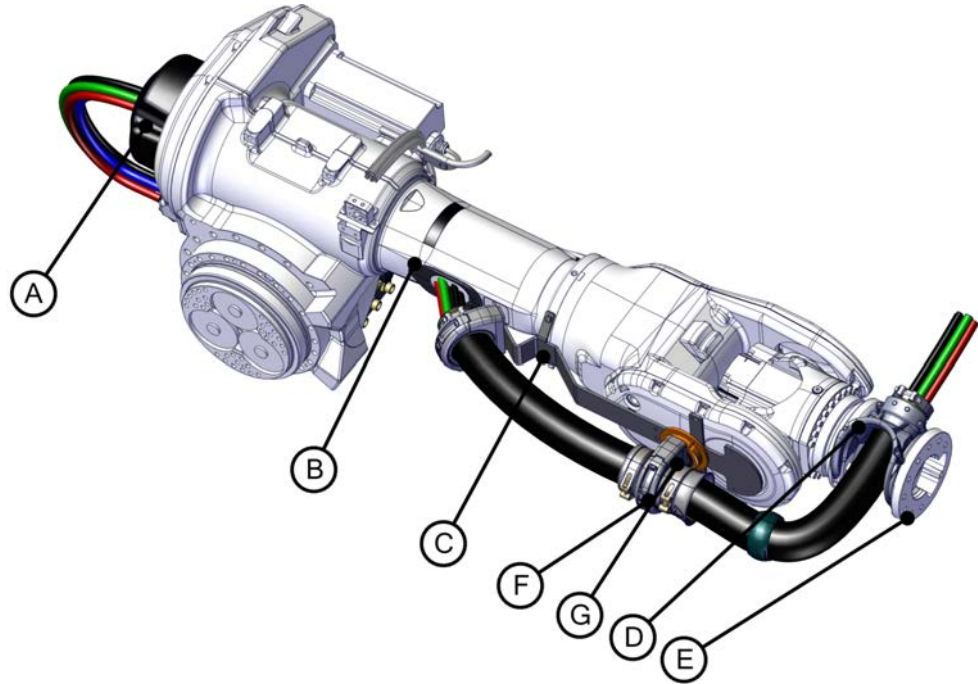

xx150000870

A	Cover
B	Insert (and tube, inside upper arm)
C	Upper arm bracket
D	Axis 6 bracket
E	Process turning disc
F	Ball joint housing
G	Bearing housing

Required parts

Spare part	Article number	Note
Cable package IRBDP MH6 UI or Cable package IRBDP SW6 UI	See DressPack cable package IRBDP MH6 UI LeanID on page 378 DressPack cable package IRBDP SW6 UI LeanID on page 377	

Continues on next page



4.2.12 Replacing the cable package IRBDP MH6 UI and IRBDP SW6 UI LeanID
Continued

Required tools and equipment

Equipment, etc.	Article number	Note
Standard toolkit	-	Content is defined in section Standard toolkit on page 357 .

Removing the cable package - IRBDP MH6 UI and IRBDP SW6 UI

Removing the cable package

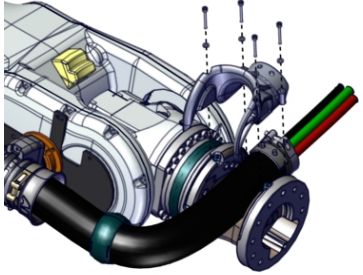
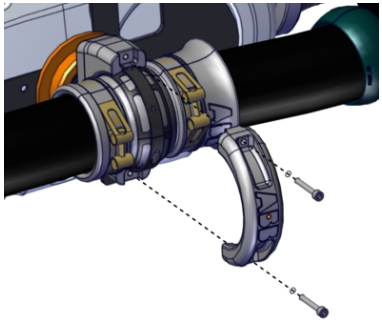
	Action	Note
1	Move the robot to a comfortable working position.	
2	 DANGER Turn off all: <ul style="list-style-type: none"> • electric power supply • air pressure supply to the robot, before starting the repair work on the robot.	
3	 CAUTION The cable package is sensitive to mechanical damage. Handle it with care in order to avoid damaging the cabling or the connectors.	
4	Only valid for IRBDP SW6 UI: Remove the cable package from the process turning disc bracket.	 xx1500000908 Screw, (9ADA183-31) (4 pcs) and washers (4 pcs)
5	Open the ball joint housing upper part.	 xx1500000907 Screw, M6x40 8.8-A2F (2 pcs)

Continues on next page

4 Repair

4.2.12 Replacing the cable package IRBDP MH6 UI and IRBDP SW6 UI LeanID

Continued

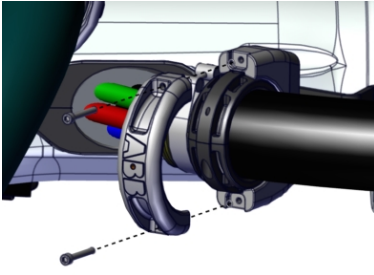
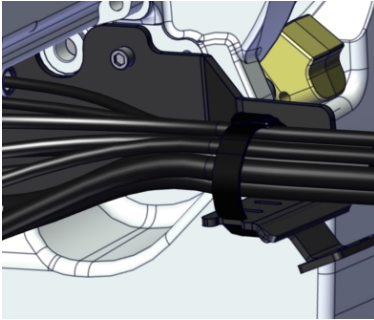
	Action	Note
6	Open the second ball joint housing upper part.	 <p data-bbox="1029 633 1136 654">xx150000905</p> <p data-bbox="1029 674 1361 701">Screw, M6x40 8.8-A2F (2 pcs)</p>
7	Open the straps.	 <p data-bbox="1029 1039 1136 1059">xx150000904</p>

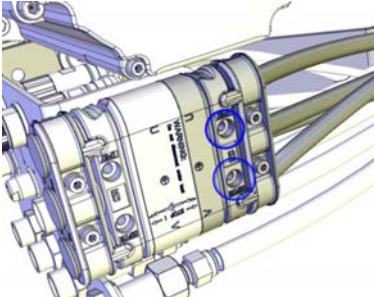
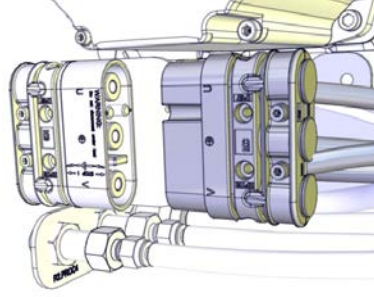

Weld connector

Only valid for IRBDP SW6 UI.

	Action	Note
1	Remove the screws securing the weld connector to the connection plate.	 <p data-bbox="1029 1545 1136 1565">xx120000089</p> <p data-bbox="1029 1585 1361 1612">Screw, M5x40 8.8-A2F (2 pcs)</p>
2	Disconnect the weld connector.	 <p data-bbox="1029 1928 1136 1948">xx120000075</p>

Continues on next page

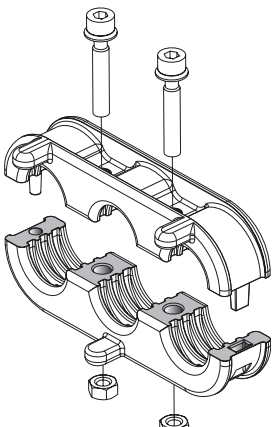
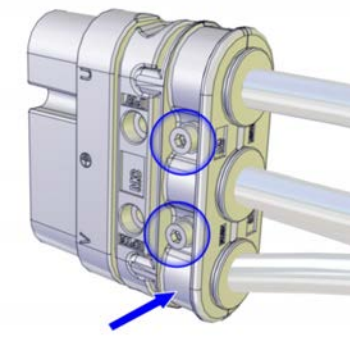
4.2.12 Replacing the cable package IRBDP MH6 UI and IRBDP SW6 UI LeanID
Continued

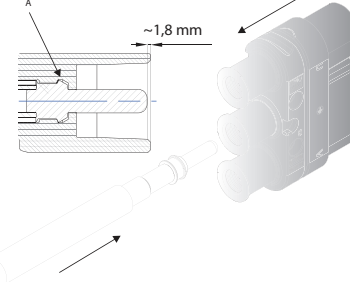
	Action	Note
3	<p>Remove the cable strain relief.</p>  <p>xx1300000836</p> <p>Figure 4.1:</p>	 <p>xx1200000058</p> <p>Screw, M5x25 8.8-A2F (2 pcs)</p>
4	<p>Unplug the connectors in the weld connector. Manually pull the cables with the crimped-on contact part out of the insulation.</p> <p> Note</p> <p>The unplugging will facilitate the removal of the cable package through the tube in the upper arm.</p>	 <p>xx1300000835</p>

Disconnect the cable package

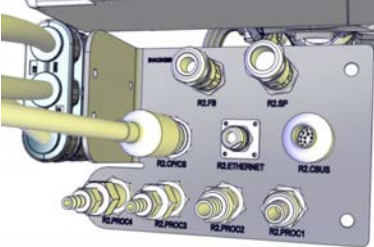
	Action	Note
1	<p>Disconnect hose and cable connectors on the connection plate axis-3 proc.</p>	 <p>xx1200000059</p>





Continues on next page

4 Repair

4.2.12 Replacing the cable package IRBDP MH6 UI and IRBDP SW6 UI LeanID

Continued

Pulling cable package out

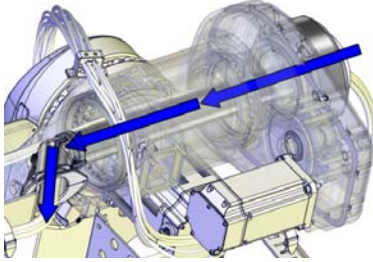
	Action	Note
1	 DANGER Turn off all: <ul style="list-style-type: none"> • electric power supply • air pressure supply to the robot, before starting the repair work on the robot.	
2	 CAUTION The cable package is sensitive to mechanical damage. Handle it with care in order to avoid damaging the cabling or the connectors.	
3	 Tip This procedure is best done by two persons working together - one pushing cabling and hoses into the tube and the other pulling them out at the wrist.	
4	Carefully pull the cable package out through the tube and insert.  Note There is cable grease on the cable package.  Tip The following order is preferable: <ol style="list-style-type: none"> 1 Weld cables 2 Hoses 3 Remaining cables 	 <small>xx1400000188</small>



Refitting the cable package - IRBDP MH6 UI and IRBDP SW6 UI

Route the cable package - Upper arm

	Action	Note
1	Move the robot to a comfortable working position.	
2	 DANGER Turn off all: <ul style="list-style-type: none"> • electric power supply • air pressure supply to the robot, before starting the repair work on the robot.	

Continues on next page

4.2.12 Replacing the cable package IRBDP MH6 UI and IRBDP SW6 UI LeanID
Continued

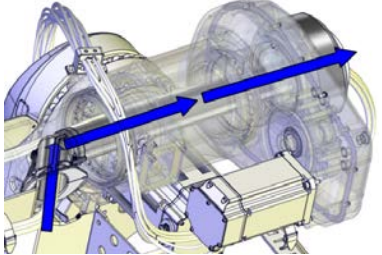
	Action	Note
3	 CAUTION The cable package is sensitive to mechanical damage. Handle it with care in order to avoid damaging the cabling or the connectors.	
4	 Tip This procedure is best done by two persons working together - one pushing cabling and hoses into the tube and the other pulling them out at the wrist.	
5	Carefully push the cable package into the insert, through the tube and out in the back of the arm housing.  Tip The following order is preferable: <ol style="list-style-type: none"> 1 Cables 2 Hoses 3 Weld cables (where applicable) 	 <p>xx140000095</p>

Apply cable grease

It is necessary to apply cable grease on the cable package inside the tube.

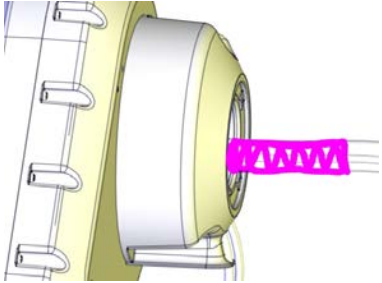

	Action	Note
1	Carefully pull the cable package out 10 to 15 centimeters longer than the final assembly position.	
2	Apply grease on the highlighted area.	 <p>xx1400001389</p>
3	Carefully push the cable package back into the tube and out through the insert until the area where grease was applied, is visible and able to reach.	

Continues on next page

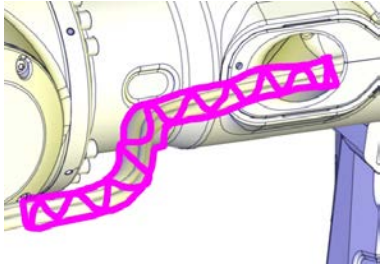

4 Repair

4.2.12 Replacing the cable package IRBDP MH6 UI and IRBDP SW6 UI LeanID

Continued

	Action	Note
4	Apply grease on the highlighted area, so that the cable package inside the tube is covered with cable grease all the way through.	 xx1400001390
5	Carefully push the cable package back in through the insert and into its mounting position in the tube.	
6	 Note Make sure the cables and hoses are not twisted through the upper arm.	

Connect the cable package

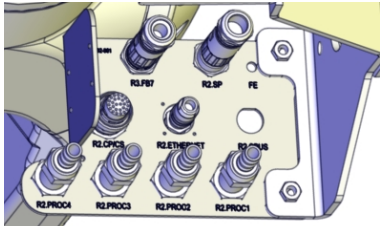
	Action	Note
1	<p>Connect the hose and cable connectors on the connection plate.</p> <p>Only for Paramulti DressPack: Also connect functional ground.</p> <p> CAUTION</p> <p>Do not tighten the brass couplings for water and air with excessive force.</p> <p> Tip</p> <p>Start connecting top connectors, and continue downwards, ending with Proc 4.</p> <p> CAUTION</p> <p>If the M12 Ethernet connector is not tightened correctly, there is a risk that the connector can loosen and the cable shield gets disconnected, which will require retightening with the correct torque tools.</p> <p>For secure connection, always tighten at the knurled screw with correct torque and by using proper torque tool, e.g. M12 dynamometric screwdriver SW15 (09 99 000 0646 (article number at Harting Technology Group)).</p>	<p>Tightening torque:</p> <ul style="list-style-type: none"> • Brass coupling 1/2": 31 Nm. • Stainless steel coupling 1/2": 49 Nm. • Brass coupling 3/8": 17 Nm. • Mixed metals: Use the lower tightening torque value of the two metals. <p>Always apply Molykote P1900 to stainless steel couplings and apply if needed for couplings of mixed metals or brass.</p> <p>Tightening torque, Ethernet M12: 0.6 Nm.</p>  xx1900001267

Continues on next page

4.2.12 Replacing the cable package IRBDP MH6 UI and IRBDP SW6 UI LeanID
Continued

Weld connector

Only valid for IRBDP SW6 UI.

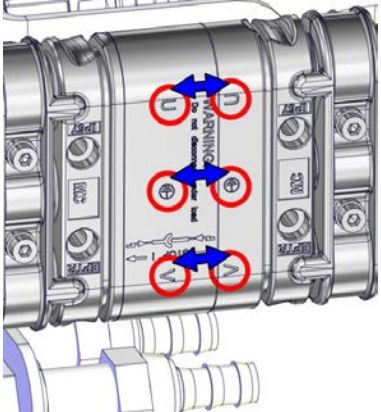
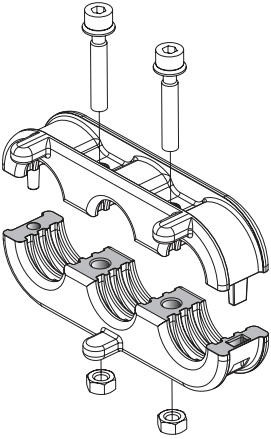
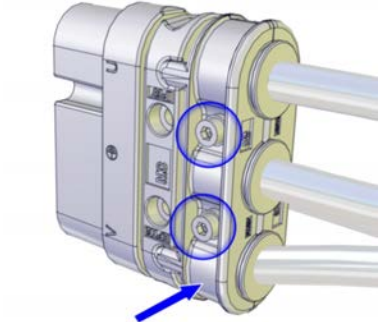
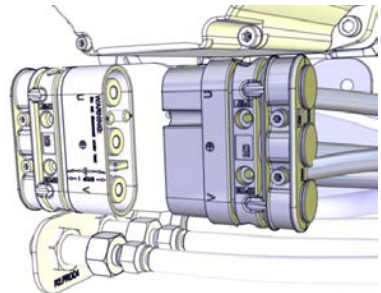
	Action	Note
1	<p>Press (manually) the cables with the crimped-on contact part into the insulation from the back until it perceptibly engages into place to the detent.</p> <p> Note Make sure the pins are pushed all the way into the connector.</p>	 <p>xx1400000216</p>
2	<p>Fit the cable strain relief.</p>  <p>xx1300000836</p>	 <p>xx1200000058 Screw, M5x25 8.8-A2F (2 pcs)</p>
3	<p>Connect the weld cable.</p>	 <p>xx1200000075</p>

Continues on next page

4 Repair

4.2.12 Replacing the cable package IRBDP MH6 UI and IRBDP SW6 UI LeanID

Continued

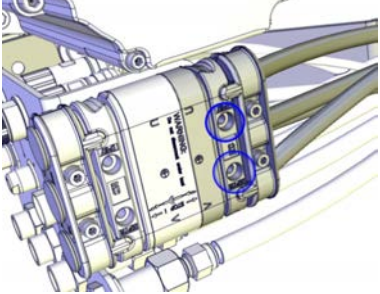

	Action	Note
4	Fasten the weld connector to the connection plate.	 <p data-bbox="1029 616 1141 638">xx120000089</p> <p data-bbox="1029 651 1364 683">Screw, M5x40 8.8-A2F (2 pcs)</p>

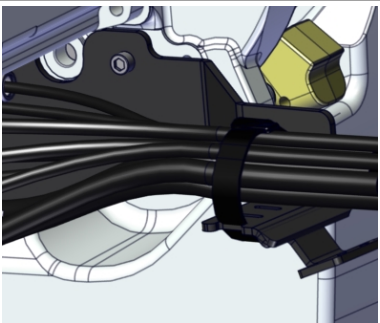
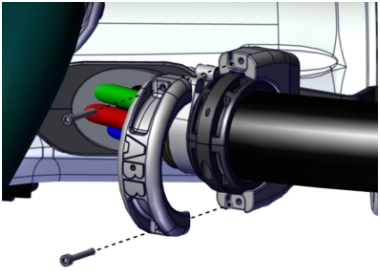
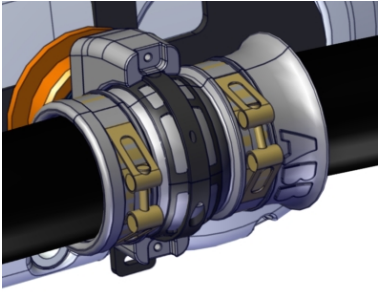
Fasten the cable package

	Action	Note
1	Fasten the cable package to the bracket with a strap.	 <p data-bbox="1029 1131 1141 1153">xx1500000904</p>
2	Fasten the cable package in the ball joint housing.	 <p data-bbox="1029 1505 1141 1527">xx1500000905</p> <p data-bbox="1029 1541 1364 1572">Screw, M6x40 8.8-A2F (2 pcs)</p>
3	Make sure that the hose reinforcement funnel is fitted correctly, in the direction shown in the figure.	 <p data-bbox="1029 1908 1141 1930">xx1500000906</p>

Continues on next page

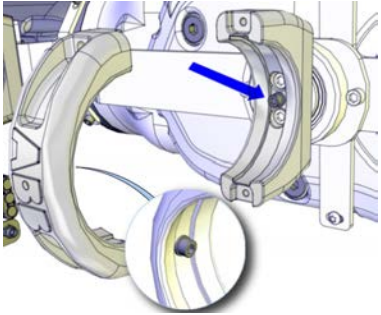
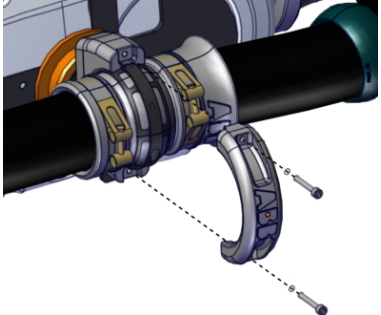
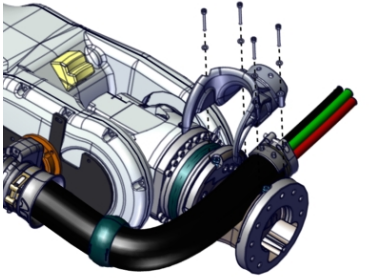
4.2.12 Replacing the cable package IRBDP MH6 UI and IRBDP SW6 UI LeanID
Continued

	Action	Note
4	<p>Make sure that the screws (M6x12) fits into the guiding holes of the hose reinforcement funnel when it is fitted in the ball joint housing.</p> <p> CAUTION</p> <p>The hose reinforcement funnel must not be able to rotate inside the ball joint housing when fitted.</p>	 <p>xx1200000153</p> <p>Screw, M6x12 8.8-A2F (1+1 pcs)</p>
5	<p>Fasten the cable package in the ball joint housing.</p>	 <p>xx1500000907</p> <p>Screw, M6x40 8.8-A2F (2 pcs)</p>
6	<p>Only valid for IRBDP SW6 UI:</p> <p>Fasten the cable package with the process turning disc bracket.</p>	 <p>xx1500000908</p> <p>Screw, (9ADA183-31) (4 pcs) and washers (4 pcs)</p>
7	<p> CAUTION</p> <p>Check potential collision risks between the cable package and the wrist, as well as between the cable package and any equipment fitted on the wrist, before restarting the normal production.</p>	
8	<p>Turn on the power and run the present programming at a very slow speed, while checking all movements for collision risk between cable package and wrist.</p>	
9	<p>Only valid for Paramulti:</p> <p>Connect the functional ground to the customer tool Profinet I/O and or tool changer to increase equipotential bonding.</p>	

Continues on next page

4 Repair

4.2.12 Replacing the cable package IRBDP MH6 UI and IRBDP SW6 UI LeanID

Continued

	Action	Note
10	 DANGER Make sure all safety requirements are met when performing the first test run. See Test run after installation, maintenance, or repair on page 206 .	

Check of protective sleeve

The protective hose is protected against wear in exposed areas with a protective sleeve.

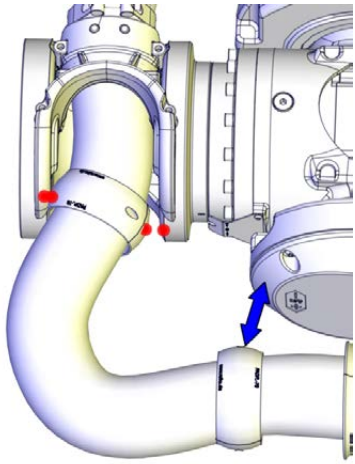
	Action	Note
1	In order to be sure that the protective sleeve is in the correct position, check the position after some hours running.	 xx1400000224
2	If the protective hose is worn somewhere, adjust the position of the protective sleeve.	

4.2.13 Replacement of tension arm unit

Location of tension arm unit

The tension arm is located as shown in the figure.

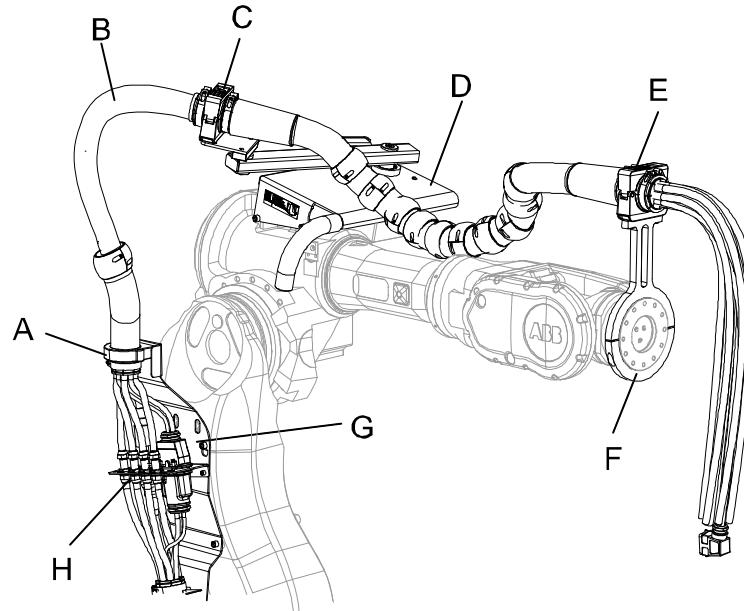

xx0500001490

A	Gripping clamp (lower arm)
B	Process cable package, upper arm
C	Ball joint housing (tension arm unit)
D	Tension arm unit
E	Ball joint housing (process cable support axis 6)
F	Process cable support axis 6, complete
G	Lower arm plate
H	Connection plate

Required equipment

Equipment	Spare part no.	Art. no.	Note
Standard Toolkit, DressPack		3HAC17290-7	The contents are defined in section <i>Toolkits, DressPack</i> on page 357.
Tension arm unit	3HAC022307-001		
Locking liquid		3HAB7116-1	Loctite 243

Continues on next page





4 Repair

4.2.13 Replacement of tension arm unit

Continued

Procedure

The procedure below details how to replace the tension arm unit.

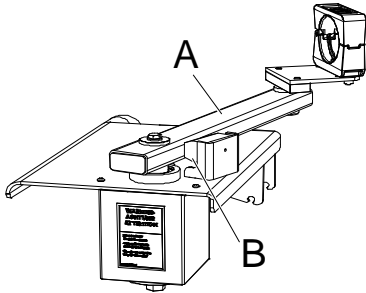
	Action	Note
1	 <p>DANGER</p> <p>Turn off all:</p> <ul style="list-style-type: none"> • electric power supply • hydraulic pressure supply • air pressure supply <p>to the robot, before entering the robot working area.</p>	
2	 <p>CAUTION</p> <p>The cable package is sensitive to mechanical damage. They must be handled with care, especially the connectors, in order to avoid damaging them.</p>	
3	 <p>WARNING</p> <p>The spring inside the tension unit is under tension! Never disassemble the unit! Always exercise care when working with the tension arm unit!</p>	
4	 <p>WARNING</p> <p>In order to avoid accidents place the robot arm in a service position (upper arm slightly upwards) with the <i>tension arm</i> resting against the <i>damper</i>.</p>	 <p>xx0500001794</p> <p>Parts:</p> <ul style="list-style-type: none"> • A: Tension arm • B: Damper
5	Remove the cable package from the ball joint housing on the tension arm unit.	Detailed in section, Replacing the cable packages IRBDP MH2 UE and IRBDP SW2 UE on page 244

Continues on next page

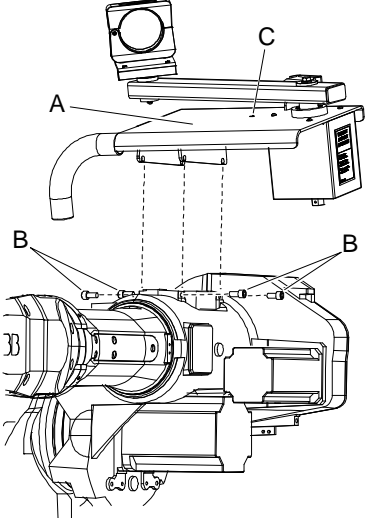
	Action	Note
6	<p>Loosen the <i>attachment screws</i> M12x25 quality 8.8-A3F (4 pcs) holding the <i>tension arm unit</i>.</p> <p>Use the \varnothing 10.2 mm hole to attach a lifting accessory, for example a 10 mm lifting eye with a nut.</p>	 <p>xx0500001433</p> <p>Parts:</p> <ul style="list-style-type: none"> • A: Tension arm unit • B: Attachment screws (4 pcs) • C: \varnothing10.2 mm hole
7	<p>Replace the <i>tension arm unit</i>, and tighten the four <i>attachment screws</i>. Lock screws with locking liquid.</p>	<p>Art. no. is specified in Required equipment on page 299.</p>
8	<p>Refit the cable package.</p>	<p>Detailed in section, Fitting the cable packages IRBDP MH2 UE and IRBDP SW2 UE on page 88</p>

4 Repair

4.2.14 Replacement of damper

4.2.14 Replacement of damper

Location

The damper is located as shown in the figure below.

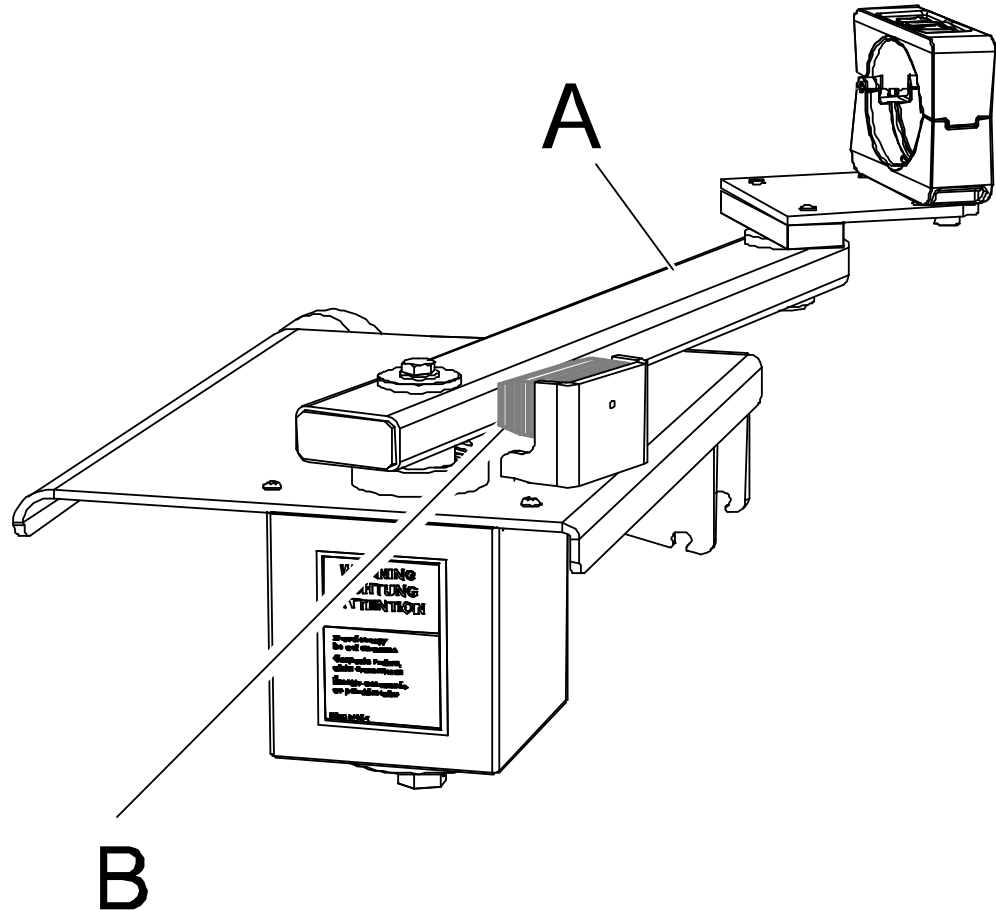

xx0700000318

A	Arm of tension arm unit
B	Damper

Required equipment

Equipment, etc.	Art. no.	Note
Damper	3HAC022307-048	
Standard Toolkit, DressPack	3HAC17290-7	The contents are defined in section Toolkits, DressPack on page 357 .
Other tools and procedures may be required. See references to these procedures in the step-by-step instructions below.		These procedures include references to the tools required.

Continues on next page

Removal

The procedure below details how to remove the damper.

	Action	Note
1	 DANGER Turn off all: <ul style="list-style-type: none"> • electric power supply • hydraulic pressure supply • air pressure supply to the robot, before entering the robot working area.	
2	Pull the arm of the tension arm unit forward by hand to access the damper.	Shown in the figure in section Location on page 302 .
3	Remove the damper by unscrewing the locking nut beneath the damper.	

Refitting

The procedure below details how to refit the damper.

	Action	Note
1	Pull the arm of the tension arm unit forwards by hand, to access the damper.	Shown in the figure in section Location on page 302 .
2	Fit the damper and secure it with its securing nut beneath the damper.	

4 Repair

4.2.15 Replacement of protective sleeves

4.2.15 Replacement of protective sleeves



Note

Protective sleeves are not fitted at delivery!

Location of protective sleeve

The protective sleeves are located as shown in the figure below.

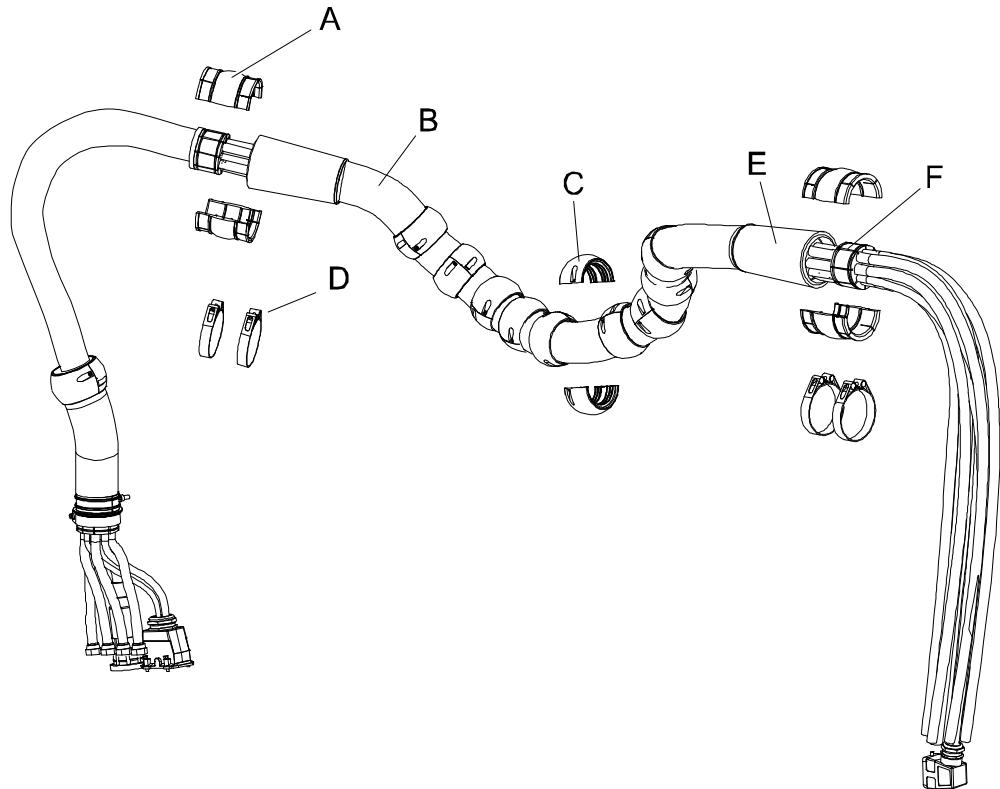

xx0500001549

A	Sliding sleeve
B	Protective hose
C	Protective sleeve
D	Hose clamp
E	Hose reinforcement
F	Rubber retainer
G	Cable star
H	Clamp jaw

Continues on next page



Required equipment

The following equipment are required for replacement of protective sleeves.

Equipment	Art. no.	Note
Protective sleeve	For spare part number see: <ul style="list-style-type: none"> • Spare parts on page 361. For spare part number see chapter Spare parts for cable package on page 368	
Standard toolkit, DressPack	3HAC17290-7	The contents are defined in section Toolkits, DressPack on page 357 .
Other tools and procedures may be required. See references to these procedures in the step-by-step instructions below.		These procedures include references to the tools required.

Procedures

The procedure below details how to change or move the protective sleeves.



	Action	Note
1	 DANGER Turn off all: <ul style="list-style-type: none"> • electric power supply • hydraulic pressure supply • air pressure supply to the robot, before entering the robot working area.	
2	 CAUTION The cable package is sensitive to mechanical damage. They must be handled with care, especially the connectors, in order to avoid damaging them.	

Continues on next page

4 Repair

4.2.15 Replacement of protective sleeves

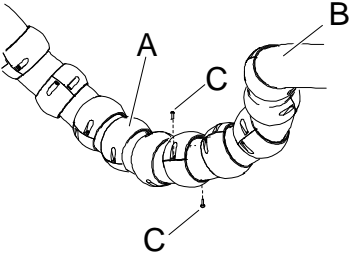
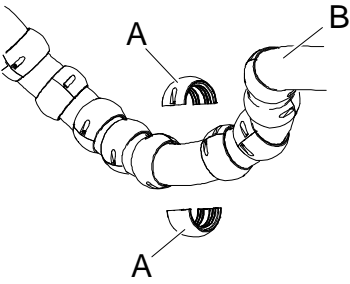
Continued

	Action	Note
3	Remove the two attachment screws.	 <p>xx0500001551</p> <p>Parts:</p> <ul style="list-style-type: none"> • A: Protective sleeve • B: Protective hose • C: Attachment screw (2 pcs)
4	Split the protective sleeve.	 <p>xx0500001550</p> <p>Parts:</p> <ul style="list-style-type: none"> • A: Protective sleeve • B: Protective hose
5	Replace or move the protective sleeve.	
6	 Note When moving or adding protective sleeves, always leave a space between them (approximately the width of one slide sleeve).	
7	Attach the two attachment screws.	

4.2.16 Replacing the protection hose - IRBDP SW6 UI and MH6 UI

Location of protection hose

The protection hose, upper arm, is located as shown in the figure.

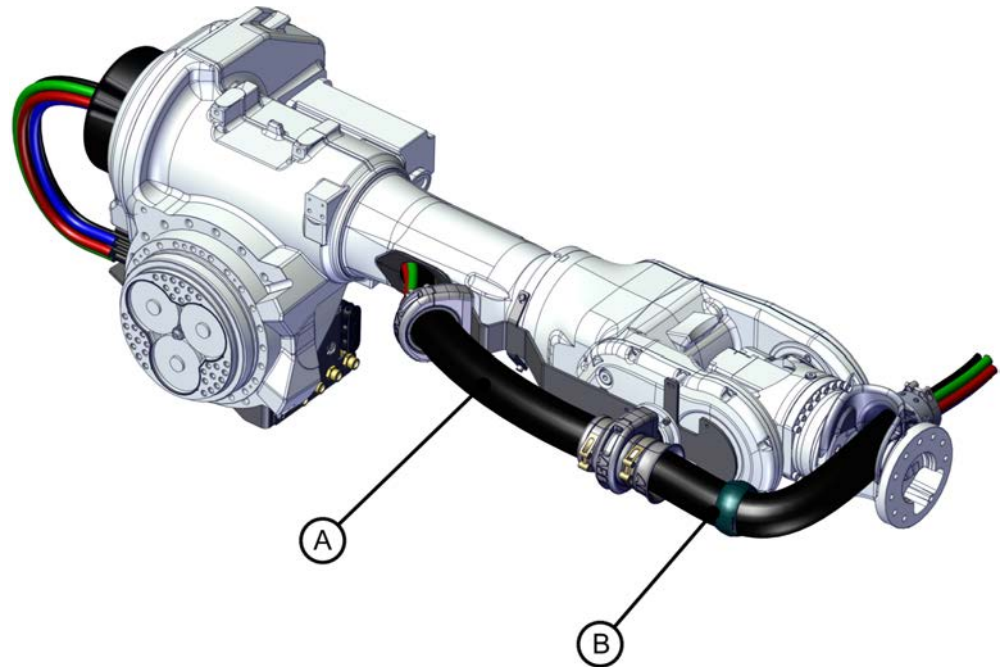

xx1500001641

A	Protection hose, back end
B	Protection hose, front end

Required equipment

Spare parts	Article number	Note
Protection hose, upper arm, front part (1080 mm)	Wear parts on page 381	
Protection hose, upper arm, back part (500 mm)		

Required equipment

Equipment	Article number	Note
Standard toolkit		Content is defined in section Standard toolkit on page 357 .
Other tools and procedures may be required. See references to these procedures in the step-by-step instructions below.		These procedures include references to the tools required.

Continues on next page

4 Repair

4.2.16 Replacing the protection hose - IRBDP SW6 UI and MH6 UI





Continued

Consumable

Consumable	Article number	Note
Cable grease	3HAC14807-1	Optitemp RB 1

Removing the protection hose

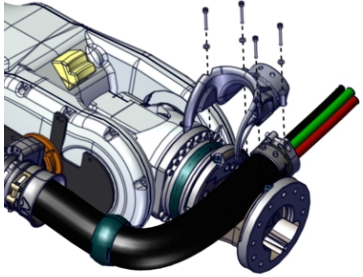
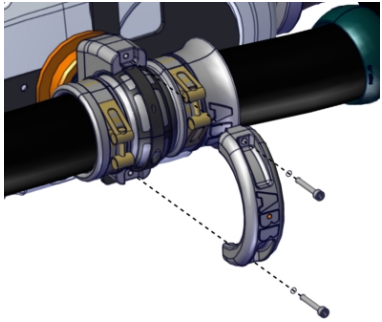

Remove cable guide

	Action	Note
1	Move the robot to a comfortable working position.	
2	 DANGER Turn off all: <ul style="list-style-type: none"> • electric power supply • air pressure supply to the robot, before starting the repair work on the robot.	
3	 CAUTION The cable package is sensitive to mechanical damage. Handle it with care in order to avoid damaging the cabling or the connectors.	
4	Only SW6 (spot welding cables): Remove screws and washers to remove the cable guide.	 xx1500000908
5	Open the ball joint housing.	 xx1500000907
6	 Note Let the cable package stay fitted in the second ball joint housing during the procedure.	

Continues on next page

4.2.16 Replacing the protection hose - IRBDP SW6 UI and MH6 UI
Continued

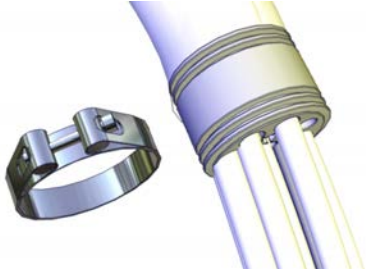
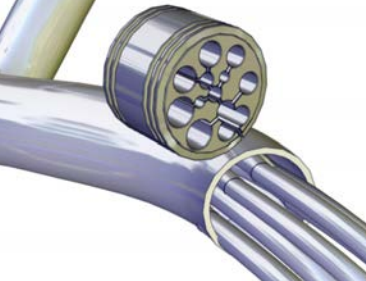
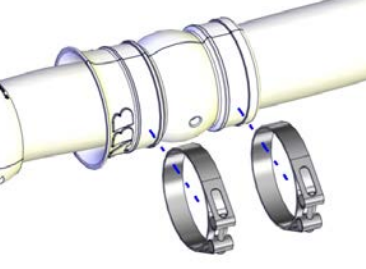
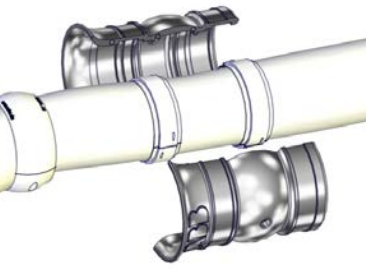
Remove the front part of the protection hose

	Action	Note
1	Remove the hose clamp securing the cable and hose retainer.	 <p>xx1200000159</p>
2	Remove the cable and hose retainer.	 <p>xx1200000103</p>
3	Remove the hose clamps (2 pcs) securing the hose reinforcement funnel.	 <p>xx1400000209</p>
4	Remove the hose reinforcement funnel (two parts).	 <p>xx1400000210</p>
5	<p>Carefully pull the cables and hoses out and remove the front part of the protection hose.</p> <p> Tip</p> <p>The following order is preferred:</p> <ol style="list-style-type: none"> 1 Cables with small connectors 2 Hoses 3 Cables with large connectors 	





Continues on next page

4 Repair

4.2.16 Replacing the protection hose - IRBDP SW6 UI and MH6 UI

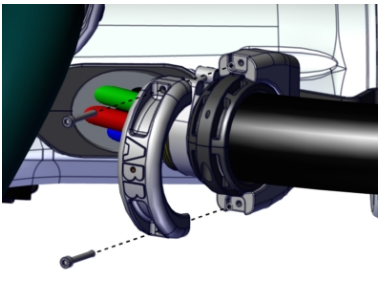
Continued

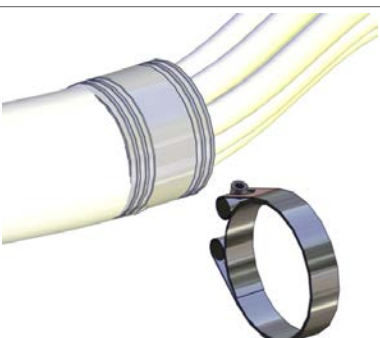
Remove the back end protection hose





	Action	Note
1	Open the ball joint housing at the upper arm tube.	 xx150000905
2	Remove the clamp jaw.	 xx140000347
3	Open the hose clamp securing the cable and hose retainer.	 xx140000348
4	Remove the cable and hose retainer.	 xx140000349

Continues on next page

	Action	Note
5	<p>Carefully pull the cables and hoses out and remove the back end of the protection hose.</p> <p> Tip</p> <p>The following order is preferred:</p> <ol style="list-style-type: none"> 1 Cables with small connectors 2 Hoses 3 Cables with large connectors 	

Refitting the protection hose

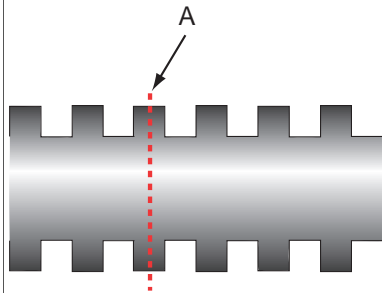
Refit the back part protection hose





	Action	Note		
1	<p> DANGER</p> <p>Turn off all:</p> <ul style="list-style-type: none"> • electric power supply • air pressure supply <p>to the robot, before starting the repair work on the robot.</p>			
2	<p>Cut the new protection hose, back part, to the length required.</p> <p> Note</p> <p>Place the cut on top of a ridge.</p>	 <p>xx0300000061</p> <table border="1" style="width: 100%;"> <tr> <td style="width: 20px; text-align: center;">A</td> <td>Top of a ridge</td> </tr> </table> <p>Length: 500 mm</p>	A	Top of a ridge
A	Top of a ridge			
3	<p>Put some cable grease on cables and hoses on the area where they run through the protection hose and hose reinforcement funnel.</p>			
4	<p>Carefully push cables and hoses into the protection hose.</p> <p> Tip</p> <p>The following order is preferred:</p> <ol style="list-style-type: none"> 1 Cables with large connectors 2 Hoses 3 Cables with small connectors 			
5	<p>Make sure that cables and hoses are not twisted.</p>			

Continues on next page

4 Repair

4.2.16 Replacing the protection hose - IRBDP SW6 UI and MH6 UI

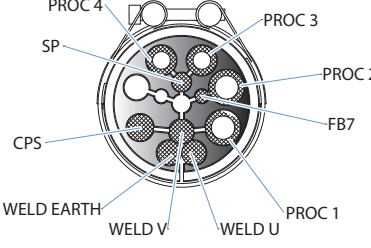
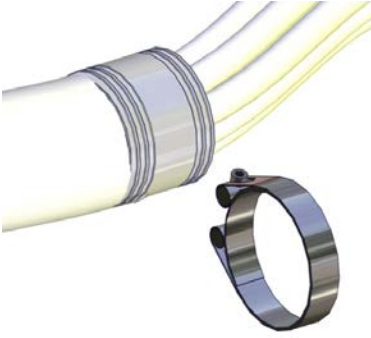
Continued



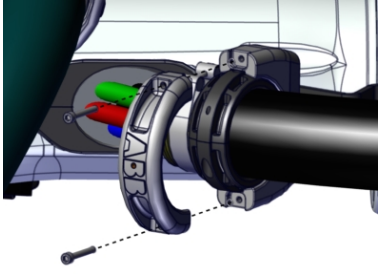

	Action	Note
6	Fit the cable and hose retainer.	 <p>xx1400000349</p>
7	Arrange the cables and hoses and put them in their position in the cable and hose retainer.  Note This is an example showing the Paracom cable harness. If in doubt, see the positions on a cable and hose retainer that is still fitted.	 <p>xx1200000106</p>
8	Secure the cable and hose retainer with the hose clamp.	 <p>xx1400000348</p>
9	Fit the clamp jaw.	 <p>xx1400000347</p>

Continues on next page

4.2.16 Replacing the protection hose - IRBDP SW6 UI and MH6 UI
Continued

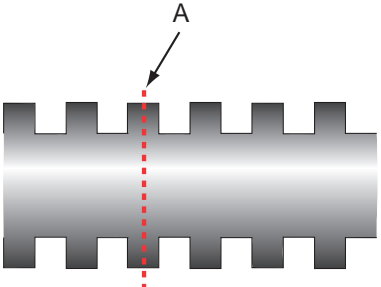
	Action	Note
10	Put the clamp jaw in the ball joint housing.	 <p>xx1500000905</p>

Refit the front part protection hose

	Action	Note		
1	Cut the protection hose, front part, to the length required.  Note Place the cut on top of a ridge.	 <p>xx0300000061</p> <table border="1" data-bbox="1059 1131 1441 1182"> <tr> <td data-bbox="1059 1131 1102 1182">A</td> <td data-bbox="1102 1131 1441 1182">Top of a ridge</td> </tr> </table> <p>Length: 950 mm</p>	A	Top of a ridge
A	Top of a ridge			
2	Carefully push cables and hoses into the protection hose.  Tip The following order is preferred: 1 Cables with large connectors 2 Hoses 3 Cables with small connectors			
3	Make sure that cables and hoses are not twisted.			
4	Fit the middle jaws in one of the hose reinforcement funnel halves.  Note The side of the hose reinforcement funnel that has the bigger outer diameter shall be turned towards the wrist.	 <p>xx1400000350</p>		
5	Fit the other half of the funnel.			

Continues on next page

4 Repair

4.2.16 Replacing the protection hose - IRBDP SW6 UI and MH6 UI

Continued

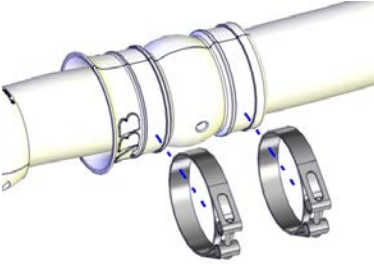
	Action	Note
6	Fasten the hose reinforcement funnel with the hose clamps.	 <p>xx1400000209</p>

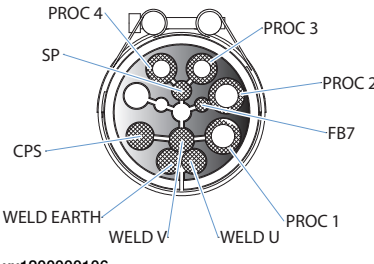
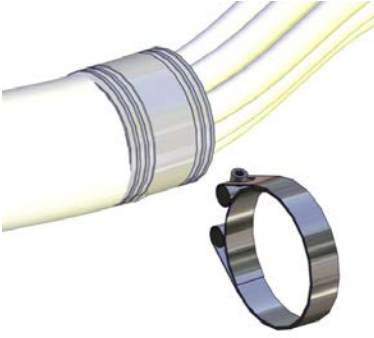

Cable and hose retainer wrist

	Action	Note
1	Arrange the cables and hoses and put them in their position in the cable and hose retainer.  Note This is an example showing the Paracom cable harness. If in doubt, see the positions on a cable and hose retainer that is still fitted.	 <p>xx1200000106</p>
2	Secure the cable and hose retainer with the hose clamp.	 <p>xx1400000348</p>

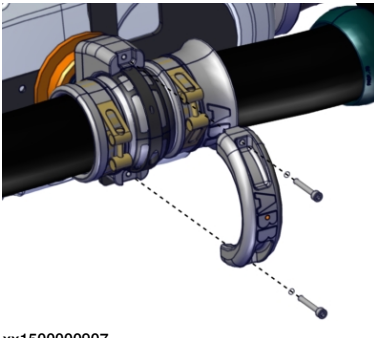
Refit cable package

	Action	Note
1	Fasten the cable package in the ball joint housing.	 <p>xx1500000907</p>

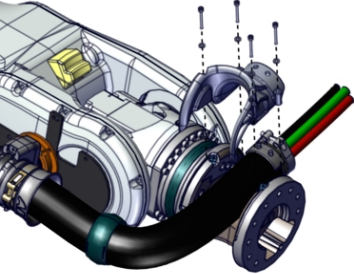
Continues on next page

	Action	Note
2	Only SW6 (spot welding): Fasten cable package with the cable guide.	 xx1500000908
3	 DANGER Make sure all safety requirements are met when performing the first test run. See Test run after installation, maintenance, or repair on page 206 .	

4 Repair

4.2.17 Repair of process cable package

4.2.17 Repair of process cable package



Note

Not applicable to cable packages IRBDP SW6 UI and IRBDP MH6 UI!

General

This section details how to disassemble the DressPack cable package. The actual work may differ due to the type of cables and hoses, the type of connectors etc. However, if differences are distinguishable, these are pointed out in the procedure description.

All work detailed in the procedure below is to be performed on a workbench. How to remove the DressPack from the robot is described in one or more of the sections listed below depending on which cable package is used:

- [Replacing the cable packages - IRBDP MH1 LI and MH2 LI on page 230](#)
- [Replacing the cable packages IRBDP MH2 LE and SW2 LE on page 238](#)
- [Replacing the cable packages IRBDP MH2 UE and IRBDP SW2 UE on page 244](#)
- [Replacement of cable package IRBDP SW2 CE on page 247](#)
- [Replacing the cable package IRBDP MH3 UE on page 253](#)
- [Replacing the cable package IRBDP SW5 CE \(DressPack Basic\) on page 257](#)

Continues on next page

Upper arm cable package parts

The upper arm cable package consists of the parts described in the figure below.

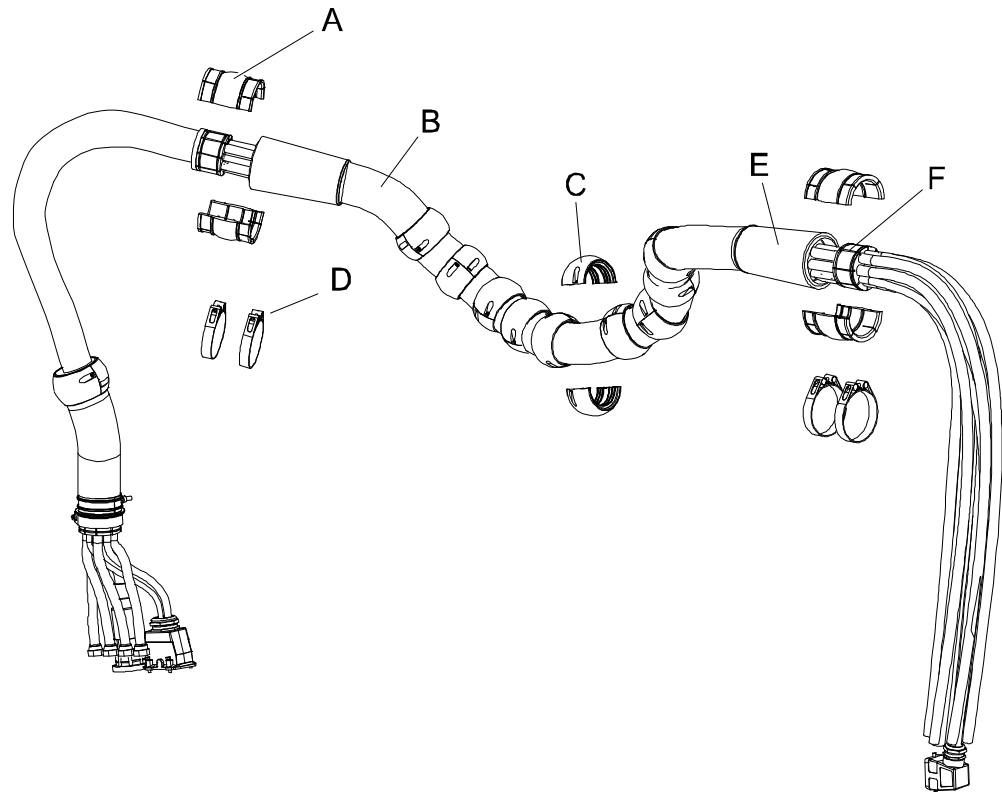

xx0500001549

A	Sliding sleeve
B	Protective hose
C	Protective sleeve
D	Hose clamp
E	Hose reinforcement
F	Rubber retainer
G	Cable star
H	Clamp jaw

Required equipment

Equipment, etc.	Art. no.	Note
Standard Toolkit, DressPack	3HAC17290-7	The contents are defined in section Toolkits, DressPack on page 357 .
Toolkit cables		The contents are defined in section Toolkit cables .
Other tools and procedures may be required. See references to these procedures in the step-by-step instructions below.		These procedures include references to the tools required.

Continues on next page

4 Repair

4.2.17 Repair of process cable package

Continued

Equipment, etc.	Art. no.	Note
Cable grease	3HAC14807-1	Optitemp RB2
Protective plastic	-	To protect the connector pins during disassembly.
Circuit diagram	3HAC026209-001	

Disassembly

The procedure below details how to disassemble the DressPack cable package.

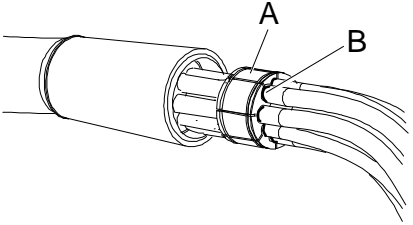



	Action	Note
1	 CAUTION The cable package is sensitive to mechanical damage. They must be handled with care, especially the connectors, in order to avoid damaging them.	
2	Remove the connectors in the tool end.	Use recommended removal tool. Detailed in section <i>Toolkit cables</i> .
3	Put plastic film over the pins and tighten with reinforced tape.	
4	Mark the position for <i>rubber retainer</i> on cables and hoses with <i>reinforced tape</i> .	 <p>xx0500001558</p> <p>Parts:</p> <ul style="list-style-type: none"> • A: Rubber retainer • B: Reinforced tape
5	Fittings might need to be cut to get the package out from protection hose.	
6	Open up the hose clamps in both ends and disassembled <i>slide sleeves</i> .	Shown in the figure, Upper arm cable package parts on page 317
7	Remove the <i>rubber retainer</i> at tool end.	Shown in the figure, Upper arm cable package parts on page 317
8	Slip cables and hoses through protection hose.	
9	Rotate package if stuck. <ul style="list-style-type: none"> • Avoid putting stress to signal cable. 	
10	If tight: <ol style="list-style-type: none"> 1 pull out the hoses one by one 2 pull out the power cable 3 pull out the signal cables. 	
11	Clean cable and hoses from grease.	

Continues on next page

	Action	Note
12	<p>Check carefully if cable and hoses is damaged.</p> <ul style="list-style-type: none"> • Change if required. • Normally, protection hose and hose reinforcement changed at the same time 	

Refitting

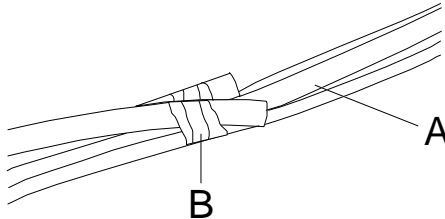
The procedure below details how to refit the DressPack upper arm cable package.





	Action	Note
1	<p> CAUTION</p> <p>The cable package is sensitive to mechanical damage. They must be handled with care, especially the connectors, in order to avoid damaging them.</p>	
2	<p>Do not twist hoses and cables inside the protective hose.</p>	
3	<p>Measure and mark proper position for front and rear rubber retainer with reinforced tape.</p>	
4	<p>Assemble rear rubber retainer.</p> <ul style="list-style-type: none"> • Check the individual order related to the rubber retainer and between the different parts. 	
5	<p>Secure related positions by reinforced tape.</p> <p> Note</p> <p>Put the reinforced tape at parts that will end outside the protective hose.</p>	 <p>xx0500001559</p> <p>Parts:</p> <ul style="list-style-type: none"> • A: Cables and hoses • B: Reinforced tape
6	<p>Apply cable grease on cables and hoses.</p> <p> Note</p> <p>Do not apply grease closer than the 100 mm from cable and rubber retainers, and it is very important that grease is not present on the hoses and cable inside the rubber retainer.</p>	
7	<p>Put cables and hoses on a flat and clean surface.</p>	
8	<p>Straighten weld cable, signal cables and hoses.</p>	

Continues on next page

4 Repair

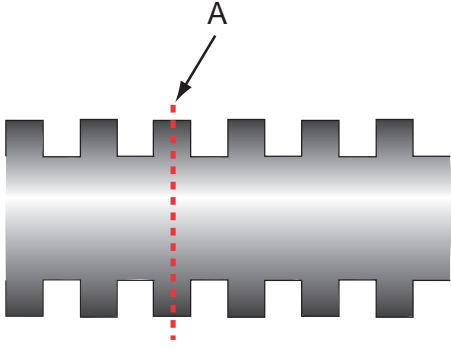
4.2.17 Repair of process cable package

Continued

	Action	Note
9	Inspect the protective hose to make sure its ends has been correctly cut.	 <p>xx030000061</p> <p>Parts:</p> <ul style="list-style-type: none"> A: Place where to cut the protective hose (on top of a ridge).
10	Fit hose reinforcement to protective hose.	See Upper arm cable package parts on page 317
11	Slip cables and hoses inside protective hose.  Note Keep cables and hoses straight during assembly, and not lose orientation relative each other during assembly.	
12	Assemble rubber retainer at the tools side with the same orientation as the rear one.	
13	Remove reinforced tape when slide sleeves are assembled.	
14	Straighten package well and double-check measurements.  Note Protective hose should be measured in released mode and not after being stretched.	
15	Assemble front rubber retainer. <ul style="list-style-type: none"> Open up front rubber retainer on the tool side and push signal cables back 50 mm into the protection hose.  Note The weld cable should not be pushed in the protective hose. Rubber retainers in combination with hoses and weld cable should take the “pulling forces” within the process cable package. The forces should not be transferred to the signal cables.	
16	Fit the slide sleeves.	See Replacement of slide sleeves on page 330 .

Continues on next page

	Action	Note
17	 CAUTION Verify that hoses can withstand 500 N static load without leading to any motion between hoses and rubber retainer relative.	
18	Remove plastic film at the tool end (avoid grease on the pins) and assemble the connectors	Use recommended insertion tool, see <i>Toolkit cables</i> .
19	Check that all cables are connected according to circuit diagram and use the proper tools	See <i>Toolkits, DressPack on page 357</i>
20	Check that the strain relief for the cables are correct.	
21	Mount the fittings on the hoses and double check for leakage.	
22	If protective sleeves has been fitted, refit them at the same position as before.	
23	The package is ready for assembly on the robot.	

4 Repair

4.2.18 Adjusting tension arm unit

4.2.18 Adjusting tension arm unit



Note

This section is not applicable to cable packages IRBDP SW6 UI and IRBDP MH6 UI.

Location of tension arm unit

This section describes how to adjust the tension arm unit.

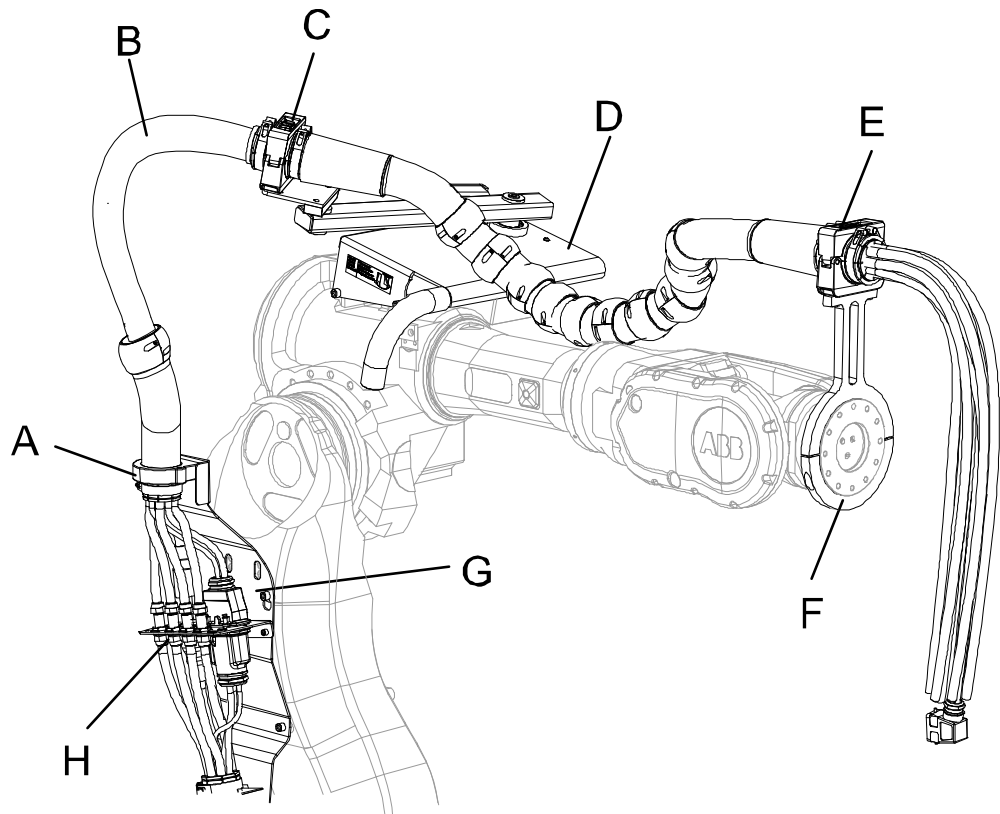

xx0500001490

A	Gripping clamp (lower arm)
B	Process cable package, upper arm
C	Ball joint housing (tension arm unit)
D	Tension arm unit
E	Ball joint housing (process cable support axis 6)
F	Process cable support axis 6, complete
G	Lower arm plate
H	Connection plate

General

Spring tension has influence on lifetime of the upper arm harness and shall not be higher than necessary.

Continues on next page

Tension is optimized for normal length of upper arm harness working vertically.

- The arm of the tension unit shall "float" a little when the robot is moving. Short upper arm harness for working horizontally may need less tension. Long upper arm harness on shelf mounted robots may need a higher tension.

Required equipment

Equipment	Note
Standard tool kit DressPack	The contents are defined in section Toolkits, DressPack on page 357 .
Wrench 27 mm with extended shaft	To manage holding the spring force properly during adjustment, the wrench needs to have an extended shaft (approximately 0.5 m).

Adjustment values

At delivery all tension arm are pre-tensioned 3/4 of a turn.



Spring force must be adjusted to fit valid cycle. Approximate values:

- Spot welding ~ 3/4 turn
- Material Handling ~ 1/2 - 3/4 turn

Adjusting tension arm unit

The procedure below details how to adjust the tension arm unit spring.

Loosening the spring

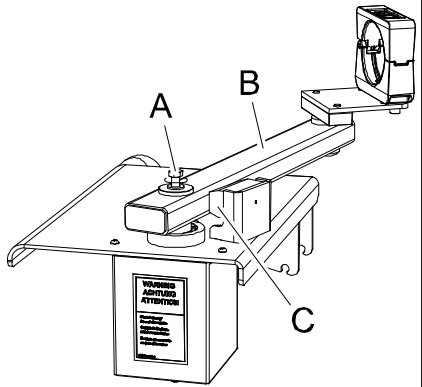



	Action	Note
1	 <p>DANGER</p> <p>Turn off all:</p> <ul style="list-style-type: none"> • electric power supply • hydraulic pressure supply • air pressure supply <p>to the robot, before entering the robot working area.</p>	
2	 <p>WARNING</p> <p>In order to avoid accidents place the robot in a service position (upper arm slightly upwards) with the <i>tension arm</i> resting against the <i>damper</i>.</p>	 <p>xx0500001503</p> <p>A Upper screw M12 B Tension arm C Damper</p>

Continues on next page

4 Repair

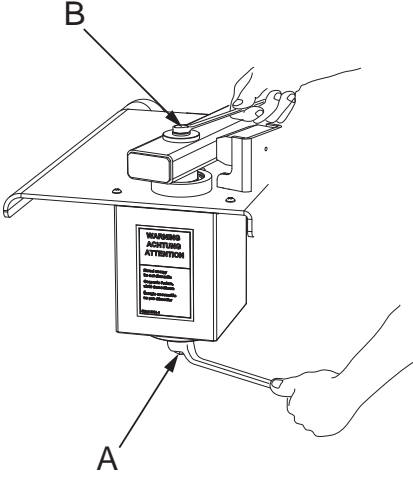

4.2.18 Adjusting tension arm unit

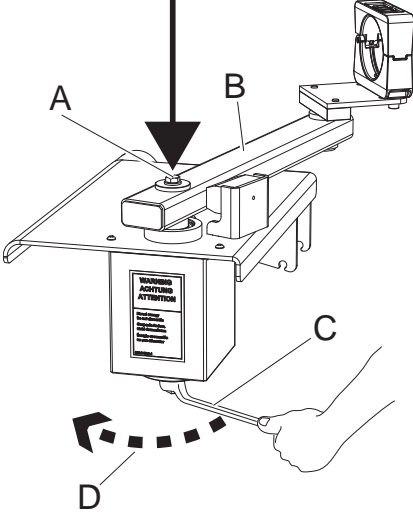
Continued

	Action	Note
3	<p> DANGER</p> <p>Loosening the spring bolt in the coming steps will release the spring tension. Two persons are required to perform the procedure in a safe manner.</p>	
4	<p>Person 1: Take a grip of the spring bolt with a 27 mm wrench (extended shaft) and be prepared to hold against the spring force.</p> <p>Person 2: Loosen the <i>upper screw</i> (M12), with a 18 mm standard wrench approximately 10-15 mm.</p> <p> Note</p> <p>The spring force will probably not be released until when the upper screw is tapped down in the next step, but it is a good idea to be prepared to hold against the force already in this step.</p>	 <p>xx1700002243</p> <p>A Spring bolt B Upper screw M12</p>
5	<p>Person 1: Keep holding the 27 mm wrench in a firm position as the spring force now will be released.</p> <p>Person 2: Release the tension in the spring bolt by tapping the <i>upper screw</i> with a rubber mallet until the tension is released (when bolt goes down).</p> <p> DANGER</p> <p>Hold the wrench in a firm position as the spring force now will try to rotate the wrench to the left.</p>	 <p>xx0500001504</p> <p>A Upper screw M12 B Tension arm C Standard wrench 27 mm with extended shaft (extension not shown in figure) D Direction in which the spring force will rotate the wrench</p>

Continues on next page

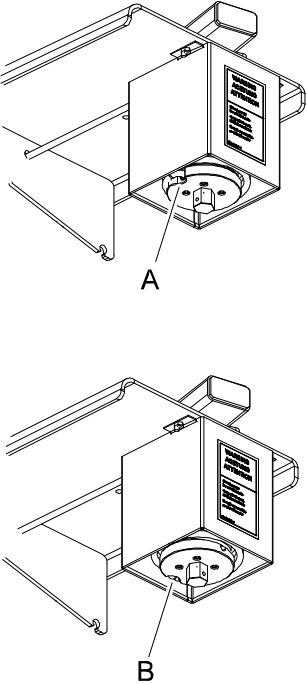
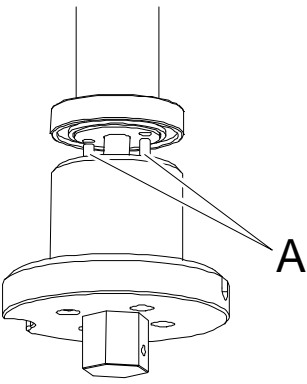
Adjusting the spring force and securing the spring

	Action	Note
1	<p>Use the wrench to adjust appropriate spring force. Carefully lower the spring if needed.</p> <p>To <i>increase</i> the force: pull the wrench backward.</p> <p>To <i>decrease</i> the force: push the wrench forward.</p>	 <p>xx0500001562</p> <p>View: A Showing the spring with no tension B Showing the spring with $\frac{3}{4}$ tension (270°).</p>
2	<p>Secure the spring force by lifting up the spring and fit into hole circle.</p> <p>The spring could be set in steps of $\frac{1}{8}$ of a turn.</p>	<p>View of inside.</p>  <p>xx0500001509</p> <p>A Guide pins</p>
3	 <p>Tip</p> <p>The next step is best performed by two persons working together.</p>	

Continues on next page

4 Repair

4.2.18 Adjusting tension arm unit

Continued

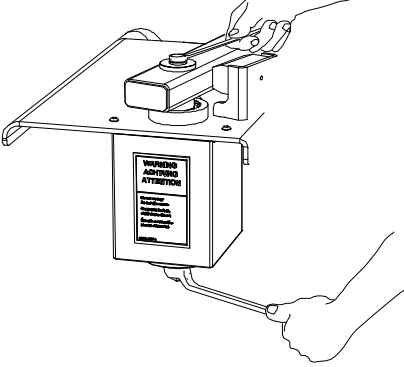
	Action	Note
4	<p>Person 1: Hold the spring bolt in a firm position.</p> <p>Person 2: Fasten the spring by tightening the upper screw (M12).</p>	 <p>xx0500001507</p>

4.3 DressPack cable package, general

4.3.1 Replacement of hose reinforcement

Overview

All work detailed below is to be performed on a workbench!

How to remove the DressPack upper arm harness from the robot is detailed in section [Replacing the cable packages IRBDP MH2 UE and IRBDP SW2 UE on page 244](#) or [Replacing the cable package IRBDP SW5 CE \(DressPack Basic\) on page 257](#).

Location of hose reinforcement

The hose reinforcement is located as shown in the figure below.

Figure shows IRB 6600.

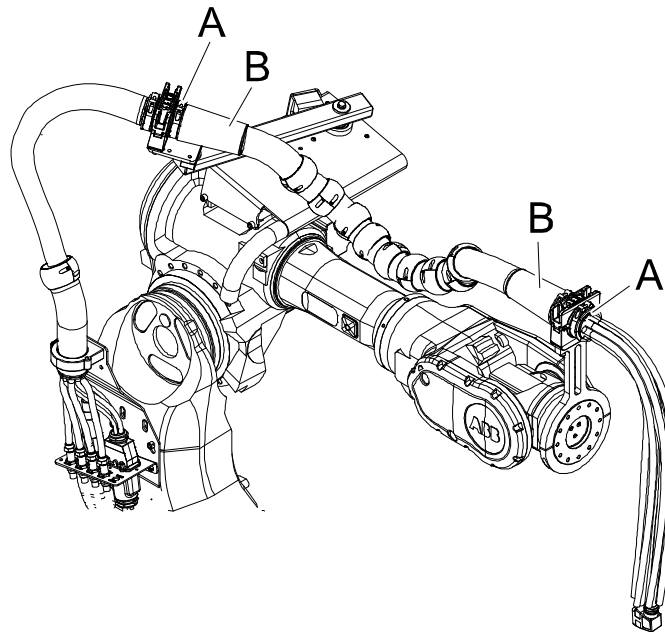

xx0500001533

A	Slide sleeves
B	Hose reinforcement

Continues on next page

4 Repair

4.3.1 Replacement of hose reinforcement

Continued

IRBDP SW 5 CE

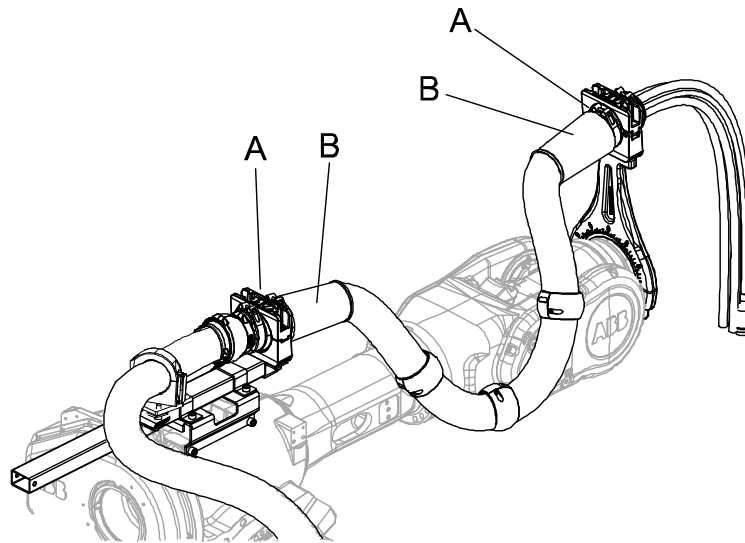

xx080000089

A	Slide sleeves
B	Hose reinforcement

Required equipment

Equipment, etc.	Spare part no.	Art. no.	Note
Hose reinforcement	3HAC022194-001		
Standard Toolkit, DressPack		3HAC17290-7	The contents are defined in section Toolkits, DressPack on page 357 .
Other tools and procedures may be required. See references to these procedures in the step-by-step instructions below.		-	These procedures include references to the tools required.

Continues on next page

Removal

The procedure below details how to remove the hose reinforcement.

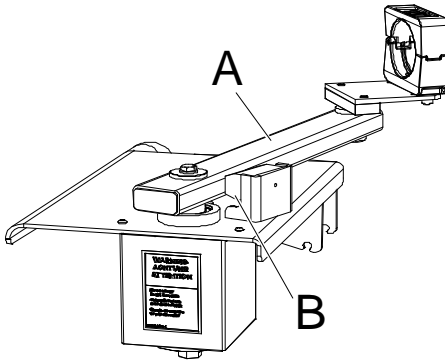
	Action	Note
1	<p>(Not applicable to cable package IRBDP SW5 CE.)</p> <p> WARNING</p> <p>The tension arm unit pulls the hose package backwards! Hence, in order to avoid accidents, the robot must be positioned in a way that the arm of the tension arm unit is placed in its rear position.</p> <p>The <i>tension arm</i> must rest on the <i>damper</i> before the disassembly of the upper arm starts!</p>	 <p>xx0500001794</p> <p>Parts:</p> <ul style="list-style-type: none"> • A: Tension arm • B: Damper
2	<p>Perform the procedure for replacement and the first steps of the procedure for repair of the cable package.</p> <p>This will give access to the slide sleeves.</p>	<p>Detailed in section Replacing the cable packages IRBDP MH2 UE and IRBDP SW2 UE on page 244</p> <p>Detailed in section Replacing the cable package IRBDP SW5 CE (DressPack Basic) on page 257.</p> <p>Detailed in section Repair of process cable package on page 316.</p>
3	<p>Pull the hose reinforcements off the protective hose.</p>	<p>Make sure that the protective hose is not damaged.</p> <p>If the protective hose is damaged, replace it!</p>

Refitting

The procedure below details how to refit the hose reinforcement.

	Action	Note
1	<p>Select the hose reinforcement.</p>	<p>Article number is specified in the chapter Spare parts on page 361.</p>
2	<p>Gently push the hose reinforcement on to the protective hose.</p>	<p>Make sure the hose reinforcement rib align with the slide sleeve on assembly.</p>
3	<p>Perform the last steps of the procedure for repair of the process cable package.</p> <p>The refit the cable package on the robot.</p>	<p>Detailed in section Repair of process cable package on page 316.</p> <p>Detailed in section Fitting the cable packages IRBDP MH2 UE and IRBDP SW2 UE on page 88</p> <p>Detailed in section Replacing the cable package IRBDP SW5 CE (DressPack Basic) on page 257.</p>

4 Repair

4.3.2 Replacement of slide sleeves

4.3.2 Replacement of slide sleeves



Note

This section is not applicable to cable package IRBDP MH 3 UE, IRBDP MH3 UI, IRBDP SW6, IRBDP MH6.

Location of slide sleeves

The slide sleeves are located as shown in the figure below.

Replacement of slide sleeves is possible to be performed without removing the DressPack from the robot. However replacement may also be performed on a work bench. How to remove the DressPack from the robot is detailed in section [Replacing the cable packages IRBDP MH2 UE and IRBDP SW2 UE on page 244](#) or [Replacing the cable package IRBDP SW5 CE \(DressPack Basic\) on page 257](#).

Figure shows IRB 6600.

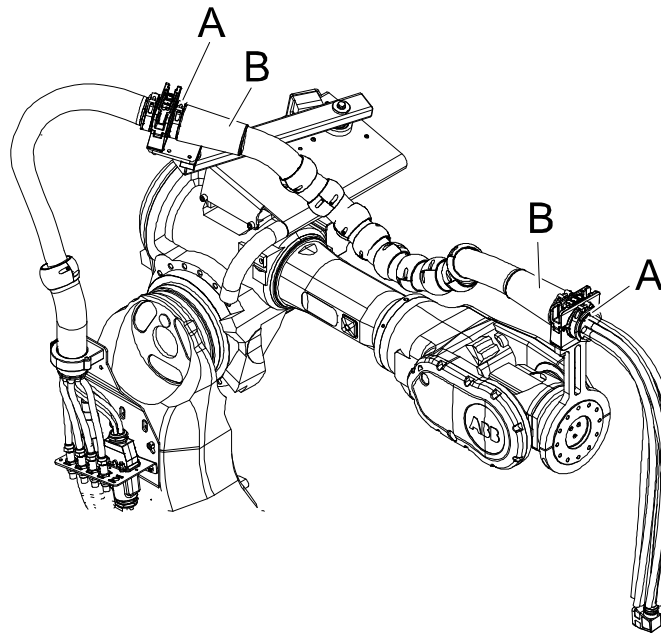

xx0500001533

A	Slide sleeves
B	Hose reinforcement

Continues on next page

IRBDP SW 5 CE

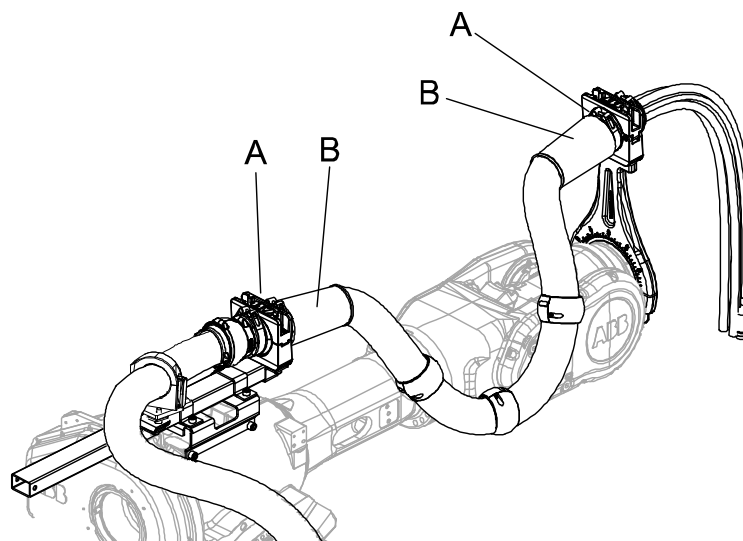

xx080000089

A	Slide sleeves
B	Hose reinforcement

Required equipment

Equipment, etc.	Art. no.	Note
Slide sleeves	3HAC16208-1	
Standard Toolkit, DressPack	3HAC17290-7	The contents are defined in section Toolkits, DressPack on page 357 .
Other tools and procedures may be required. See references to these procedures in the step-by-step instructions below.	-	These procedures include references to the tools required.

Removal

The procedure below details how to remove the slide sleeves.



	Action	Note
1	Move the robot to a position where the upper arm is pointing slightly upwards and the tension arm unit is resting against the damper.	

Continues on next page

4 Repair

4.3.2 Replacement of slide sleeves

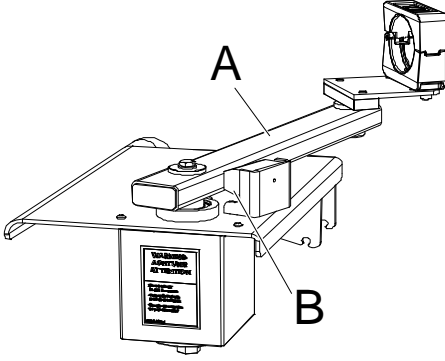
Continued

	Action	Note
2	<p>(Not applicable to cable package IRBDP SW5 CE.)</p> <p> WARNING</p> <p>The tension arm unit pulls the hose package backwards! Hence, in order to avoid accidents, the robot must be positioned in a way that the arm of the tension arm unit is placed in its rear position.</p> <p>The <i>tension arm</i> must rest on the <i>damper</i> before the disassembly of the upper arm starts!</p>	 <p>xx0500001794</p> <p>Parts:</p> <ul style="list-style-type: none"> • A: Tension arm • B: Damper
3	<p> DANGER</p> <p>Turn off all:</p> <ul style="list-style-type: none"> • electric power supply • hydraulic pressure supply • air pressure supply <p>to the robot, before entering the robot working area.</p>	
4	<p> CAUTION</p> <p>The cable package is sensitive to mechanical damage. They must be handled with care, especially the connectors, in order to avoid damaging them.</p>	
5	<p>Mark the positions of the rubber grommets on cables and hoses with reinforced tape.</p>	
6	<p>Disconnect all hose and cable connectors.</p>	<p>This is only needed if the work is going to be done on a workbench.</p>
7	<p>Open ball joint housings.</p>	
8	<p>Remove the process cable from the ball joint housings.</p>	

Continues on next page

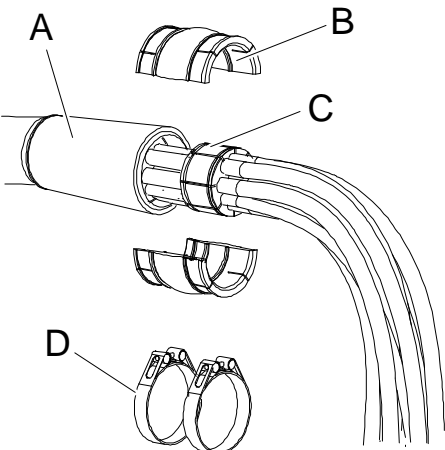
	Action	Note
9	Open the <i>hose clamps</i> .	 <p>xx0500001795</p> <p>Parts:</p> <ul style="list-style-type: none"> • A: Hose reinforcement • B: Slide sleeve • C: Rubber grommet • D: Hose clamp
10	Remove and replace the slide sleeves, one at a time.	

Refitting

The procedure below details how to refit the slide sleeves.

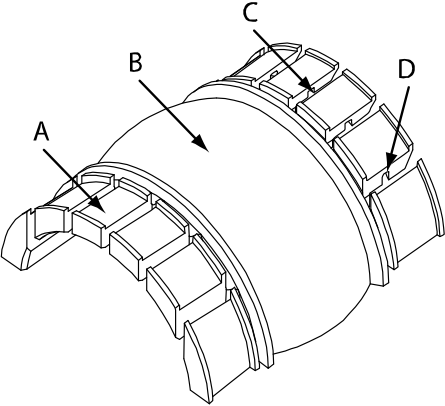
	Action	Note
1	Refit the slide sleeves over the hose reinforcement. Make sure the slide sleeves are turned the right way.	 <p>xx0300000249</p> <p>Parts:</p> <ul style="list-style-type: none"> • A: Hose clamp surface, farthest from the protective hose • B: Slide sleeve slide surface, slightly concave • C: Hose clamp surface, closest to the protective hose • D: Groove for locking the hose reinforcement

Continues on next page

4 Repair

4.3.2 Replacement of slide sleeves

Continued

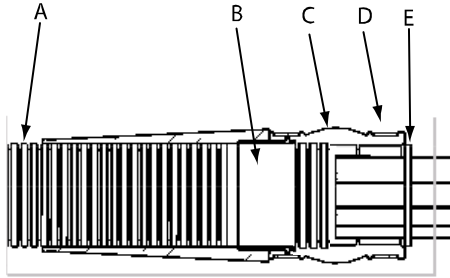
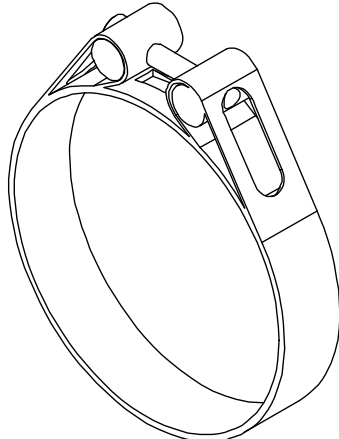
	Action	Note
2	<p>The figure to the right, shows the fitting positions of the <i>slide sleeves</i> on the <i>cable/hose retainer</i>.</p>	<p>The figure shows a cross section of the slide sleeves:</p>  <p>xx0400001007</p> <p>Parts:</p> <ul style="list-style-type: none"> • A: Protective hose • B: Hose reinforcement • C: Slide sleeves • D: Hose clamp • E: Cable/Hose retainer
3	<p>Secure the slide sleeves with <i>hose clamps</i>. In applications where a large number of cables/hoses are used, aluminum cable clamps may be used, to compress the entire package.</p> <p>The slide sleeves are correctly tightened when a fully tightened aluminum cable clamp (for example on the tension arm unit) and the process cable support axis 6 allows some swivelling.</p>	<p>Make sure both clamps face the same way!</p> <p>Make sure the gaps between the slide sleeve halves are close to identical and <i>do not coincide</i> with the vertical cuts in the hose and cable retainer!</p>  <p>xx0300000250</p> <ul style="list-style-type: none"> • Hose clamp
4	<p>Check that the cables and hoses are in the right position.</p>	<p>Use the makings of the reinforced tape done earlier.</p>
5	<p>Refit the cable package in the ball joint housing.</p>	
6	<p>Reconnect cable and hose connectors.</p>	

4.4 Water and air unit

4.4.1 Replacement of Air supply circuit

Location of Water and air unit

The Water and air unit is located as shown in the figure.

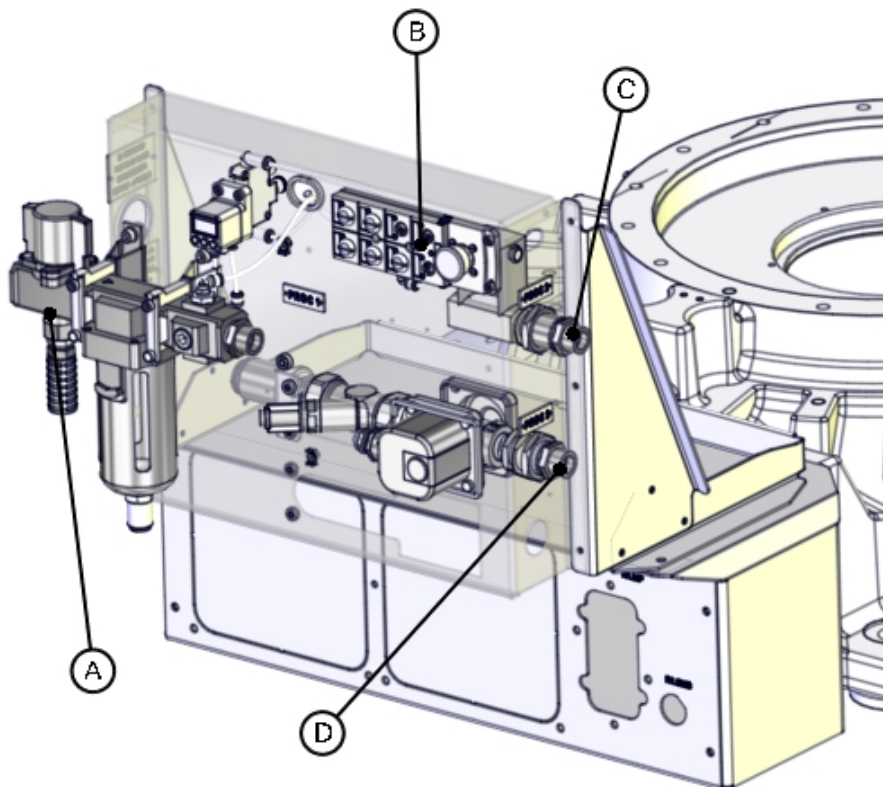

xx1300002328

A	Air supply circuit
B	Split box
C	Water in circuit
D	Water return circuit

Continues on next page

4 Repair

4.4.1 Replacement of Air supply circuit

Continued

Location of Air supply circuit, type S

The Air supply circuit is located as shown in the figure below.

There are two versions available of the Air supply circuit - *with* an Electrical Proportional Valve (EP) or *without* one.

The figure shows the Air supply circuit *without* Electrical Proportional valve.

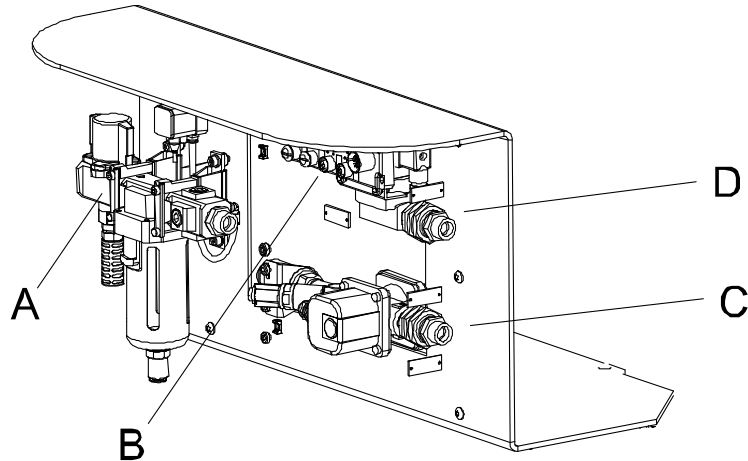

xx0600003293

A	Air supply circuit
B	Split box
C	Water return circuit
D	Water in circuit

The figure shows the Air supply circuit *with* an Electrical Proportional valve.

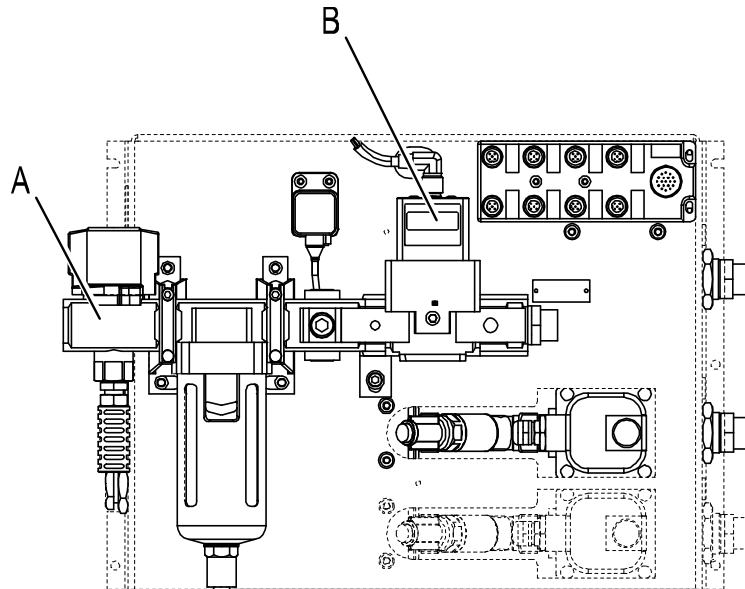

xx0600003460

A	Air supply circuit
B	Electrical Proportional Valve (EP)

Continues on next page

Location of Air supply circuit, type Sb

The Air supply circuit is located as shown in the figure below.

There are two versions available of the Air supply circuit - *with* an Electrical Proportional Valve (EP) or *without* one.

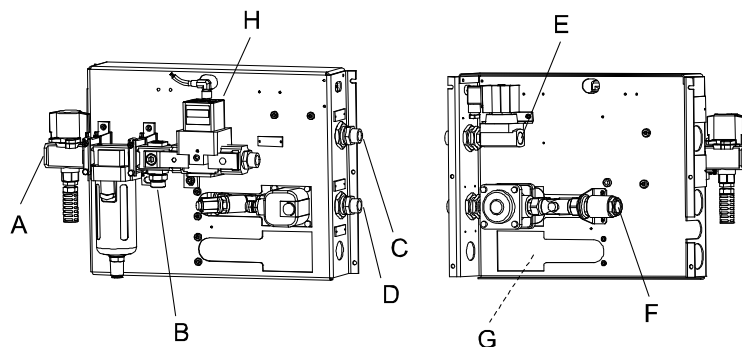

xx080000124

A	Air supply circuit
B	PROC 1 on robot base
C	PROC 2 on robot base
D	PROC 3 on robot base
E	Shop water supply
F	Shop water drain
G	PROC 4 on robot base (option)
H	Electrical Proportional Valve (EP)

Required equipment

Equipment	Art. no.	Note
Water and air unit	See <i>Spare parts</i> .	A number of versions are available. The Water and Air unit assembly contains all required hardware for fitting and connecting.
Standard toolkit, DressPack	3HAC17290-7	The contents are defined in section Toolkits, DressPack on page 357 .
Circuit diagram	3HAC026208-001	Dresspack for spotwelding

General precautions**Note**

If the water and air unit is equipped with an Electrical proportional valve, the valve retains the set pressure on the output side (temporarily), when power or incoming air is shut off.

Continues on next page



4 Repair

4.4.1 Replacement of Air supply circuit

Continued

Removal



The procedure below details how to remove the Air supply circuit. It does not deal with details specific to each version, such as article numbers, connector types etc. For details see the *Spare parts* section.

	Action	Note
1	 CAUTION The system contains compressed air. Observe the safety information in section <i>Pneumatic or hydraulic related hazards on page 28</i> .	
2	Turn off the hand operated air valve on the air supply circuit.	The air hoses on the robot will be decompressed.
3	With the option Electrical proportional valve: In addition to turning off the hand operated valve on the air supply circuit (see above), <i>the output pressure of the Electrical Proportional valve must be reduced separately</i> either by changing the reference signal to zero first and/or exhausting it with a separate valve. It is also possible to exhaust air pressure by activating attached units to consume any residual pressure.	 Note Reducing the pressure of the Electrical Proportional valve by changing the reference signal to zero, must be done <i>before</i> the air supply is turned off since the power supply to the Electrical proportional valve is turned off automatically at insufficient air pressure.
4	Turn off the shop floor air supply to the Water and Air unit.	
5	Remove the hose of the compressed air supply of the workshop.	
6	Remove the Proc 1 hose from the air supply unit.	
7	Remove the Proc 4 hose from the air supply unit.	Only if the option Proportional valve has been selected.
8	Disconnect the pressure switch tube from the Air circuit Cross interface.	
9	Disconnect the pressure switch connector on the split box, according to the circuit diagram.	
10	Disconnect the pressure switch from the mounting plate.	
11	If the option proportional valve is selected, disconnect the proportional valve connectors on the split box according to the circuit diagram.	
12	Unscrew the four attachment screws holding the air supply circuit and remove it.	

Continues on next page

Refitting

The procedure below details how to refit the air supply circuit. It does not deal with details specific to each version, such as article numbers, connector types etc. For details see the *Spare parts* section.

	Action	Note
1	Fit the air supply circuit with its four attachment screws.	
2	Connect the proportional valve connectors on the split box according to the circuit diagram.	Only if the option Proportional valve has been selected.
3	Connect the pressure switch to the mounting plate.	
4	Connect the pressure switch connector on the split box according to the circuit diagram.	
5	Connect the pressure switch tube from the Air circuit Cross interface.	
6	Connect the Proc 4 hose from the Air supply unit.  CAUTION Do not tighten the brass couplings for water and air with excessive force.	Only if the option Proportional valve has been selected. Tightening torque: <ul style="list-style-type: none"> • Brass coupling 1/2": 31 Nm. • Stainless steel coupling 1/2": 49 Nm. • Brass coupling 3/8": 17 Nm. • Mixed metals: Use the lower tightening torque value of the two metals. Always apply Molykote P1900 to stainless steel couplings and apply if needed for couplings of mixed metals or brass.
7	Connect the Proc 1 hose from the Air supply unit.  CAUTION Do not tighten the brass couplings for water and air with excessive force.	Tightening torque: <ul style="list-style-type: none"> • Brass coupling 1/2": 31 Nm. • Stainless steel coupling 1/2": 49 Nm. • Brass coupling 3/8": 17 Nm. • Mixed metals: Use the lower tightening torque value of the two metals. Always apply Molykote P1900 to stainless steel couplings and apply if needed for couplings of mixed metals or brass.
8	Connect the hose of the compressed air supply of the workshop.	
9	Turn on the air supply to the Water and Air unit.	
10	Turn on the hand operated air valve on the air supply circuit.	The hoses at the robot will be compressed.
11	See if there are any leakages.	Tighten if there is leakage.

4 Repair

4.4.2 Replacement of Water-in circuit

4.4.2 Replacement of Water-in circuit

Location of Water-in circuit, type S

The water in circuit is located on the rear side of the Water and air unit as shown in the figure.

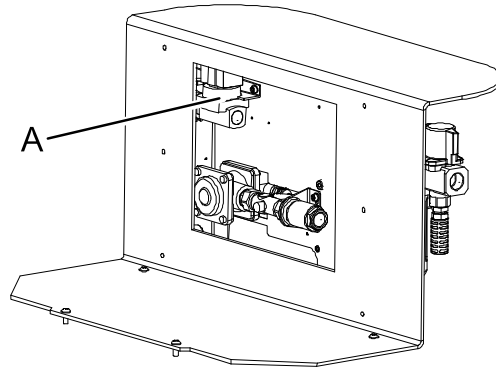

xx0600003462

A	Water-in circuit
---	------------------

Location of Water-in circuit, type Sb

The water in circuit is located on the rear side of the Water and air unit as shown in the figure.

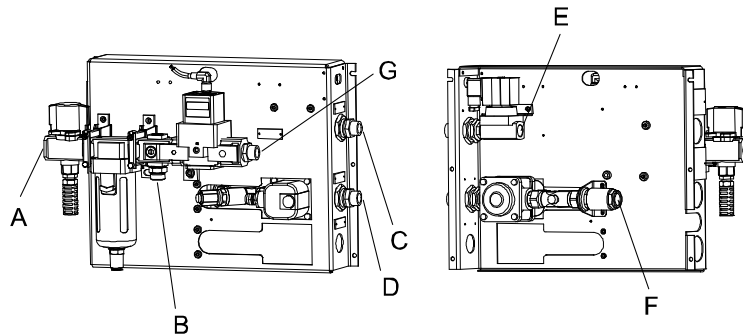

xx0800000122

A	Air supply circuit
B	PROC 1 on robot base
C	PROC 2 on robot base
D	PROC 3 on robot base
E	Water-in circuit
F	Water drain
G	PROC 4 on robot base (option)

Continues on next page

Required equipment

Equipment	Art. no.	Note
Water and Air unit	See <i>Spare parts</i> section!	A number of versions are available. The Water and Air unit assembly contains all required hardware for fitting and connecting.
Standard toolkit, DressPack	3HAC17290-7	The contents are defined in section Toolkits, DressPack on page 357 .
Circuit diagram	3HAC026208-001	Dresspack for spotwelding

Removal

The procedure below details how to remove the water-in circuit. It does not deal with details specific to each version, such as article numbers, connector types etc. For details see the *Spare parts* section.

	Action	Note
1	Turn off the water supply to the Water and Air unit.	
2	Remove the hose of the water supply of the workshop to the Water-in circuit.	
3	Remove the Proc 2 hose from the Water and Air unit.	
4	Remove the Pushlok nipple.	
5	Loosen the locking nut.	
6	Unscrew the two attachment screws holding the water-in circuit.	
7	Remove the Water-in circuit from the mounting plate.	
8	Remove the DIN-connector from the electrical water valve.	

Refitting

The procedure below details how to refit the water-in circuit. It does not deal with details specific to each version, such as article numbers, connector types etc. For details see the *Spare parts* section.

	Action	Note
1	Attach the DIN-connector to the electrical water valve.	
2	Fit the water-in circuit with its two attachment screws on the mounting plate.	
3	Tighten the locking nut.	
4	Fit the Pushlok nipple.	

Continues on next page

4 Repair

4.4.2 Replacement of Water-in circuit

Continued

	Action	Note
5	<p>Connect the Proc 2 hose on the Water and Air unit.</p> <p> CAUTION</p> <p>Do not tighten the brass couplings for water and air with excessive force.</p>	<p>Tightening torque:</p> <ul style="list-style-type: none">• Brass coupling 1/2": 31 Nm.• Stainless steel coupling 1/2": 49 Nm.• Brass coupling 3/8": 17 Nm.• Mixed metals: Use the lower tightening torque value of the two metals. <p>Always apply Molykote P1900 to stainless steel couplings and apply if needed for couplings of mixed metals or brass.</p>
6	Connect the hose of the workshop water supply to the Water-in circuit.	
7	Turn on the water supply to the Water and Air unit.	
8	Check for leakages.	Tighten if there are any leaks.

4.4.3 Replacement of Water-return circuit

Location of Water-return circuit, type S

The Water-return circuit (or circuits) is located on the rear side of the Water and air unit as shown in the figure.

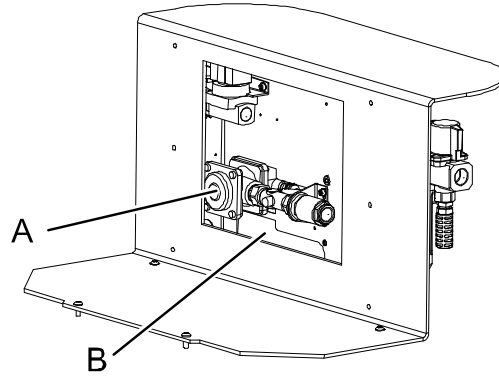

xx0600003464

A	Water-return circuit
B	Position for second Water-return circuit

Location of Water-return circuit, type Sb

The Water-return circuit (or circuits) is located on the rear side of the Water and air unit as shown in the figure.

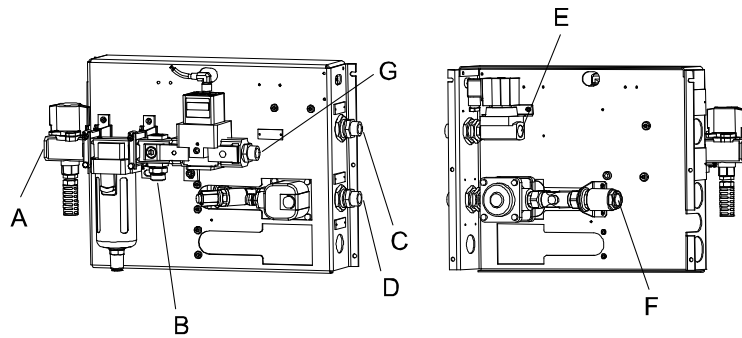

xx0800000122

A	Air supply circuit
B	PROC 1 on robot base
C	PROC 2 on robot base
D	PROC 3 on robot base
E	Water-in circuit
F	Water-return circuit
G	PROC 4 on robot base (option)

Continues on next page

4 Repair

4.4.3 Replacement of Water-return circuit

Continued

Required equipment

Equipment	Art. no	Note
Water and Air unit	See Spare Parts section.	A number of versions are available. The Water and Air unit assembly contains all required hardware for fitting and connecting.
Standard toolkit, DressPack	3HAC17290-7	The contents are defined in section Toolkits, DressPack on page 357 .
Circuit diagram	3HAC026208-001	Dresspack for spotwelding

Removal

The procedure below details how to remove the water-return circuit. It does not deal with details specific to each version, such as article numbers, connector types etc. For details see *Spare parts* section.



	Action	Note
1	Turn off the water supply to the Water and Air unit.	
2	Turn off the shop water drain from the Water and Air unit.	
3	Remove the hose of the shop floor water drain from the Water-return circuit.	One water-return: <ul style="list-style-type: none">• Disconnect the hose from the check valve Second water-return: <ul style="list-style-type: none">• Disconnect the hose from the bulkhead connector.
4	Loosen the locking nut.	Only if the option <i>Second water return</i> has been selected.
5	Remove the Proc 3 hose from the Water and Air unit.	
6	Remove the Proc 4 hose from the Water and Air unit.	Only if the option <i>Second water return</i> has been selected.
7	Remove the Pushlok nipple (or nipples) for return water.	
8	Loosen and remove the locking nut (or nuts).	
9	Unscrew the two attachment screws securing the mounting bracket (or brackets).	
10	Remove the Water-return circuit (or circuits) from the mounting plate.	

Refitting

The procedure below details how to refit the water-return circuit. It does not deal with details specific to each version, such as article numbers, connector types etc. For details see *Spare parts* section.

	Action	Note
1	Place the Water-return circuit (or circuits) on the mounting plate.	
2	Fit the two attachment screws securing the mounting bracket (or brackets).	

Continues on next page

	Action	Note
3	Fit and tighten the locking nut (or nuts).	
4	Fit the Pushlok nipple (or nipples).	
5	<p>Connect the Proc 3 hose from the Water and Air unit.</p> <p> CAUTION</p> <p>Do not tighten the brass couplings for water and air with excessive force.</p>	<p>Tightening torque:</p> <ul style="list-style-type: none"> • Brass coupling 1/2": 31 Nm. • Stainless steel coupling 1/2": 49 Nm. • Brass coupling 3/8": 17 Nm. • Mixed metals: Use the lower tightening torque value of the two metals. <p>Always apply Molykote P1900 to stainless steel couplings and apply if needed for couplings of mixed metals or brass.</p>
6	<p>Connect the Proc 4 hose from the Water and Air unit.</p> <p> CAUTION</p> <p>Do not tighten the brass couplings for water and air with excessive force.</p>	<p>Tightening torque:</p> <ul style="list-style-type: none"> • Brass coupling 1/2": 31 Nm. • Stainless steel coupling 1/2": 49 Nm. • Brass coupling 3/8": 17 Nm. • Mixed metals: Use the lower tightening torque value of the two metals. <p>Always apply Molykote P1900 to stainless steel couplings and apply if needed for couplings of mixed metals or brass.</p> <p>Only if the option <i>Second water return</i> has been selected.</p>
7	Tighten the locking nut, at the shop floor side.	Only if the option <i>Second water return</i> has been selected.
8	Connect the hose of the shop water drain to the water-return circuit.	
9	Turn on the water supply to the Water and Air unit.	
10	Activate the electrical valve.	
11	First turn on and then turn off the shop water drain.	This is done in order to evacuate all air in the circuit.
12	Wait a couple of minutes and check for leakage.	Tighten if there is any leakage.
13	Turn on the shop water drain.	

4 Repair

4.4.4 Replacement of Air filter element

4.4.4 Replacement of Air filter element

Replacement of air filter

Type S

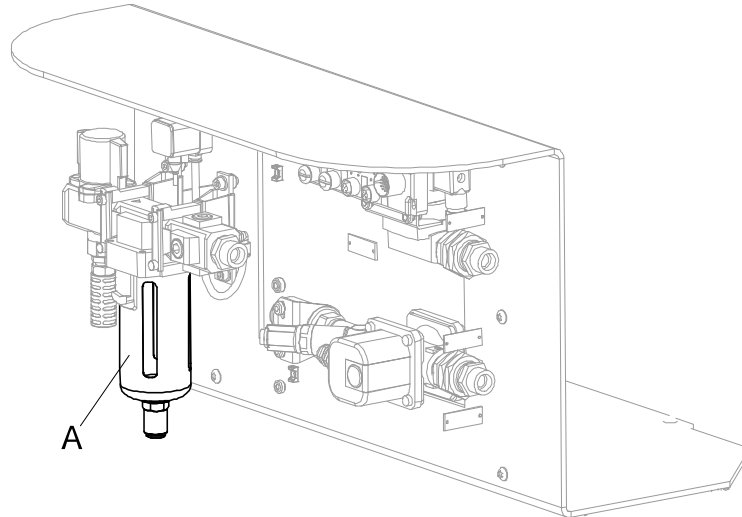

xx0700000400

A	Air filter
---	------------

Type Sb

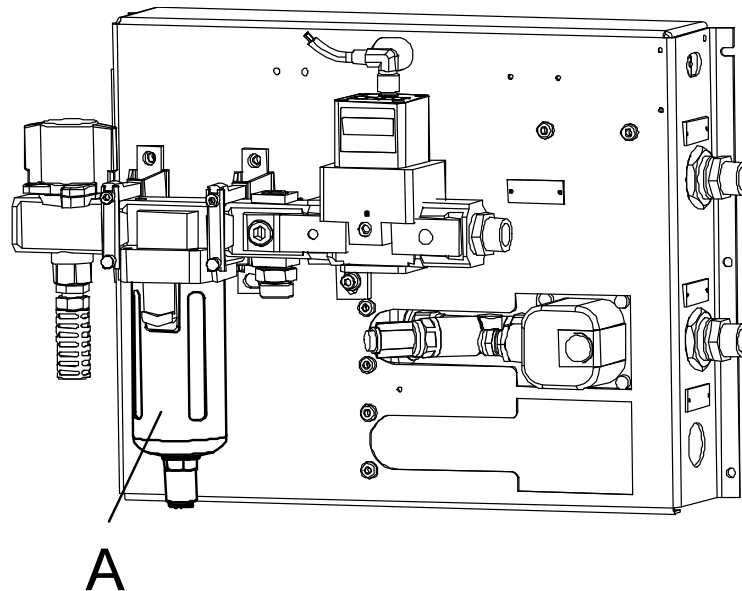

xx0800000125

A	Air filter
---	------------

Continues on next page

The procedure below details how to replace the air filter element on the Water and Air unit.

	Action	Note
1	Turn off the hand operated air valve and make sure that the air filter is not pressurized.	
2	Remove the bowl assembly, by following these steps: <ul style="list-style-type: none"> • Push the bowl assembly lock button. • Lift the bowl assembly. • Rotate the bowl assembly 45° (right or left). • Pull out the assembly. 	
3	Remove the baffle, filter element and deflector by rotating the baffle counterclockwise by hand.	
4	Fit the deflector to the body assembly. Mind the fitting direction of the deflector (concave in which the element goes into).	Deflector direction: Concave, facing the filter element.
5	Fit the new filter element by inserting it to the deflector concave.	
6	Fit the baffle by inserting it to the filter element. Mind the fitting direction of the baffle (convex to which the element goes).	Baffle direction: Convex, facing the filter element.
7	Tighten the baffle to settle the baffle, filter element and deflector by rotating the baffle counterclockwise until it contacts the element and deflector lightly. Rotate approximately one half revolution counterclockwise further in order to tighten them.	Tightening torque: 0.9 Nm
8	Fit the bowl assembly. Match the mating mark of the body and the bowl assembly to insert the assembly to the body. Rotate the assembly 45° (right or left) until the lock button is tossed up to fit the bowl assembly.	 Note Check that the lock button has tossed up!

This page is intentionally left blank

5 Decommissioning

5.1 Environmental information

Introduction

ABB robots contain components in different materials. During decommissioning, all materials should be dismantled, recycled, or reused responsibly, according to the relevant laws and industrial standards. Robots or parts that can be reused or upcycled helps to reduce the usage of natural resources.

Symbol

The following symbol indicates that the product must not be disposed of as common garbage. Handle each product according to local regulations for the respective content (see table below).

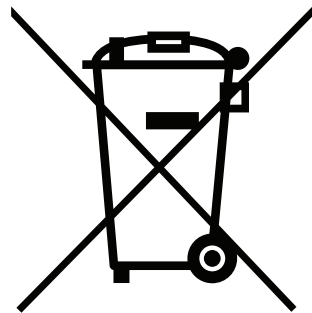

xx180000058

Materials used in the product

The table specifies some of the materials in the product and their respective use throughout the product.

Dispose components properly according to local regulations to prevent health or environmental hazards.

Material	Example application
Aluminium	Covers, synchronization brackets
Batteries, Lithium	Serial measurement board
Cast iron/nodular iron	Base, lower arm, upper arm
Copper	Cables, motors
Neodymium	Brakes, motors
Nickel	Turning disc (foundry)
Plastic/rubber	Cables, connectors, drive belts, and so on.
Steel	Gears, screws, base frame, and so on.

Continues on next page

5 Decommissioning

5.1 Environmental information

Continued

Oil and grease

Where possible, arrange for oil and grease to be recycled. Dispose of via an authorized person/contractor in accordance with local regulations. Do not dispose of oil and grease near lakes, ponds, ditches, down drains, or onto soil. Incineration must be carried out under controlled conditions in accordance with local regulations.

Also note that:

- Spills can form a film on water surfaces causing damage to organisms. Oxygen transfer could also be impaired.
- Spillage can penetrate the soil causing ground water contamination.

6 Reference information

6.1 Introduction

General

This chapter includes general information, complementing the more specific information in the different procedures in the manual.

6 Reference information

6.2 Unit conversion

6.2 Unit conversion

Converter table

Use the following table to convert units used in this manual.

Quantity	Units		
Length	1 m	3.28 ft.	39.37 in
Weight	1 kg	2.21 lb.	
Weight	1 g	0.035 ounces	
Pressure	1 bar	100 kPa	14.5 psi
Force	1 N	0.225 lbf	
Moment	1 Nm	0.738 lbf-ft	
Volume	1 L	0.264 US gal	

6.3 Screw joints

General

This section describes how to tighten the various types of screw joints on ABB robots.

The instructions and torque values are valid for screw joints comprised of metallic materials and do *not* apply to soft or brittle materials.

UNBRAKO screws

UNBRAKO is a special type of screw recommended by ABB for certain screw joints. It features special surface treatment (Gleitmo as described below) and is extremely resistant to fatigue.

Whenever used, this is specified in the instructions, and in such cases, *no other type of replacement screw* is allowed. Using other types of screws will void any warranty and may potentially cause serious damage or injury.

Gleitmo treated screws

Gleitmo is a special surface treatment to reduce the friction when tightening the screw joint. It is recommended by ABB for M6-M20 screw joints. Screws treated with Gleitmo may be reused 3-4 times before the coating disappears. After this the screw must be discarded and replaced with a new one.

When handling screws treated with Gleitmo, protective gloves of nitrile rubber type should be used.

Generally, screws are lubricated with *Gleitmo 603* mixed with *Geomet 500* or *Geomet 702* in proportion 1:3. *Geomet* thickness varies according to screw dimensions, refer to the following.

Dimension	Lubricant	Geomet thickness
M6-M20 (any length except M20x60)	<i>Gleitmo 603 + Geomet 500</i>	3-5 µm
M6-M20 (any length except M20x60)	<i>Gleitmo 603 + Geomet 720</i>	3-5 µm
M20x60	<i>Gleitmo 603 + Geomet 500</i>	8-12 µm
M20x60	<i>Gleitmo 603 + Geomet 720</i>	6-10 µm

Screws lubricated in other ways

Screws lubricated with Molykote 1000 or Molykote P1900 should *only* be used when specified in the repair, maintenance or installation procedure descriptions.

In such cases, proceed as follows:

- 1 Apply lubricant to the screw thread.
- 2 Apply lubricant between the plain washer and screw head.
- 3 Screw dimensions of M8 or larger must be tightened with a torque wrench. Screw dimensions of M6 or smaller may be tightened without a torque wrench *if* this is done by trained and qualified personnel.

Continues on next page

6 Reference information

6.3 Screw joints

Continued

Lubricant	Article number
Molykote 1000 (molybdenum disulphide grease)	3HAC042472-001
Molykote P1900 (molybdenum disulphide grease)	3HAC070875-001

Tightening torque

Before tightening any screw, note the following:

- Determine whether a **standard** tightening torque or **special** torque is to be applied. The **standard torques** are specified in the following tables. Any **special torques** are specified in the repair, maintenance or installation procedure descriptions. **Any special torque specified overrides the standard torque!**
- Use the *correct tightening torque* for each type of screw joint.
- Only use *correctly calibrated* torque keys.
- *Always tighten the joint by hand*, and never use pneumatic tools.
- Use the *correct tightening technique*, that is *do not* jerk. Tighten the screw in a slow, flowing motion.
- Maximum allowed total deviation from the specified value is **10%!**

Tightening torque for oil-lubricated screws with slotted or cross-recess head screws

The following table specifies the recommended standard tightening torque for *oil-lubricated screws with slotted or cross-recess head screws*.



Note

A special torque specified in the repair, maintenance or installation procedure overrides the standard torque.

Tightening torque for oil-lubricated screws with allen head screws

The following table specifies the recommended standard tightening torque for *oil-lubricated screws with allen head screws*.



Note

A special torque specified in the repair, maintenance or installation procedure overrides the standard torque.

Dimension	Tightening torque (Nm)	Tightening torque (Nm)	Tightening torque (Nm)
	Class 8.8, oil-lubricated	Class 10.9, oil-lubricated	Class 12.9, oil-lubricated
M5	6	-	-
M6	10	-	-
M8	24	34	40
M10	47	67	80
M12	82	115	140
M16	200	290	340
M20	400	560	670

Continues on next page

Dimension	Tightening torque (Nm) Class 8.8, oil-lubricated	Tightening torque (Nm) Class 10.9, oil-lubricated	Tightening torque (Nm) Class 12.9, oil-lubricated
M24	680	960	1150

Tightening torque for lubricated screws (Molykote, Gleitmo or equivalent) with allen head screws
The following table specifies the recommended standard tightening torque for *screws lubricated with Molykote 1000, Gleitmo 603 or equivalent with allen head screws.*

**Note**

A special torque specified in the repair, maintenance or installation procedure overrides the standard torque.

Dimension	Tightening torque (Nm) Class 10.9, lubricated ⁱ	Tightening torque (Nm) Class 12.9, lubricated ⁱ
M5		8
M6		14
M8	28	35
M10	55	70
M12	96	120
M16	235	300
M20	460	550
M24	790	950

ⁱ Lubricated with Molykote 1000, Gleitmo 603 or equivalent

Water and air connectors

The following table specifies the recommended standard tightening torque for *water and air connectors.*

**Note**

A special torque specified in the repair, maintenance or installation procedure overrides the standard torque.

Dimension	Material	Tightening torque Nm - Nominal	Tightening torque Nm - Min.	Tightening torque Nm - Max.
ALL	Mixed	The lower tightening torque of the two materials.		
1/8	Brass only	12	8	15
1/4	Brass only	15	10	20
3/8	Brass only	20	15	25
1/2	Brass only	40	30	50
1/2	Stainless steel only	49	47	59
3/4	Brass only	70	55	90

6 Reference information

6.4 Weight specifications

6.4 Weight specifications

Definition

In installation, repair, and maintenance procedures, weights of the components handled are sometimes specified. All components exceeding 22 kg (50 lbs) are highlighted in this way.

To avoid injury, ABB recommends the use of a lifting accessory when handling components with a weight exceeding 22 kg. A wide range of lifting accessories and devices are available for each manipulator model.

Example

Following is an example of a weight specification in a procedure:

	Action	Note
	 CAUTION The arm weighs 25 kg. All lifting accessories used must be sized accordingly.	

6.5 Toolkits, DressPack

General

All service (repair, maintenance and installation) instructions contain lists of tools required to perform the specified activity. All special tools, that is all tools that are not considered standard as defined below, are listed in their instructions respectively.

This way, the tools required are the sum of the Standard Toolkit and any tools listed in the instruction.

Standard toolkit

This standard toolkit contains a set of standard tools used for DressPack, 3HAC17290-7.

Qty	Article number	Tool	Note
1	-	Socket head cap, 5-17mm	-
1	-	Torx socket no: 20-60	-
1	-	Phillips screwdriver, small	For Harting connectors
1	-	Flat screwdriver, medium	For Harting connectors
2	-	Ring-open-end spanner 8-19 mm	For water connectors on water and air unit
1	-	Open end wrench, 27 mm.	For Tension arm unit and water connectors on DressPack
1	-	Open end wrench, 36 mm	For water connectors on DressPack

Toolkit, water panel

This toolkit contains tools needed for water panel:

Qty	Article number	Tool	Note
1	-	Socket head cap 4 mm	For water panel
2	-	Ring-open-end spanner, 36 mm	For water panel

Toolkit, cables

This toolkit contains tools needed for work with cables:



Qty	Article number	Tool	Note
1	0999 000 0171 (D-sub)	Removal and Insertion tool for pins and sockets	Art. no. from Harting
1	0999 000 0012 (HAN DD)	Removal tool for pins and sockets	Art. no. from Harting
1	0999 000 0319 (HAN EE)	Removal tool for pins and sockets	Art. no. from Harting
1	0999 000 0059 (HAN DD and HAN EE)	Insertion tool for pins and sockets	Art. no. from Harting
1	-	Stripping pliers	

Continues on next page

6 Reference information

6.5 Toolkits, DressPack

Continued

Qty	Article number	Tool	Note
1	09 99 000 0021	Crimping tool HARTING with locator	Art. no. from Harting
1	09 99 000 0001	Crimping tool BUCHANAN, HARTING	Art. no. from Harting
1	09 99 000 0175 09 99 000 0169	Crimping tool HARTING	Art. no. from Harting
1	09 99 000 0646 (article number at Harting Technology Group)	M12 dynamometric screwdriver SW15 Torque tool for Ethernet connectors  xx2200001261	Art. no. from Harting
1	M12 torque screwdriver and M12 assembly tool (bit)	TSD 04 SAC (article number at Phoenix Contact) SAC BIT M12-D15 (article number at Phoenix Contact)  xx2200001262	Order both parts and assemble. The screwdriver has a preset torque of 0.4 Nm. Used to tighten M12 Ethernet connectors.

6.6 Lifting accessories and lifting instructions

General

Many repair and maintenance activities require different pieces of lifting accessories, which are specified in each procedure.

The use of each piece of lifting accessories is *not* detailed in the activity procedure, but in the instruction delivered with each piece of lifting accessories.

The instructions delivered with the lifting accessories should be stored for later reference.

This page is intentionally left blank

7 Spare parts

7.1 Introduction

General

This chapter contains more specific article information. It is to be regarded as a complement to the slightly generic procedure information found in the Installation, Maintenance and Repair chapters.

The robot system itself, consisting of robot and controller cabinet, is described in its own technical documents.

7 Spare parts

7.2.1 DressPack for lower arm SW - IRBDP SW2 LE

7.2 DressPack cable packages

7.2.1 DressPack for lower arm SW - IRBDP SW2 LE

General

This section describes the spare parts for DressPack lower arm cable package for Spot welding.

Lower arm cable package

Qty	Parts	Article number	Note
1	Process Cable Package lower arm SW, CPS, 4 hoses	3HAC022478-001	Paracom
1	Process Cable Package lower arm SW, CPS+SP/Ethernet, 4 hoses	3HAC034334-001	Paracom Ethernet
1	Process Cable Package lower arm SW, CPS+SP, 4 hoses	3HAC022479-001	Paracom Servo Gun
1	Process Cable Package lower arm SW, CPS+SP/Ethernet, 4 hoses	3HAC034335-001	Paracom + Ethernet Servo Gun
1	Process Cable Package lower arm SW, CPS/CBUS, 4 hoses	3HAC022480-001	Parabuscom
1	Process Cable Package lower arm SW, CPS/CBUS+SP, 4 hoses	3HAC022481-001	Parabuscom Servo Gun
1	Material Set Lower arm	3HAC022483-001	

Spare parts for cable package

Qty	Spare part	Article number	Note
0.87m	Protection hose	3HAC5320-2	Only available per whole meters
1	End jaw	3HAC14512-1	
1	Clamp jaw	3HAC14590-1	
1	Hose and cable retainer	3HAC14811-12	
1	Hose clamp diam= 79-87	3HAC5325-3	
2	Gripping clamp	3HAC14280-1	
1	Velcro strap	3HAC12625-1	
2	Strap (balancing device)	3HAC024008-001	

7.2.2 DressPack for lower arm MH - IRBDP MH1 LI

General

The following section details spare parts for DressPack lower arm internal cable package.

Lower arm Internal cable package

Qty	Parts	Article number	Note
1	Process Cable Package 1-3 MH, CPS, 1 hose	3HAC022997-001	IRB 6650S-200/3.0 IRB 6650S-190/3.0 LID IRB 6650S-125/3.5 IRB 6650S-100/3.5 LID Paracom
1	Process Cable Package 1-3 MH, CPS/Ethernet, 1 hose	3HAC034139-001	IRB 6650S-200/3.0 IRB 6650S-190/3.0 LID IRB 6650S-125/3.5 IRB 6650S-100/3.5 LID Paracom + Ethernet
1	Process Cable Package 1-3 MH, CPS/CBUS, 1 hose	3HAC022999-001	IRB 6650S-200/3.0 IRB 6650S-190/3.0 LID IRB 6650S-125/3.5 IRB 6650S-100/3.5 LID Parabuscom
1	Material set Internal MH	3HAC023054-001	Connection axis 3 IRB 6650S-200/3.0 IRB 6650S-190/3.0 LID IRB 6650S-125/3.5 IRB 6650S-100/3.5 LID
1	Material set Internal MH	3HAC022483-002	Connection axis 2 IRB 6650S-200/3.0 IRB 6650S-190/3.0 LID IRB 6650S-125/3.5 IRB 6650S-100/3.5 LID
1	Material set Internal MH	3HAC022365-001	IRB 6650S-200/3.0 IRB 6650S-190/3.0 LID IRB 6650S-125/3.5 IRB 6650S-100/3.5 LID

Spare parts for cable package

Qty	Parts	Article number	Note
1	Strap, velcro	3HAC12625-1	
1	Strap	3HAC024008-001	

7 Spare parts

7.2.3 DressPack for upper arm SW - IRBDP SW2 UE

7.2.3 DressPack for upper arm SW - IRBDP SW2 UE

General

The following section details spare parts for DressPack upper arm cable package for spot welding.

Wear parts

Some parts are more exposed to wear. These parts are listed as wear parts in the parts list, and are shown in the illustration below.

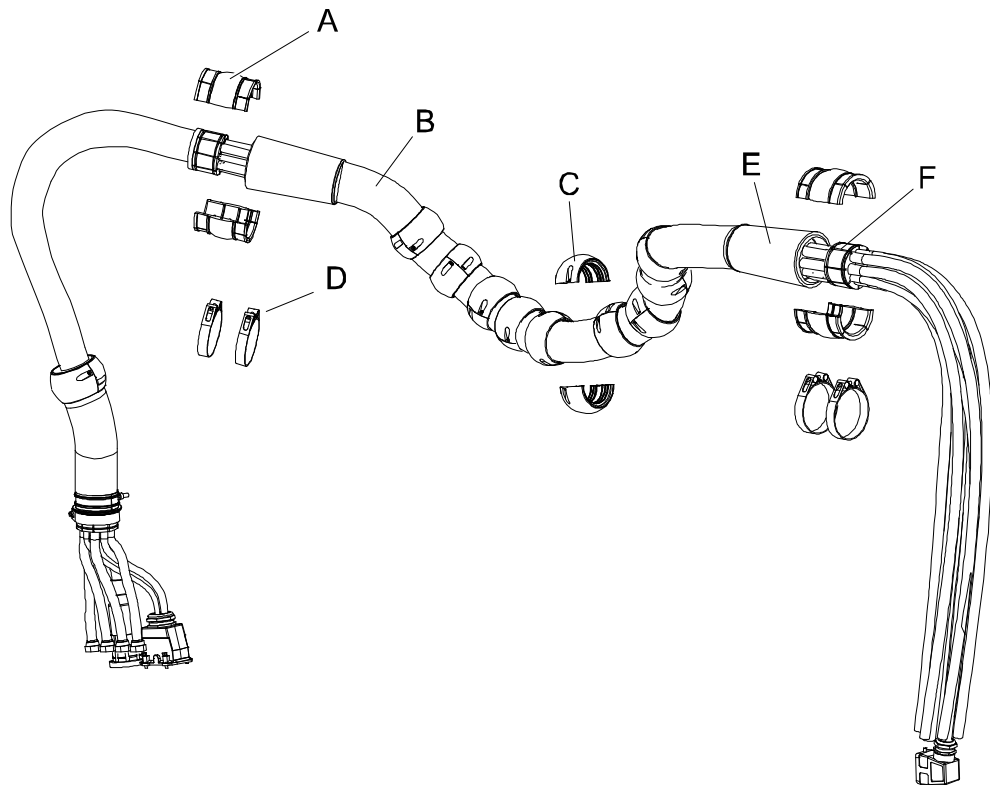

xx0500001549

A	Sliding sleeve
B	Protective hose
C	Protective sleeve
D	Hose clamp
E	Hose reinforcement
F	Hose and cable retainer
G	Cable star
H	Clamp jaw

Continues on next page

Spare Parts, Process Cable Upper arm SW 2

Qty	Parts	Article number	Note
1	Process Cable Package Upper arm SW, CPS/Ethernet, 4 hoses	3HAC023170-001	IRB 6650S-200/3.0 IRB 6650S-190/3.0 LID Paracom
1	Process Cable Package Upper arm SW, CPS/Ethernet, 4 hoses	3HAC038554-001	IRB 6650S-200/3.0 IRB 6650S-190/3.0 LID Paracom + Ethernet
1	Process Cable Package Upper arm SW, CPS/Ethernet, 4 hoses	3HAC023170-002	IRB 6650S-125/3.5 IRB 6650S-100/3.5 LID Paracom
1	Process Cable Package Upper arm SW, CPS/Ethernet, 4 hoses	3HAC038554-002	IRB 6650S-125/3.5 IRB 6650S-100/3.5 LID Paracom + Ethernet
1	Process Cable Package Upper arm SW, CPS+SP/Ethernet, 4 hoses	3HAC023171-001	IRB 6650S-200/3.0 IRB 6650S-190/3.0 LID Paracom Servo gun
1	Process Cable Package Upper arm SW, CPS+SP/Ethernet, 4 hoses	3HAC038555-001	IRB 6650S-200/3.0 IRB 6650S-190/3.0 LID Paracom + Ethernet Servo gun
1	Process Cable Package Upper arm SW, CPS+SP/Ethernet, 4 hoses	3HAC023171-002	IRB 6650S-125/3.5 IRB 6650S-100/3.5 LID Paracom Servo gun
1	Process Cable Package Upper arm SW, CPS+SP/Ethernet, 4 hoses	3HAC038555-002	IRB 6650S-125/3.5 IRB 6650S-100/3.5 LID Paracom + Ethernet Servo gun
1	Process Cable Package Upper arm SW, CPS/CBUS 4 hoses	3HAC023172-001	IRB 6650S-200/3.0 IRB 6650S-190/3.0 LID Parabuscom
1	Process Cable Package Upper arm SW, CPS/CBUS+SP 4 hoses	3HAC023173-001	IRB 6650S-200/3.0 IRB 6650S-190/3.0 LID Parabuscom Servo gun
1	Process Cable Package Upper arm SW, CPS/CBUS 4 hoses	3HAC023172-002	IRB 6650S-125/3.5 IRB 6650S-100/3.5 LID Parabuscom
1	Process Cable Package Upper arm SW, CPS/CBUS+SP 4 hoses	3HAC023173-002	IRB 6650S-125/3.5 IRB 6650S-100/3.5 LID Parabuscom Servo gun
1	Material Set upper arm	3HAC022484-001	IRB 6650S

Continues on next page

7 Spare parts

7.2.3 DressPack for upper arm SW - IRBDP SW2 UE

Continued

Spare Parts for Cable Package

Qty	Spare part	Article number	Note
3 m	Protection hose	3HAC5320-2	Wear part
11	Protective sleeve	3HAC021580-001	Wear part
2	Hose reinforcement	3HAC022194-001	Wear part
1	Hose clamp Diam=79-87	3HAC5325-3	
4	Hose clamp Diam=94-102	3HAC5325-2	
1	Clamp jaw	3HAC14590-1	
1	Cable star	3HAC023875-001	
4	Slide sleeve	3HAC16208-1	Wear part
2	Hose and cable retainer	3HAC14811-1	
1	Velcro strap	3HAC12625-1	
1	Strap holder	3HAC024716-001	
1	Strap, velcro	3HAC024008-004	
2	Hose reinforce protection (UL, UR)	3HAC17221-1	

Spare Parts included in Material Set Upper arm IRB 6650S

Qty	Spare part	Article number	Note
1	Tension arm unit	3HAC022307-001	
1	Damper, tension arm	3HAC022307-048	Wear part
1	Process cable support axis 6, complete	3HAC025495-003	
1	Ball joint housing	3HAC021601-001	
1	Gripping clamp	3HAC14280-1	Wear part

7.2.4 DressPack for Upper arm MH - IRBDP MH2 UE

General

The following section details spare parts for DressPack upper arm cable package MH.

Wear parts

Some parts are more exposed to wear. These parts are marked as wear parts in the parts list, and are shown in the illustration below.

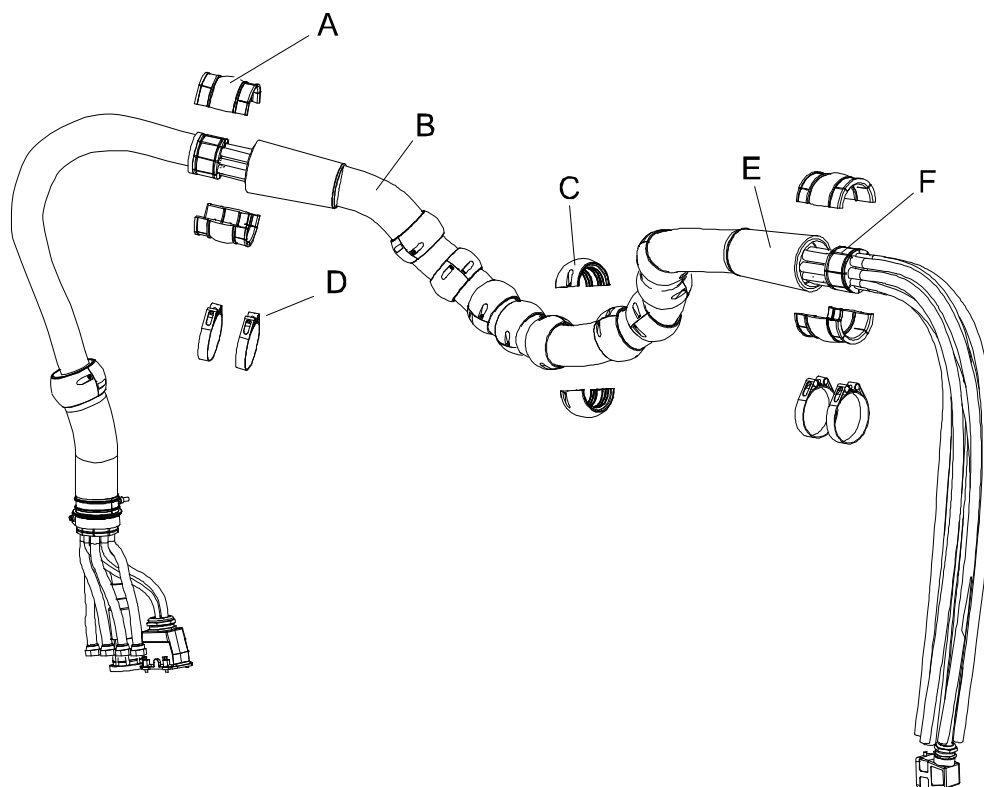

xx0500001549

A	Sliding sleeve
B	Protective hose
C	Protective sleeve
D	Hose clamp
E	Hose reinforcement
F	Hose and cable retainer
G	Cable star
H	Clamp jaw

Continues on next page

7 Spare parts

7.2.4 DressPack for Upper arm MH - IRBDP MH2 UE

Continued

Upper arm cable package IRBDP MH2

Qty	Parts	Article number	Note
1	Process Cable Package Upper arm MH, CPS/Ethernet, 1 hose	3HAC038553-001	IRB 6650S-200/3.0 IRB 6650S-190/3.0 LID Paracom + Ethernet
1	Process Cable Package Upper arm MH, CPS/Ethernet, 1 hose	3HAC023252-001	IRB 6650S-200/3.0 IRB 6650S-190/3.0 LID Paracom + Ethernet
1	Process Cable Package Upper arm MH, CPS/Ethernet, 1 hose	3HAC038553-002	IRB 6650S-125/3.5 IRB 6650S-100/3.5 LID Paracom + Ethernet
1	Process Cable Package Upper arm MH, CPS/Ethernet, 1 hose	3HAC023252-002	IRB 6650S-125/3.5 IRB 6650S-100/3.5 LID Paracom + Ethernet
1	Process Cable Package Upper arm MH, CPS/CBUS 1hose	3HAC023253-001	IRB 6650S-200/3.0 IRB 6650S-190/3.0 LID Parabuscom
1	Process Cable Package Upper arm MH, CPS/CBUS 1hose	3HAC023253-002	IRB 6650S-125/3.5 IRB 6650S-100/3.5 LID Parabuscom
1	Material Set	3HAC022484-001	IRB 6650S
2	Hose reinforce protection (UL, UR)	3HAC17221-1	

Spare parts for cable package

Qty	Spare part	Article number	Note
3m	Protection hose	3HAC5320-2	Wear part
11	Protective sleeve	3HAC021580-001	Wear part
2	Hose reinforcement	3HAC022194-001	Wear part
1	Hose clamp Diam=79 mm	3HAC5325-3	
4	Hose clamp Diam=94 mm	3HAC5325-2	
1	Clamp jaw	3HAC14590-1	
1	Cable star	3HAC023875-002	
4	Slide sleeve	3HAC16208-1	Wear part
2	Hose and cable retainer	3HAC14811-1	

Spare parts included in Material set upper arm

Qty	Spare part	Article number	Note
1	Tension arm unit	3HAC022307-001	
1	Damper (tension arm)	3HAC022307-048	Wear part
1	Process cable support axis 6, complete	3HAC025495-003	

Continues on next page

Qty	Spare part	Article number	Note
1	Gripping clamp	3HAC14280-1	
1	Plate	3HAC022307-041	

7 Spare parts

7.2.5 DressPack upper arm MH - IRBDP MH3 UE

7.2.5 DressPack upper arm MH - IRBDP MH3 UE

General

The following section describes spare parts for DressPack upper arm cable package.

DressPack upper arm MH3

Parts	Art.no.	Note
Process cable package upper arm MH 3, CPS	3HAC026813-001	Paracom
Process cable package upper arm MH 3, CPS/CBUS	3HAC026813-002	Parabuscom
Ethernet cable	3HAC034204-002	Ethernet
Material set upper arm MH 3	3HAC024692-001	All variants
Material set upper arm MH 3 ¹⁾	3HAC024692-049	IRB 6650S-90/3.9 ¹⁾

1) The material set for IRB 6650S-90/3.9 art. no. 3HAC024692-049 is complementary to 3HAC024692-001. For this variant both material sets are needed.

Spare parts for cable package

Parts	Art.no.	Note
Protection hose	3HAC024692-060	Wear part
Hose upper arm MH3	3HAC024692-047	
Clamp half	3HAC024692-051	
Gripping clamp	3HAC024692-013	
Velcro strap	3HAC12625-1	
Protective sleeve, NW 52	3HAC032661-001	Wear part

7.2.6 DressPack for - IRBDP MH2 CE and IRBDP SW2 CE

General

The following section details spare parts for cable packages IRBDP MH2 CE and IRBDP SW2 CE.

Lower/Upper arm cable package

Part	Article number	Note
Process Cable Package lower/upper arm SW, CPS, 4 hoses	3HAC022486-001	IRB 6650S-200/3.0 IRB 6650S-190/3.0 LID Paracom
Process Cable Package lower/upper arm SW, CPS, 4 hoses	3HAC022486-002	IRB 6650S-125/3.5 IRB 6650S-100/3.5 LID Paracom
Process Cable Package Lower/Upper arm SW, CPS+SP 4 hoses	3HAC022487-001	IRB 6650S-200/3.0 IRB 6650S-190/3.0 LID Paracom Servo gun
Process Cable Package Lower/Upper arm SW, CPS+SP 4 hoses	3HAC022487-002	IRB 6650S-125/3.5 IRB 6650S-100/3.5 LID Paracom Servo gun
Process Cable Package Lower/Upper arm SW, CPS/CBUS 4 hoses	3HAC022488-001	IRB 6650S-200/3.0 IRB 6650S-190/3.0 LID Parabuscom
Process Cable Package Lower/Upper arm SW, CPS/CBUS 4 hoses	3HAC022488-002	IRB 6650S-125/3.5 IRB 6650S-100/3.5 LID Parabuscom
Process Cable Package Lower/Upper arm SW, CPS/CBUS+SP 4 hoses	3HAC022491-001	IRB 6650S-200/3.0 IRB 6650S-190/3.0 LID Parabuscom Servo gun
Process Cable Package Lower/Upper arm SW, CPS/CBUS+SP 4 hoses	3HAC022491-002	IRB 6650S-125/3.5 IRB 6650S-100/3.5 LID Parabuscom Servo gun

Continues on next page

7 Spare parts

7.2.6 DressPack for - IRBDP MH2 CE and IRBDP SW2 CE

Continued

Part	Article number	Note
Material Set lower arm	3HAC022483-001	IRB 6650S-200/3.0 IRB 6650S-190/3.0 LID IRB 6650S-125/3.5 IRB 6650S-100/3.5 LID
Material Set upper arm	3HAC022484-001	IRB 6650S-200/3.0 IRB 6650S-190/3.0 LID IRB 6650S-125/3.5 IRB 6650S-100/3.5 LID

Spare parts for cable package

Qty	Spare part	Article number	Note
	Protection hose	3HAC5320-2	Wear part 4 m
	Protective sleeve	3HAC021580-001	Wear part
	Hose reinforcement	3HAC022194-001	Wear part
	Hose reinforce protection (UL, UR)	3HAC17221-1	
4	Slide sleeve	3HAC16208-1	Wear part
2	Hose clamp Diam = 79-87	3HAC5325-3	
4	Hose clamp Diam = 94-102	3HAC5325-2	
	Clamp jaw	3HAC14590-1	
	End jaw	3HAC14512-1	
	Cable star	3HAC023875-001	
	Middle jaw	3HAC14290-1	
	Swivel	3HAC027389-001	
	Hose clamp and cable retainer	3HAC14811-12	
	Strap, velcro	3HAC12625-1	IRB 6650S
	Hose support	3HAC024102-090	
	Bracket, hose support	3HAC024102-049	

Spare Parts included in Material set Lower arm

Qty	Spare part	Article number	Note
2	Gripping clamp	3HAC14280-1	
1	Velcro strap	3HAC12625-1	
2	Strap (balancing cylinder)	3HAC024008-001	

Continues on next page

Spare Parts included in Material set Upper arm IRB 6650S

Qty	Spare part	Article number	Note
1	Tension arm unit	3HAC022307-001	
1	Ball joint housing	3HAC021601-001	
1	Damper (Tension arm unit)	3HAC022307-048	Wear part
1	Harness support axis 6 complete	3HAC025495-001	
1	Plate	3HAC022307-041	
1	Gripping clamp	3HAC14280-1	

7 Spare parts

7.2.7 DressPack Basic cable package - IRBDP SW 5 CE

7.2.7 DressPack Basic cable package - IRBDP SW 5 CE

Overview

The following section details spare parts for DressPack Basic cable package IRBDP SW 5 CE.

Wear parts of cable package

Parts	Article no.	Note
Protection hose	3HAC5320-2	Wear part
Hose reinforcement	3HAC022194-001	Wear part
Protective sleeve	3HAC021580-001	Wear part

Spare parts for cable package

Parts	Spare part no.	Note
CS cable, axes 2-6	3HAC029391-001	
Weld cable 25 mm ²	3HAC029392-001	
Servo Power, axes 2-6	3HAC029580-001	
Resolvercable,R2.FB7	3HAC030638-001	
Hose protection	3HAC031582-001	
Swivel complete	3HAC027389-001	
Hose clamp Diam=79-87	3HAC5325-3	
Slide sleeve	3HAC16208-1	
Hose clamp Diam=94-102	3HAC5325-2	
Hose & cable retainer 60	3HAC026156-003	
Plastic clamp	3HAC026549-005	
Strap, velcro	3HAC12625-1	
Strap	3HAC024008-001	
Gripping clamp	3HAC14280-1	
End jaw	3HAC14512-1	
Ball joint housing	3HAC021601-001	
Process cable support axis 6	3HAC025495-003	

7.2.8 DressPack cable package IRBDP SW6 LE LeanID

General

This chapter contains more specific article information. It is to be regarded as a complement to the slightly generic procedure information found in the Installation, Maintenance and Repair chapters.

The robot system itself, consisting of robot and controller cabinet, is described in its own technical documents.

Spare parts

IRBDP SW6 LE

Spare part number	200/3.0 190/3.0 LID	125/3.5 100/3.5 LID	90/3.9
3HAC046476-001 Paracom	x	x	x
3HAC046476-002 Paracom Servo gun	x	x	x
3HAC046477-001 Parabus com	x	x	x
3HAC046477-002 Parabus com Servo gun	x	x	x
3HAC071387-001 Paramulti	x	x	x
3HAC071387-002 Paramulti Servo gun	x	x	x

7 Spare parts

7.2.9 DressPack cable package IRBDP MH3 LI

7.2.9 DressPack cable package IRBDP MH3 LI

General

This chapter contains more specific article information. It is to be regarded as a complement to the slightly generic procedure information found in the Installation, Maintenance and Repair chapters.

The robot system itself, consisting of robot and controller cabinet, is described in its own technical documents.

Spare parts

IRBDP MH3 LI

Spare part number	200/3.0 190/3.0 LID	125/3.5 100/3.5 LID	90/3.9
3HAC053922-001 Paracom	x	x	x
3HAC053923-001 Parabus com	x	x	x
3HAC071491-001 Paramulti	x	x	x

7.2.10 DressPack cable package IRBDP SW6 UI LeanID

General

This chapter contains more specific article information. It is to be regarded as a complement to the slightly generic procedure information found in the Installation, Maintenance and Repair chapters.

The robot system itself, consisting of robot and controller cabinet, is described in its own technical documents.

Spare parts

IRBDP SW6 UI

Spare part number	200/3.0 190/3.0 LID	125/3.5 100/3.5 LID	90/3.9
3HAC046482-001 Paracom	x		
3HAC046482-002 Paracom Long		x	
3HAC046482-003 Paracom Servo gun	x		
3HAC046482-004 Paracom Servo gun Long		x	
3HAC046483-001 Parabus com	x		
3HAC046483-002 Parabus com Long		x	
3HAC046483-003 Parabus com Servo gun	x		
3HAC046483-004 Parabus com Servo gun Long		x	
3HAC071287-001 Paramulti	x		
3HAC071287-002 Paramulti Long		x	
3HAC071287-003 Paramulti Servo gun	x		
3HAC071287-004 Paramulti Servo gun Long		x	

7 Spare parts

7.2.11 DressPack cable package IRBDP MH6 UI LeanID

7.2.11 DressPack cable package IRBDP MH6 UI LeanID

General

This chapter contains more specific article information. It is to be regarded as a complement to the slightly generic procedure information found in the Installation, Maintenance and Repair chapters.

The robot system itself, consisting of robot and controller cabinet, is described in its own technical documents.

Spare parts

IRBDP MH6 UI

Spare part number	200/3.0	125/3.5	90/3.9
	190/3.0 LID	100/3.5 LID	
3HAC046550-001 Paracom	x		
3HAC046550-002 Paracom Long		x	
3HAC046551-001 Parabus com	x		
3HAC046551-002 Parabus com Long		x	
3HAC071288-001 Paramulti	x		
3HAC071288-002 Paramulti Long		x	

7.2.12 DressPack cable package IRBDP MH3 UI

General

This chapter contains more specific article information. It is to be regarded as a complement to the slightly generic procedure information found in the Installation, Maintenance and Repair chapters.

The robot system itself, consisting of robot and controller cabinet, is described in its own technical documents.

Spare parts

IRBDP MH3 UI

Spare part number	200/3.0 190/3.0 LID	125/3.5 100/3.5 LID	90/3.9
3HAC046861-001 Paracom	x		
3HAC046861-002 Paracom Long		x	x
3HAC046862-001 Parabus com	x		
3HAC046862-002 Parabus com Long		x	x
3HAC071386-001 Paramulti	x		
3HAC071386-002 Paramulti Long		x	x

7 Spare parts

7.2.13 Sub cables

7.2.13 Sub cables

Spare parts

Spare part	Spare part number	200/3.0 190/3.0 LID	125/3.5 100/3.5 LID	90/3.9
CPS axis 3-6	3HAC046528-001	x		
CPS axis 3-6 Long	3HAC035764-001		x	x
SP axis 3-6	3HAC046530-001	x		
SP axis 3-6 Long	3HAC035763-001		x	
FB axis 3-6	3HAC046531-001	x		
FB axis 3-6 Long	3HAC035762-001		x	
CBUS axis 3-6	3HAC046533-001	x		
CBUS axis 3-6 Long	3HAC035765-001		x	x
Ethernet, upper arm	3HAC034204-001	x		
Ethernet, upper arm Long	3HAC034204-002		x	x

7.2.14 Wear parts

Wear parts

Spare part	Spare part number	Note
Protection hose Lower arm (1400 mm, 900 mm)	3HAC5320-2	Only delivered in full meters.
Protection hose Upper arm, back end (500 mm)	3HAC042173-002	
Protection hose Upper arm, front end (1080 mm)	3HAC042173-003	Must be cut to the correct length before use.
Hose reinforcement funnel	3HAC032916-001	 xx1400001982
Protective sleeve, rotary	3HAC032660-001	 xx1400001981
Clamp insert	3HAC042483-001	 xx1400001400

Continues on next page

7 Spare parts

7.2.14 Wear parts

Continued

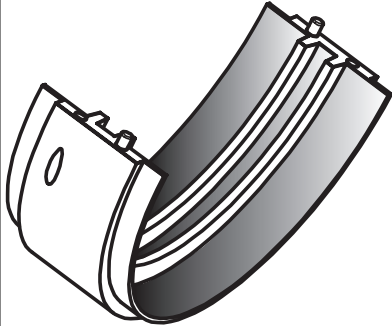
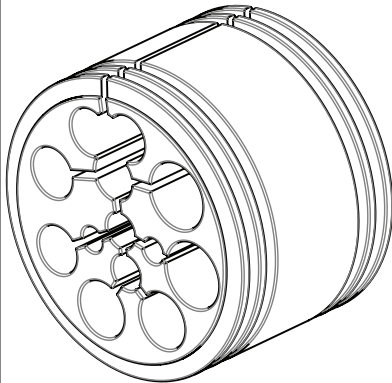
Spare part	Spare part number	Note
Middle jaw	3HAC14290-1	 xx1400001399
Cable & Hose Retainer 60	3HAC035251-001	 xx1400001398

7.2.15 Connection kits

General

This chapter contains more specific article information. It is to be regarded as a complement to the slightly generic procedure information found in the Installation, Maintenance and Repair chapters.

The robot itself and controller cabinet, is detailed in separate technical documents.

Connection kit - IRBDP SW, IRBDP SW2, IRBDP SW5, IRBDP MH1, IRBDP MH2

Spare part	Article number	Note
CP/CS, Proc. 1 ax.3	3HAC024577-001	
CP/CS, Proc. 1 on base	3HAC16667-1	
Weld, Proc. 1-4 on base	3HAC17201-1	
Weld, Proc. 2-4 ax. 3	3HAC17202-1	
Weld, Proc. 1-4 ax.6 (35 mm ²)	3HAC023072-001	
7-axis on base	3HAC023441-001	
CP/CS/CBUS, Proc. 1 ax. 6	3HAC020155-001	Tool side
CP/CS/CBUS, Proc. 1 ax. 6	3HAC029072-001	Tool side MH3

Connection kit - IRBDP MH3, IRBDP MH6 and IRBDP SW6 LeanID

Spare part	Article number	Note
Weld, Proc. ax.6	3HAC043502-001	
CP/CS/CBUS, Ether, Proc. ax. 6	3HAC043503-001	

7 Spare parts

7.2.16 7:th axis to base

7.2.16 7:th axis to base

General

This chapter contains more specific article information. It is to be regarded as a complement to the slightly generic procedure information found in the Installation, Maintenance and Repair chapters.

The robot itself and controller cabinet, is detailed in separate technical documents.

Spare parts

Part	Article number	Note
7:th axis, serial cable	3HAC023278-001	

7.2.17 Customer signal/power

General

This chapter contains more specific article information. It is to be regarded as a complement to the slightly generic procedure information found in the Installation, Maintenance and Repair chapters.

The robot itself, consisting of robot and controller cabinet, is detailed in its own technical documents.

Spare parts floor harness (3HAC023120-001, 3HAC023121-001)

Part	Article number	Note
Harness-CP/CS/DeviceNet, 7 m	3HAC022978-001	Parallel DeviceNet
Harness-CP/CS/DeviceNet, 15 m	3HAC022978-002	Parallel DeviceNet
Harness-CP/CS/DeviceNet, 22 m	3HAC022978-006	Parallel DeviceNet
Harness-CP/CS/DeviceNet, 30 m	3HAC022978-003	Parallel DeviceNet
Harness-CS floor cable, 7 m	3HAC029393-001	Parallel
Harness-CS floor cable, 15 m	3HAC029393-002	Parallel
Harness-CP floor cable, 7 m	3HAC029396-002	24V
Harness-CP floor cable, 15 m	3HAC029396-001	24V
Harness-CP/CS/InterBus, 7 m	3HAC023024-001	InterBus
Harness-CP/CS/InterBus, 15 m	3HAC023024-002	InterBus
Harness-CP/CS/InterBus, 22 m	3HAC023024-006	InterBus
Harness-CP/CS/InterBus, 30 m	3HAC023024-003	InterBus
Harness-CP/CS/Pbus, 7 m	3HAC022988-001	ProfiBus
Harness-CP/CS/Pbus, 15 m	3HAC022988-002	ProfiBus
Harness-CP/CS/Pbus, 22 m	3HAC022988-006	ProfiBus
Harness-CP/CS/Pbus, 30 m	3HAC022988-003	ProfiBus
Harness-CP/CS, 7 m	3HAC022957-001	Parallel
Harness-CP/CS, 15 m	3HAC022957-002	Parallel
Harness-CP/CS, 22 m	3HAC022957-006	Parallel
Harness-CP/CS, 30 m	3HAC022957-003	Parallel

7 Spare parts

7.3.1 DressPack - Water and air unit

7.3 DressPack - Water and air unit

7.3.1 DressPack - Water and air unit

Overview

The following section details spare parts for DressPack Water and air unit.

Water and air unit

Parts	Article no.	Note
Water and air unit	3HAC048636-001	Basic
Water and air unit	3HAC048636-002	2:nd water return
Water and air unit	3HAC048636-003	E/P valve

Hoses for Water and air unit

Parts	Article number	Note
Air hose if E/P valve	3HAC16845-2	Orange
Air hose if E/P valve	3HAC16845-4	Black
Hose water and air unit (3 pcs)	3HAC16845-1	Orange
Hose water and air unit (3 pcs)	3HAC16845-5	Black

7.4 Mechanical parts

Axis 3-4

Spare part	Article number	Note
Axis 3-4	3HAC056274-002-003	

This page is intentionally left blank

8 Circuit diagram

8.1 Circuit diagrams

Overview

The circuit diagrams are not included in this manual, but are available for registered users on myABB Business Portal, www.abb.com/myABB.

See the article numbers in the tables below.

Controllers

Product	Article numbers for circuit diagrams
<i>Circuit diagram - IRC5</i>	<i>3HAC024480-011</i>

DressPack

Product	Article numbers for circuit diagrams
<i>Circuit diagram - DressPack IRB 5710 / IRB 5720</i>	<i>3HAC081433-001</i>
<i>Circuit diagram - DressPack 6650S/7600 LeanID</i>	<i>3HAC022327-002</i>
<i>Circuit diagram - DressPack 6650S/7600</i>	<i>3HAC026209-001</i>
<i>Circuit diagram - DressPack 6620</i>	<i>3HAC026136-001</i>
<i>Circuit diagram - DressPack IRB 6640, IRB 6650S, IRB 7600</i>	<i>3HAC026209-001</i>
<i>Circuit diagram - DressPack 6660</i>	<i>3HAC029940-001</i>
<i>Circuit diagram - DressPack 6700</i>	<i>3HAC044246-002</i>
<i>Circuit diagram - DressPack IRB 6710 / IRB 6720 / IRB 6730 / IRB 6740</i>	<i>3HAC087933-001</i>
<i>Circuit diagram - DressPack 8700</i>	<i>3HAC053524-002</i>
<i>Circuit diagram - DressPack for spotwelding SWC IRC5 M2004</i>	<i>3HAC026208-001</i>
<i>Circuit diagram - DressPack SWC IRC5 Design 2014 PROFINET</i>	<i>3HAC044736-001</i>

Use the correct circuit diagram (IRB 6600, IRB 6650 and IRB 6650S)

The cable harness of the robot is available in two different designs. Either the cabling is divided between the upper and lower arm, or not. Accordingly there are also two different versions of the circuit diagram. Decide which circuit diagram is valid for the robot by checking the article number for the cable harness.

This page is intentionally left blank

Index

A

allergenic material, 27
aluminum
 disposal, 349
assessment of hazards and risks, 27

B

batteries
 disposal, 349

C

cabinet lock, 27
carbon dioxide extinguisher, 28
cast iron
 disposal, 349
climbing on robot, 30
copper
 disposal, 349

E

environmental information, 349

F

fire extinguishing, 28
functional ground, 229

G

grease, 30
grounding, 229

H

hanging
 installed hanging, 27
hazard levels, 19
hazardous material, 349
height
 installed at a height, 27
hot surfaces, 30
HRA, 27

I

integrator responsibility, 27

L

labels
 robot, 20
lifting accessory, 356
limitation of liability, 17
Lithium
 disposal, 349
lock and tag, 27
lubricants, 30

M

magnesium
 disposal, 349

N

national regulations, 27
neodymium
 disposal, 349
nodular iron

disposal, 349

O

oil, 30
original spare parts, 17

P

pedestal
 installed on pedestal, 27
personnel
 requirements, 18
plastic
 disposal, 349
PPE, 18
protective equipment, 18
protective wear, 18

R

recycling, 349
regional regulations, 27
replacements, report, 227
report replacements, 227
responsibility and validity, 17
risk of burns, 30
robot
 labels, 20
 symbols, 20
rubber
 disposal, 349

S

safety
 fire extinguishing, 28
 signals, 19
 signals in manual, 19
 symbols, 19
 symbols on robot, 20
 test run, 206
safety devices, 28
safety hazard
 hydraulic system, 28
 pneumatic system, 28
safety signals
 in manual, 19
screw joints, 353
signals
 safety, 19
steel
 disposal, 349
symbols
 safety, 19
system integrator requirements, 27

T

troubleshooting
 safety, 33

U

upcycling, 349
users
 requirements, 18

V

validity and responsibility, 17



ABB AB

Robotics & Discrete Automation

S-721 68 VÄSTERÅS, Sweden

Telephone +46 10-732 50 00

ABB AS

Robotics & Discrete Automation

Nordlysvegen 7, N-4340 BRYNE, Norway

Box 265, N-4349 BRYNE, Norway

Telephone: +47 22 87 2000

ABB Engineering (Shanghai) Ltd.

Robotics & Discrete Automation

No. 4528 Kangxin Highway

PuDong New District

SHANGHAI 201319, China

Telephone: +86 21 6105 6666

ABB Inc.

Robotics & Discrete Automation

1250 Brown Road

Auburn Hills, MI 48326

USA

Telephone: +1 248 391 9000

abb.com/robotics